

LEVEL MONITORING

for SMS (LBG)

51 Lund Avenue, Barnsley, S71 5NW

Client:	SMS (LBG)
Client Contact:	Ian Domigan
Claim Number:	102107974
Client Reference:	IFS-LBG-SUB-22-0100956
Policy Holder:	Mr and Mrs Brian and Janet Ivermee, 51 Lund Avenue, Barnsley, Yorkshire, S71 5NW
Report Date:	25 August 2025
Our Ref:	M18893

Level Monitoring Readings

The following table shows the reading levels of the various Level Monitoring Station points.

Date	1	2	3	4	5	6	7	8	9	10
21/07/2022	10.0000	10.0165	10.1149	10.0230	10.0009	10.0415	9.9879	9.9800	9.9722	9.9038
19/09/2022	10.0000	10.0145	10.1139	10.0223	10.0000	10.0397	9.9867	9.9793	9.9726	9.9035
25/11/2022	10.0000	10.0147	10.1141	10.0227	10.0006	10.0410	9.9872	9.9788	9.9730	9.9037
31/01/2023	10.0000	10.0150	10.1145	10.0240	10.0025	10.0429	9.9886	9.9811	9.9745	9.9056
20/03/2023	10.0000	10.0150	10.1149	10.0228	10.0006	10.0413	9.9873	9.9794	9.9732	9.9034
25/05/2023	10.0000	10.0146	10.1139	10.0223	10.0003	10.0407	9.9869	9.9787	9.9725	9.9034
19/07/2023	10.0000	10.0138	10.1139	10.0226	10.0000	10.0403	9.9870	9.9788	9.9729	9.9038
05/10/2023	10.0000	10.0144	10.1141	10.0228	9.9987	10.0401	9.9871	9.9790	9.9728	9.9036
01/12/2023	10.0000	10.0153	10.1153	10.0241	10.0014	10.0419	9.9882	9.9805	9.9750	9.9054
23/01/2024	10.0000	10.0159	10.1154	10.0240	10.0014	10.0423	9.9885	9.9804	9.9749	9.9055
22/03/2024	10.0000	10.0151	10.1142	10.0226	10.0007	10.0414	9.9876	9.9796	9.9739	9.9042
16/05/2024	10.0000	10.0143	10.1140	10.0232	10.0009	10.0420	9.9880	9.9799	9.9740	9.9051
16/07/2025	10.0000	10.0092	10.1147	10.0236	9.9927	10.0374	9.9863	9.9785	9.9731	9.9037
15/08/2025	10.0000	10.0052	10.1140	10.0231	9.9880	10.0359	9.9850	9.9775	9.9725	9.9029

Date	11	12	13	14
21/07/2022	10.0530	10.0462	9.9728	10.4044
19/09/2022	10.0519	10.0448	9.9711	10.4042
25/11/2022	10.0520	10.0450	9.9716	10.4042
31/01/2023	10.0534	10.0460	9.9736	10.4032
20/03/2023	10.0530	10.0458	9.9727	10.4045
25/05/2023	10.0523	10.0453	9.9727	10.4039
19/07/2023	10.0528	10.0456	9.9720	10.4035
05/10/2023	10.0529	10.0458	9.9717	10.4040
01/12/2023	10.0542	10.0472	9.9734	10.4043
23/01/2024	10.0540	10.0473	9.9744	10.4047
22/03/2024	10.0533	10.0464	9.9734	10.4042
16/05/2024	10.0542	10.0473	9.9756	10.4039
16/07/2025	10.0535	10.0469	9.9696	10.4045
15/08/2025	10.0529	10.0460	9.9671	10.4044

Level Monitoring Difference Graphs

The following graphs display the progressive movement that each Level Monitoring Station recorded at each separate site visit date to give an overall look at how much the property is moving.

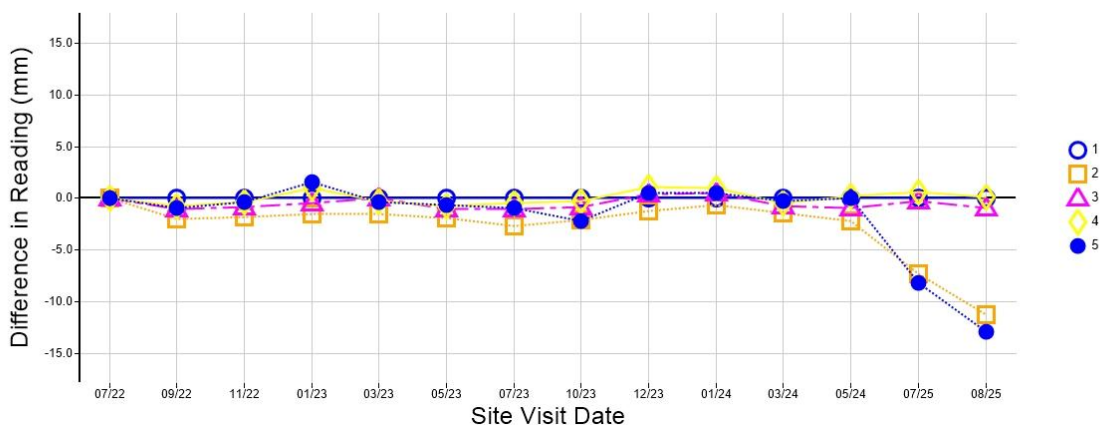

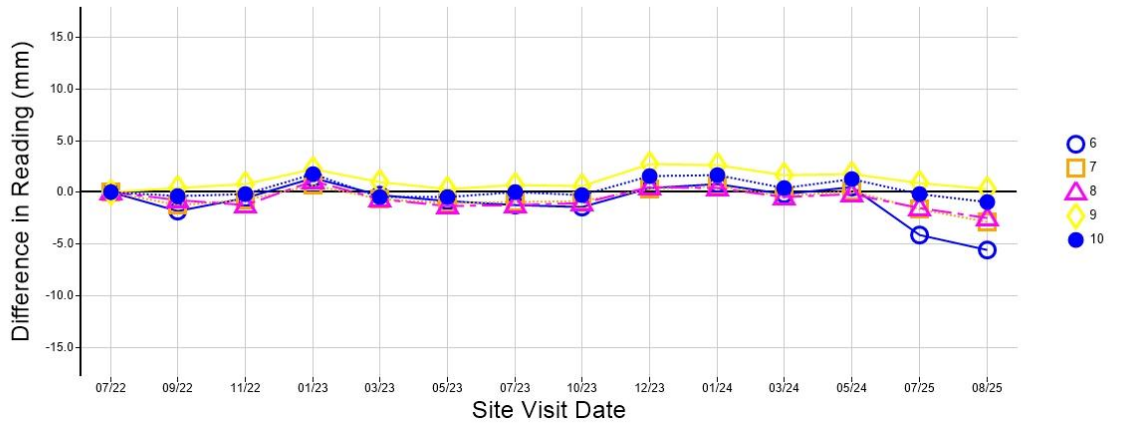

Level Monitoring Displacement Map

The following image shows an isometric representation of the movement of the property, based on the Level Monitoring Stations that were installed.

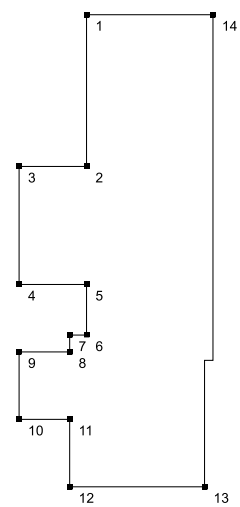
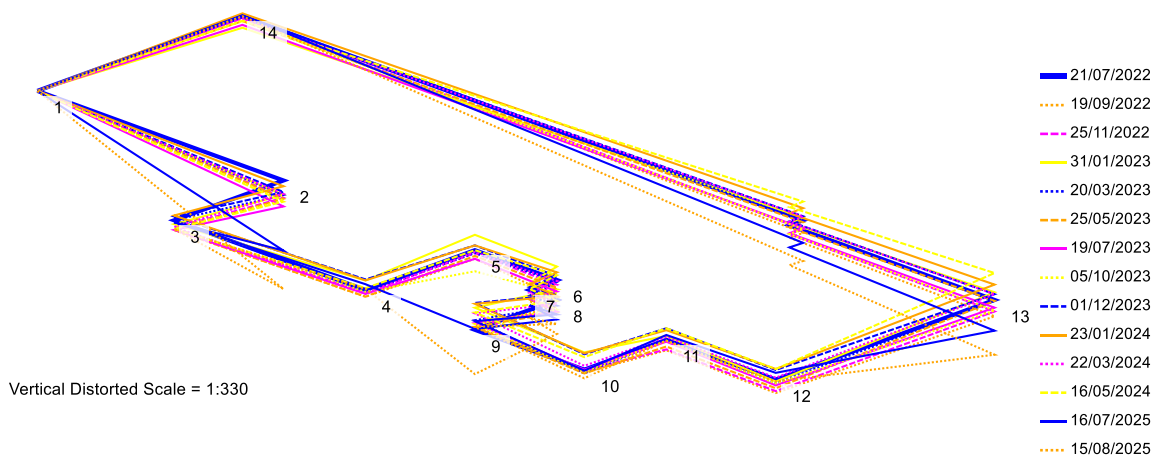

FRONT

Site Visit Notes

Datum is point 1 on the property. It has an assumed value of 10.0000m. Secondary TBM is a drain. If this is not suitable please advise if a deep datum is required.

Site Visit: 16 July 2025

PH is concerned that they have no monitoring points fixed to the rear of the property.

Site Visit: 15 August 2025

The PH has asked why the rear of the property is not been monitored as new cracks have appeared. please see email of pictures of new cracks.