



HORIZONTAL TWO BIKE LOCKER
Steel storage for 2no. bicycles

TECHNICAL SPECIFICATION

- 10 year warranty
- High security pick and drill resistant lock, includes the industry standard L&F mechanism with safety release - 3 point locking
- Reinforced handle enclosure
- UK engineered, designed and manufactured from polyester powder coated mild steel
- Weatherproofed, coated in a hard-wearing scratch/knock-resistant powder coating
- Maintenance friendly
- Concealed stainless steel, rust resistant fixings
- Ventilation system both front and back
- Single large door access
- Optional internal hanging hooks
- To be installed on a solid/level surface
- No base supplied with locker

PRODUCT DIMENSIONS

- Height : 1205mm
- Width : 855mm
- Depth : 1900mm
- Door clearance : 805mm
- Door space : H1115 x W755mm

TRIUMPH CERTIFICATIONS

- Quality : ISO 9001
- Environment : ISO 14001
- Health and safety : ISO 18001

STORAGE COLOUR OPTIONS



ACCESSORIES

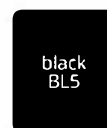

ENVIRONMENTAL FACTS

Eco Credentials

- Recyclability - 98%
- Returnable packaging - Yes

Secure Cycle Storage recyclability

98%

Business Investment



TECHNICAL DIMENSIONS

OVERALL DIMENSIONS

Height (H)	1205mm
Width (W)	855mm
Depth (D)	1900mm

Weight	115KG
--------	-------

Door Space	1115 x 755mm
------------	--------------

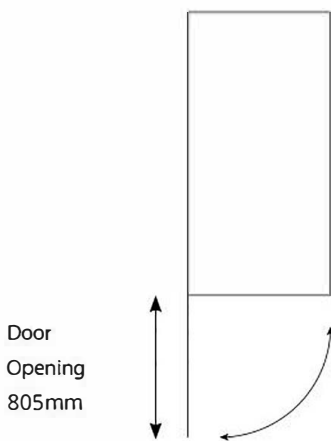

HEIGHT
1205mm

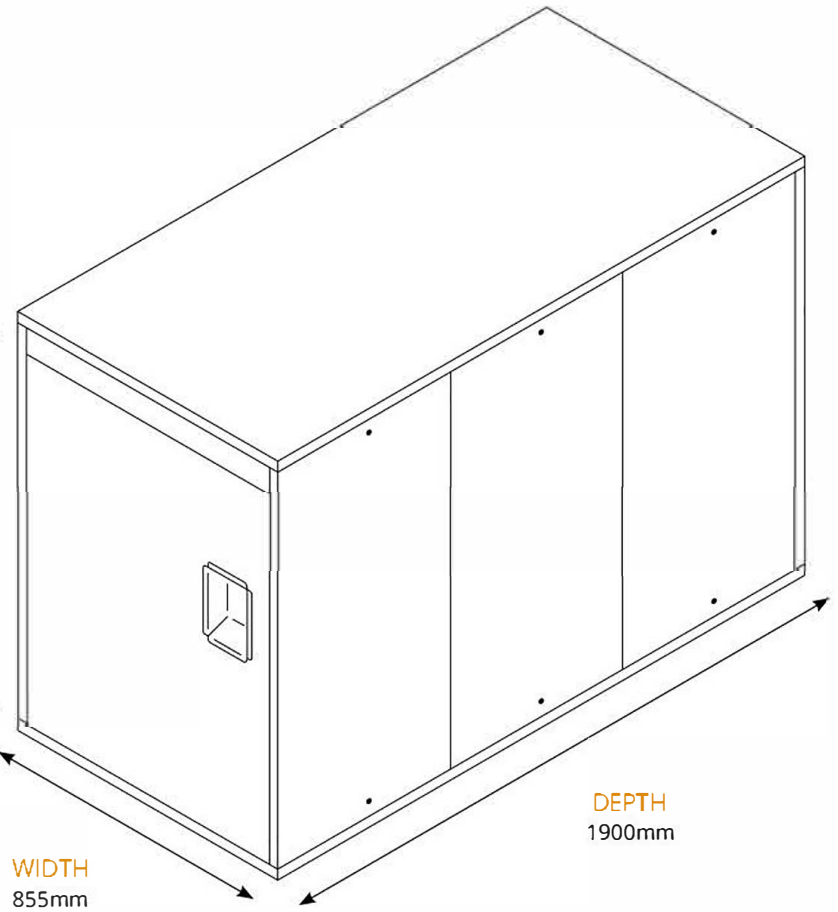

INTERNAL DIMENSIONS

Height (H)	1180mm
Width (W)	850mm
Depth (D)	1900mm

