

All NAL sockets are to be installed to the manufacturers detail. Socket type to be suitable for required post dimensions.

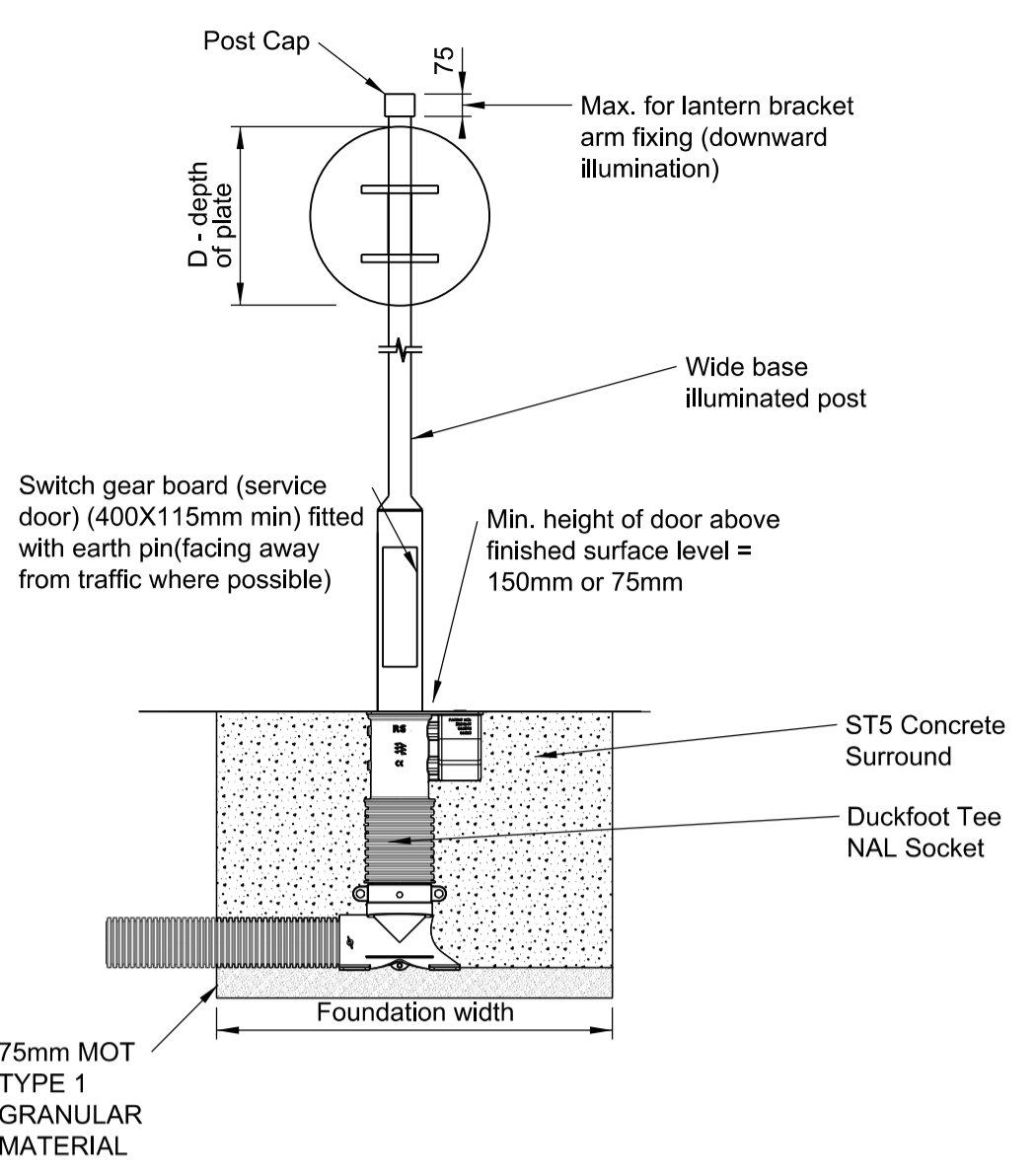

All NAL sockets are to be installed to the manufacturers detail. Socket type to be suitable for required post dimensions.

- Notes:**
- For Phase 1 signage refer to drawing A61-ARUP-XX-XX-DR-CH-111 and sign schedule A61-ARUP-XX-XX-RP-CH-0102.
 - For Phase 2 signage refer to drawing A61-ARUP-XX-XX-DR-CH-206 and sign schedule A61-ARUP-XX-XX-RP-CH-0202.

P02	24/11/21	SM	HJ	CW
Updated to refer to Phase 1 and 2				
P01	08/10/21	KK	HJ	CW
Stage 4 Issue				

ARUP

Admiral House, Rose Wharf,
78 East Street, Leeds, LS9 8EE
Tel +44(0)113 242 8498 Fax +44(0)113 242 8573
www.arup.com

Client
South Yorkshire Passenger Transport Executive

Project Title
A61 Corridor

Drawing Title
Standard Details Sheet 3

Scale at A1	As shown
Role	Civil - General
Suitability	S1 - Fit for co-ordination
Arup Job No	Rev
253511-00	P02
Name	
A61-ARUP-XX-XX-DR-CH-142	