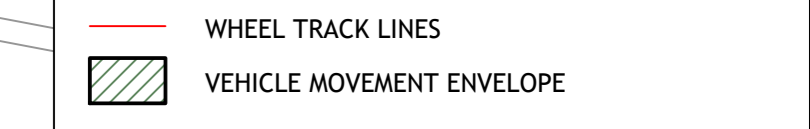
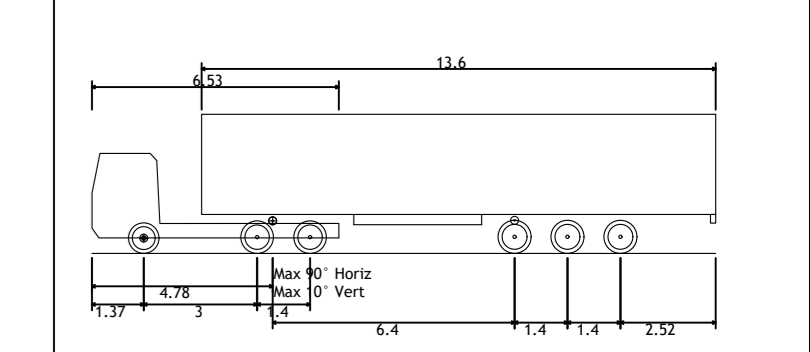

DO NOT SCALE
NOTES

GENERAL NOTES
 1. THE TOPOGRAPHICAL SURVEY IS BASED ON INFORMATION PRODUCED BY HAYCOCK & TODD, JOB NO. 5947, FILE 5947-10 BARNLEY WEST, DWS DATED MAY 2019. THE INFORMATION USED IN PREPARATION OF THIS AND ALL OTHER ENGINEERING DESIGN AND DRAWING IS NOT WARRANTED TO BE TRUE. THE CONTRACTOR SHALL BE RESPONSIBLE FOR VERIFYING ALL SURVEY INFORMATION PROVIDED AND REPORT ANY ANOMALIES TO FORE CONSULTING.

DESIGN NOTES
 1. ALL DESIGN AND WORKS TO COMPLY WITH CURRENT VERSION OF THE FOLLOWING DOCUMENTS:
 - DESIGN MANUAL FOR ROADS AND BRIDGES (DMRB);
 - SPECIFICATION FOR HIGHWAY WORKS (SHW);
 - MANUAL FOR STREETS AND
 - BARNLEY METROPOLITAN BOROUGH COUNCIL (BMBC) DESIGN GUIDE AND SPECIFICATION.
 2. SWEEP PATH ANALYSIS PERFORMED USING AUTODESK VEHICLE TRACKING 2016 SOFTWARE.

KEY

 - WHEEL TRACK LINES
 - VEHICLE MOVEMENT ENVELOPE



Max Legal Length (UK Articulated Vehicle) 16.50m
 Overall Length 2.550m
 Overall Width 2.681m
 Min Body Ground Clearance 0.411m
 Max Track Width 2.250m
 Lock-to-lock time 6.00s
 Curb to Curb Turning Radius 6.530m



REV	DESCRIPTION	DATE	BY

Client:
STRATA STERLING BARNLEY WEST LTD

Project:
**BARNLEY WEST
 BARUGH GREEN ROAD ROUNDABOUT**

Drawing Title:
SWEEP PATCH ANALYSIS

FOR COMMENT

Fore Consulting Limited
 2nd Floor, Queens House
 24 Wellington Street
 Leeds
 LS1 2SE
 0113 2660204
 enquiries@foreconsulting.co.uk
 www.foreconsulting.co.uk

Rev No	Rev Description	Date	By
01	PI	18.10.2019	1:500
9014	A1-100-SK-102		A0