

**DO NOT SCALE**

**NOTES**

**GENERAL NOTES**

1. THE TOPOGRAPHICAL SURVEY IS BASED ON INFORMATION PRODUCED BY HAYCOCK & TODD, JOB NO. 25471, FILE 2617-10 BARNLEY WEST DWG DATED MAY 2019. THE INFORMATION USED IN PREPARATION OF THIS AND ALL OTHER WORKS CONSULTING DESIGN AND DRAWING IS NOT WARRANTED TO BE THE RESPONSIBILITY OF THE CONTRACTOR TO VERIFY ALL SURVEY INFORMATION PROVIDED AND REPORT ANY ANOMALIES TO FORE CONSULTING.

**DESIGN NOTES**

- ALL DESIGN AND WORKS TO COMPLY WITH CURRENT VERSION OF THE FOLLOWING DOCUMENTS:
  - DESIGN MANUAL FOR ROADS AND BRIDGES (DMRB);
  - SPECIFICATION FOR HIGHWAY WORKS (SHW);
  - MANUAL FOR STREETS AND
  - BARNLEY METROPOLITAN BOROUGH COUNCIL (BMBC) DESIGN GUIDE AND SPECIFICATION.
- SWEEP PATH ANALYSIS PERFORMED USING AUTODESK VEHICLE TRACKING 2016 SOFTWARE.

**KEY**

- WHEEL TRACK LINES
- VEHICLE MOVEMENT ENVELOPE

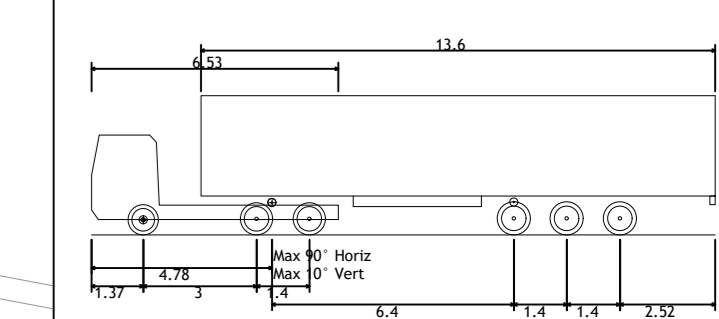

Max Legal Length (UK) Articulated Vehicle (16.5m)  
 Overall Length 16.500m  
 Overall Width 2.550m  
 Overall Body Height 3.681m  
 Min Body Ground Clearance 0.411m  
 Max Track Width 2.550m  
 Lock to lock time 6.95s  
 Kerb to Kerb Turning Radius 6.530m



F	CHANGES FOLLOWING COMMENTS	22.03.21	ML
E	DRAWING UPDATED TO MATCH 3D MODEL	30.11.20	ML
D	CHANGES FOLLOWING COMMENTS	22.09.20	ML
C	VEHICLE MOVEMENTS TRACKED WITH DYNAMIC EFFECT SETTING	22.09.20	ML
B	CHANGES FOLLOWING COMMENTS	19.08.20	ML
A	CHANGES FOLLOWING COMMENTS	14.07.20	ML
REV	DESCRIPTION	DATE	BY

Client:  
**STRATA STERLING BARNLEY WEST LTD**

Project:  
**BARNLEY WEST  
 BARNUGH GREEN ROAD ROUNDABOUT**

Drawing Title:  
**SWEEP PATH ANALYSIS  
 SHEET 1 OF 2**

**PRELIMINARY**

Fore Consulting Limited  
 2nd Floor, Queens House  
 14 Wellington Street  
 Leeds  
 LS1 2DE  
 0113 2460204  
 enquiries@foreconsulting.co.uk  
 www.foreconsulting.co.uk

Drawn by	PI	Checked by	ML	Date	21.02.2020	Scale	1:500	Format	A0
Sheet Number	9014	Drawing Number	A1-100-P-006	Revision	F				