

**Arboricultural Impact Assessment  
Mount Vernon Hospital, Barnsley**

Report reference: AR-3716-01.02  
September 2019  
Revised December 2019

---

Report Title:	Arboricultural Impact Assessment Mount Vernon Hospital
Report Reference:	AR-3716-01.02
Written by	Laura Buckley BA(Hons) DipLA MSc TechArborA Senior Arboricultural Consultant
Technical review:	Victoria Black FdSc Arb Principal Arboricultural Consultant
Approved for issue	Victoria Black FdSc Arb Principal Arboricultural Consultant
Date	06.09.19 Revised December 2019

---



Unit A, 1 Station Road, Guiseley, Leeds, LS20 8BX  
Phone: **01943 884451**  
**01943 879129**  
Email: [admin@brooks-ecological.co.uk](mailto:admin@brooks-ecological.co.uk)  
[www.brooks-ecological.co.uk](http://www.brooks-ecological.co.uk)  
Registered in England Number 5351418





## Contents

Contents	2
Summary statement	2
Introduction	3
Impact schedule	3
Implications for retained trees	4
Photographs	8
Tree Protection Plan DR-3716-01.01	11
Original Tree Surveys carried out by Altofts Tree Services	12

## Summary Statement

The Site contains the redundant Mount Vernon Hospital in Worsbrough, Barnsley. The Site currently comprises several disused buildings, paved access roads, grassland and peripheral trees. To the north and south are residential properties while to the east runs Mount Vernon Road. The topography is complex. The development proposal is for 65 residential plots.

The Site visit on 6<sup>th</sup> August 2019 found nine trees and one tree group remaining for nesting birds, following some earlier nesting bird surveys and climbed endoscope inspections. A belt of woodland trees is located along the south-west side of the Site on steeply sloping ground.

Eight of the individual trees are proposed for removal. The woodland belt and remaining tree and tree group to be retained should be protected from damage during the construction works with tree barrier fencing.

This report should be read in conjunction with the attached Tree Protection Plan Ref: DR-3716-01.01.



## Introduction

### *Purpose of the report*

1. This report has been commissioned by Orion Homes to provide professional independent, detailed arboricultural advice on relevant trees present at land to the Mount Vernon Hospital Site in Barnsley.
2. A development layout plan has been provided by Orion Homes, drawing number SK001, revision O, dated 10.07.19. Two Tree Survey reports by Altofts Tree Services in October 2017 and revised in April 2019 were provided for reference, though these reports did not include retention categories. It should be noted that the tree positions on DR-3716-01.01 Tree Protection Plan are estimates only.

## Impact Schedule

The following schedule identifies the individual tree and its retention category with the main feature(s) of the proposed works likely to cause an impact. The tree references are shown on the tree constraints plan and the tree protection plan. Any mitigation measures are noted.

Tree ref.	Species	Retention category	Proposal feature	Impact	Mitigation
<b>1924</b>	Swedish whitebeam	Not provided	Uplift of road paving. Rear gardens of plots 4, 5 and 6.	Possible root damage.	Paving remains in situ during the construction then removed with the use of hand tools only. Tree protection barrier to BS5837:2012 around RPA. Care during construction to avoid root damage.
<b>Group G6</b>	Holly Lawson's cypress Ash	Not provided	Uplift of road paving. Rear gardens of plots 6, 7, 8 and 9.	Possible root damage.	Paving remains in situ during the construction then removed with the use of hand tools only. Tree protection barrier to BS5837:2012 around RPA. Care during construction to avoid root damage.
<b>T10</b>	Elm	Dying	Rear gardens – health and safety risk – remove.	N/A	N/A
<b>T11</b>	Elm	Dead	Rear gardens – health and safety risk – remove.	N/A	N/A
<b>Woodland</b>	Beech Sycamore Ash	“	Removal of hard standing and existing buildings. Demolition of existing buildings Rear gardens of plots 23 to 32.	Possible root damage during construction. Crown lifting to 2m may be required. Crown reduction adjacent existing buildings required.	Paving remains in situ during the construction then removed with the use of hand tools only. Buildings should be collapsed onto their existing footprints and in a direction away from any retained trees to prevent any damage occurring. This method is called 'top down, pull back'. Tree protection barrier to BS5837:2012 around RPA. Care



Tree ref.	Species	Retention category	Proposal feature	Impact	Mitigation
					during construction to avoid root damage.

## Implications for retained trees

### *Tree protection*

3. Trees and tree groups to be retained within the development should be protected from unwanted damage during construction works with temporary tree protection barriers. The barriers should be erected to the outer edge of the tree canopy or the edge of the RPA, whichever is the furthest away from the tree, unless otherwise indicated on the Tree Protection Plan.
4. Tree protection barriers should be the default specification for protective barrier, Figure 1 below (following BS 5837: 2012 Trees in relation to design, demolition and constructions – Recommendations). Where Site circumstances prevent the use of the default barrier, an alternative specification would be recommended by the project arboriculturist with agreement of the local planning authority. It was noted on Site that there is an existing length of palisade fencing in the south east corner of the Site separating the woodland belt from a car park area in the lower part adjacent Mount Vernon Road. With approval from the local planning authority, it is recommended that this fencing be retained in place to act as a tree barrier during the works and possibly post-construction, depending upon the proposed location of the rear garden fencing line for plots 10, 11 and 12.
5. The top of the steep slope along the woodland belt is recommended as a location for extending the tree protection fencing along the belt.
6. All-weather notices should be attached to the barrier with words such as: "Construction exclusion zone – no access".

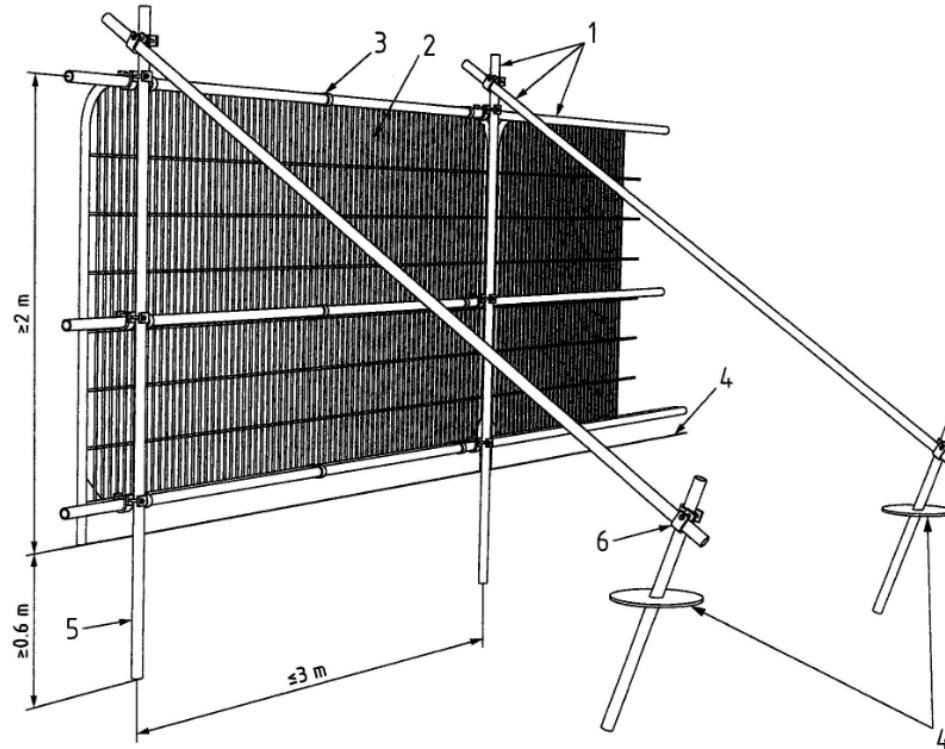

**Key**

- 1 Standard scaffold poles
- 2 Heavy gauge 2 m tall galvanized tube and welded mesh infill panels
- 3 Panels secured to uprights and cross-members with wire ties
- 4 Ground level
- 5 Uprights driven into the ground until secure (minimum depth 0.6 m)
- 6 Standard scaffold clamps

### Figure 1

#### *Tree work*

7. Where pruning work is necessary and authorised to roots or branches of retained trees to enable facilitation works, it should be carried out by a competent contractor in accordance with BS 3998: 2010 Tree Works – Recommendations.
8. Sections of the woodland slightly overhang the existing buildings. In these locations a crown lifting to 2m and a crown reduction will be required.
9. Roots smaller than 25mm diameter may be pruned back where necessary, making a clean cut with a suitable sharp tool, except where they occur in clumps. Roots in clumps or larger than 25mm diameter should be severed only following consultation with an Arboriculturist, as such roots may be essential to the health and stability of the tree.

#### *Demolition*

10. Demolition is expected within the proposed Site works adjacent to the trees to be retained on the east side of the Site and beside the woodland belt, where buildings, many of which are temporary buildings, are dismantled. These buildings should be collapsed onto their existing footprints and in a direction away from any retained trees to prevent any damage occurring. This method is called 'top down, pull back'.
11. It is recommended that tree protection fencing is erected to protect these trees from damage during the demolition works.
12. Where existing road paving is uplifted for the plots affecting tree 1924, Group 6 and the woodland, it is recommended that the paving remains in situ during the construction works to provide some ground protection for the root protection areas, then removed with the use hand tools only.
13. All demolition works within RPA's should supervised by Brooks Ecological.
14. Regular brief reports, including photos, should be submitted to Barnsley Council's tree officer.



15. All tree protective fencing should remain intact until ALL works are completed.

*Drainage and utilities*

16. Drainage and utilities are expected to be included within the proposed Site works and should not involve digging or trenching within RPA's.

## Photographs



Photograph 1

The lower, south-east corner of the Site where a section of palisade fencing stands between the woodland belt and the car parking area (discernible on the left side of image above the bramble). This fencing could be utilised as a tree barrier protecting the woodland, subject to the location of proposed garden fencing.



Photograph 2

Looking south-east along the edge of one of the disused hospital buildings on the left and the top of the steep slope with the woodland belt to the right. The tree protection barrier is recommended at the top of this slope, approximately where the railings are now in the centre of the image.



Photograph 3

Looking north-west along the edge of one of the disused hospital buildings on the right and the top of the steep slope with the woodland belt to the left. The tree protection barrier is recommended at the top of this slope, approximately where the railings are now in the centre of the image.



Photograph 4

Looking north-east along the Mount Vernon Road side of the Site to tree 1924 Swedish whitebeam (left hand side) and group G6 are expected to be retained within the development.



Photograph 5

Looking north to small trees Cotoneaster 1961 and holly 1990 which have been removed for the development after the bird nesting season 2019.



**NOTES**

This plan should be read in colour.

The tree/group positions are estimated from observations on site.

The line of the tree protection barrier is estimated and confirmation of required location should be ascertained on site.

KEY	
Tree to be retained	
Estimated Root Protection Area (RPA)	
Tree protection barrier	

Mount Vernon Hospital, Worsbrough, Barnsley

Tree Protection Plan

Dwg. No. DR-3716-01-01

Scale: 1:500 @ A1 Date: Sep. 2019

**Brooks Ecological**  
 Grounded advice

Brooks Ecological Ltd 01943 884451  
 Unit A, 1 Station Road, Guiseley, Leeds, LS20 8BX



## Tree Protection Plan DR-3716-01.01

A photograph of a forest path with sunlight filtering through the trees. The path is covered in fallen leaves and leads into a dense forest of tall, thin trees. The sunlight creates a dappled effect on the ground and foliage.

# **ALTOFTS TREE SERVICES**

**Arboricultural Survey  
Mount Vernon Hospital  
Mount Vernon Road  
Barnsley**

**Prepared for:  
Orion Homes  
5 Benton Office Park  
Bennett Avenue  
Horbury**

**Prepared by:  
Katherine Stephenson Tech Cert (Arb.A.)**

**Ash Tree Lodge, Snaith Road  
Pollington, East Yorkshire, DN14 0AT  
01405 861330  
altofts@btconnect.com**

## Table of Contents

- 1) Introduction
- 2) Site Description
- 3) Observations
- 4) Arboricultural Implications Assessment
- 5) Tree Protection Plan
- 6) Development Phase
- 7) Development Near Trees
- 8) Services
- 9) Removal of Protective Fencing
- 10) Completion Meeting
- 11) Conclusion
- 12) Useful Names and Numbers
- 13) Key to Spreadsheets
- 14) Survey Spreadsheets
- 15) Root Protection Area (RPA) Spreadsheet

## **1. Introduction**

1.1 This report is to be read as an integral part of a formal planning application submission to the relevant planning authority

1.2 Instructions were received from Orion Homes to undertake and amend an arboricultural survey in accordance with BS5837:2012 in relation to the redevelopment of land at Mount Vernon site, Barnsley

1.3 The survey original was undertaken by Katherine Stephenson in October 2017. Weather conditions were dry, but overcast. Relevant diameters at 1.5m were recorded by Orion Homes representative in April 2019

1.4 All the trees were inspected from ground level and all recommendations are issued on this basis.

1.5 In most cases the trees have been identified with numbered tags left from previous surveying and used currently for ease of reference – See plan in Original survey dated Oct 17

## **2. Site description**

Mount Vernon was previously owned by the NHS

The majority of the trees growing within what was the ground of the hospital have now been removed in preparation for redevelopment.

The woodland belt running along the south west boundary has an approximate north to south downward sloping orientation, which is quite steep in areas. The woodland has been left to develop naturally which creates good habitat, but not necessarily the most aesthetically attractive area. Due to the sloping land this area is impractical to utilise, but does create a green visual barrier for the residential dwelling situated along that boundary.

If the woodland is being retained as a natural feature, little work is needed in the central areas, as lying and standing dead wood are vital components of any healthy woodland ecosystem. Care should be given to the vegetation on the edges where they may influence third party property and developable land.

## **3 Observations**

### **3.1 Dismantle, fell and remove for health and safety reasons:**

T3: Sycamore

T11: Dead Ivy covered tree

WT6: Sycamore

### **3.2 Dismantle, fell and remove as part of redevelopment or causing obstruction for the future:**

1961: Cotoneaster

1990: Holly

1971: Cypress

T3: Sycamore  
T11: dead tree  
1971: Cypress  
1995: Whitebeam

### 3.3 Remedial pruning works are listed in supporting tables

## **4 Arboricultural Implications Assessment**

4.1 Majority of the site clearance has already been carried out. A number of trees have been left due to nesting birds and will be removed at the end of this nesting season.

4.2 The wooded area shall be retained, hopefully meaning the development to main site will have minimal, long term impact to the local wildlife. Repetitive tree species have established to maturity in the locale to enhance continuity of habitat and character of the area.

4.7 Retained Trees:

<b>Species</b>	<b>Current Height</b>	<b>Ultimate Height (In ideal growing conditions)</b>
Ash	13m	35m
Rowan	3m	18m
Sycamore	13m	35m
Oak	13m	26m
Holly	8m	20m
Lawsons Cypress	5m	35m

Ultimate heights will not be achieved by these trees due to competition for light and space as well as restricted root space along the frontage, adjacent to Mount Vernon Road.

## **5 Tree Protection Plan**

5.1 Before any machinery is allowed on site or any development works are started all approved tree work should be completed and all the trees to be retained should be fenced off.

5.2 The distances of the protective fencing from the trees should be ascertained from Section 15 (RPAs) of this survey: Root Protection Area (RPA) Spreadsheet

5.3 BS5837 recommends that the fencing should be constructed with a framework of scaffolding poles driven into the ground and braced together. Onto this, weldmesh panels should be securely fixed with wire or scaffold clamps.

5.4 If access is allowed within the root protection area a combination of ground protection and barriers should be erected.

a: for pedestrian access only, a single thickness of scaffold boards placed on top of a driven scaffold frame, giving a suspended walk way or on top of a compression resistant layer (e.g. 100mm depth of woodchip), laid onto a geotextile membrane.

- b. For pedestrian operated plant to a gross weight of 2t, proprietary, interlinked ground protection boards placed on top of a compression resistant layer (e.g. 150mm depth of woodchip), laid onto a geotextile membrane.
- c. For wheeled or tracked construction traffic exceeding 2t gross weight, an alternative system (e.g. proprietary system or precast reinforced concrete slabs) to an engineering specification designed in conjunction with arboricultural advice, to accommodate the likely loading to which it will be subjected.

## **6 Development Phase**

- 6.1 Storage areas may need to be moved as the site develops. Contractor's facilities and vehicles will also be relocated as the site develops. These should not be located within the RPA's of any retained trees.
- 6.2 At no point should any equipment or materials be stored in or near exposed tree protection zones. Any chemicals/ material should be stored on a non-permeable surface, preferable a bunded-type construction to allow easy control of any harmful spillage/ leaching.
- 6.3 No tree should be used as an anchor point for any winching activity.
- 6.4 No fire should be lit within 10m of a trees crown.
- 6.5 The local authority's arboriculturalist shall have free access to the site and report any problem areas to the developer and their arboriculturalist. Recommendations can then be made to the developer on how best to rectify the situation.
- 6.6 If dismantling structures or hard-standing, extreme care should be taken in order that the trees are not damaged.
- 6.7 Any hardscape being removed affecting nearby root systems from the retained trees should be demolished systematically away from the trees. It may be broken by machinery, but then must be lifted and removed by hand. A hydro-excavator or air-spade can be used to remove soil around root system.

## **7. Development near Trees**

- 7.1 No roots are to be severed and any that are exposed should be immediately covered by a minimum of 10cm of sharp sand with a geo-textile membrane on top, this avoids desiccation and contamination.
- 7.2 Any work exposing roots should be carried out immediately and completed as soon as possible, ideally within a single working day to avoid damaging the trees.
- 7.4 Dismantling of any part of a retaining wall should be completed by hand and supported by close boarding and props or anchor pins. Any root exposed should be covered as above.



## 13 Key To Spreadsheets

TAG No.: Identification number on tags to be found on the surveyed trees. G at the beginning of a tag no. denotes a group of trees. T denotes a single tree that for whatever reason is unable to be tagged. H denotes a hedge. A denotes an area.

SPECIES: Common Name

HEIGHT (M): Height estimated in metres.

DIAMETER @ 1.5 (MM): Diameter of main stem at 1.5 metres above ground level. M/S - Multi-stemmed.

VIGOUR: L = Low, N = Normal

BS5837 CAT.: Refers to BS5837: 2012

A = Trees whose retention is most desirable. High category

B = Trees where retention is desirable. Moderate category

C = Trees which could be retained. Low category

R = Trees for removal on health grounds for safety



Tag/Ref No.	Species	Observations	Recommendations	Safety Priority	Vigour	Diam. @ 1.5m (mm)	BS5837 Cat.
G9	3x Rowan	Healthy, establishing trees	No work necessary	LOW	N	206 200 150	B2
<b>T11</b>	<b>Dead tree</b>	<b>Heavily ivy covered, in fact ivy probably helping to keep tree standing and branches intact. Overhanging highway and junction</b>	<b>Fell and remove</b>  Remove to facilitate redevelopment once nesting bird season has finished	<b>HIGH</b>	<b>L</b>	-	<b>R</b>
1995	Whitebeam	Branch stubs remain from quick pruning. Ivy growing on stem. Nesting birds present	Remove to facilitate redevelopment once nesting bird season has finished	LOW	N	-	C3
1971	Golden Cypress	Healthy specimen. Nesting birds present	Remove to facilitate redevelopment once nesting bird season has finished	LOW	N	-	C3
<b>WOODED AREA</b>							
WG1		Obstructing trees on rear boundary edge: 1x Horse Chestnut, 2x Alder, 1x Ash, 1x Single-stem Sycamore, 1x Multi-stemmed Sycamore. All mature specimens touching buildings, obstructing maintenance or overhanging dead wood.	Crown lift, remove dead wood, reduce end weight as necessary	MEDIUM	N	500 Estimated	B2
WT2	Sycamore	Moderate health. Branch stubs from possible third party pruning to remove obstructive growth.	Remedial prune branch stubs	LOW			
WT3	Sycamore	Fallen stump with low, obstructing regrowth	Remove regrowth	LOW			
WT4	Sycamore	Low crown over third party property.	Crown lift to 4m from ground level.	LOW			

WT5	Sycamore	Standing dead wood with Dryads Saddle fungal infection.	Monitor	LOW			
<b>WT6</b>	<b>Sycamore</b>	<b>Pocket of decay at base of stem</b>	<b>Dismantle, fell and remove</b>	<b>MEDIUM/ HIGH</b>			
WT7	Oak	Over hanging third party access road. Branch stubs from the removal of encroaching growth.	Remedial prune branch stubs. Crown lift to 5m from ground level	MEDIUM			
<b>Tag/Ref No.</b>	<b>Species</b>	<b>Observations</b>	<b>Recommendations</b>	<b>Safety Priority</b>			
WT8	Sycamore saplings	Self-set. Dying back.	Coppice	LOW			
WT9	Sycamore saplings	Self-set. Dying back	Coppice	LOW			
WT10	Beech	Branch stubs from third party pruning of encroaching growth.	Remedial prune branch stubs. Crown lift to 5m from ground level.	MEDIUM			
WT11	Ash	Mature specimen. Twin leader. Developing cavity in fork.	Monitor	MEDIUM			
WT12	Beech	Good annual extension and leaf size. Debris around base. Ivy establishing on stem	Sever Ivy. Remove debris. Remedial prune previous encroaching growth removal.	LOW			
WT13	Beech	Exposed due to felling of neighbouring Beech. Dead wood present	Remove large dead wood.	LOW			
WT14	Beech	Felled in recent times, Lying stem still present. Unsure of reasons for the fell.	For records only.	-			
WT15	Beech	Growing outside of fence line, unsure of ownership. Developed cavity in main stem.	If NHS liability, recommend inspection of cavity to ascertain extent of decay	MEDIUM			
WG15	2x Sycamore	Low amenity trees. Previously lopped back, now creating obstruction with low regrowth over third party access road.	Possible neighbourly gesture to remove the trees, although structurally sound	LOW			
WT16	Sycamore	Mature specimen. Lower growth historically lopped back.	Remedial prune, crown lift to 5m from ground level. Remove any large dead wood.	MEDIUM			

WT17	Sycamore	Appears to be slowing in vigour and stressed.	Monitor for further decline Fell and remove	MEDIUM			
WT18	Sycamore	Mature. Ivy covered stem. Secondary growth obstructing street light.	Crown lift to 5m from ground level and cut back from street light. Sever Ivy at 1.5m. Remove large dead wood.	MEDIUM			

### **15 Root Protection Area (RPA) or Tree Protection Zone (TPZ) Spreadsheet**

<b>Tag/ Ref Number</b>	<b>Species</b>	<b>Diameter at 1.5m (mm)</b>	<b>Minimum Radius of RPA from tree stem (m)</b>	<b>Total Area of Polygon to be used for RPA (m<sup>2</sup>)</b>
G4	3x Lawsons Cypress	170 86 130	2.4	18
G6	8x Holly, 2x Ash self-sets, 1x Lawsons Cypress, 1x Buddleia, 2x Elm	150 176 160 60 133	2.1	14
G9	3x Rowan	206 200 150	2.4	18
Woodland Area	Mixed deciduous	Estimated 650	7.8	191

RPA distances within groups can also be over-lapped

The Local Authorities Arboriculturalist must previously agree soil disturbance within these safety areas and also the clients Arboriculturalist should be present on site throughout the work to observe and advise when necessary.