

- Yorkshire Water Notes**
- All adoptable sewer works and material to be in accordance with the "Code for Adoption". The relevant British/European and Yorkshire Water's Standards/Requirements/Addendum to the Mechanical and Electrical Specification and Kitemarked.
  - Manhole covers shall/must have a clear opening of 600mm and shall be Class D400 to BS EN 124 with 150mm deep frames in highways.
  - Filled ground must be filled and consolidated under the supervision and to the satisfaction of Yorkshire Water before any sewer works are carried out.
  - Yorkshire Water is not obliged to accept filter drain/land drainage run-off into the public sewer network or adoptable drainage system (directly or in-directly). An alternative method of disposal of the land drainage run-off will therefore be required and you will have to liaise with the Local Authority, Land Drainage Section regarding the disposal of the filter drain/land drainage run-off.
  - The adoptable sewers should be a minimum of 1m and manholes 0.5m from kerb faces and service margins.
  - Sewers must have 5 metres clearance from trees and hedges or the width of the canopy at mature height.
  - Sewers to be laid in Class "S" bedding (150mm granular bed and surround). Where depth of cover to top of the sewer is less than 1.2m in highways and verges (or less than 900mm in none vehicular access areas) then a concrete slab should be provided above the granular bed and surround.
  - Bedding and backfill material to conform to the requirement of Water Industry Specification 4-08-02 (Table A2).
  - Yorkshire Water policy is that Type "C" brick manhole and 1050mm dia manhole rings are not preferred. Instead it is preferred that you use a type "B" manhole with 1200mm dia or 1500mm dia rings, with the opening sited over the channel where depth of cover to pipe soffit is 1-1.5m.
  - Adoptable plastic sewer pipes to be BS1 Kitemarked (Certified to WIS 4-35-01 and BS/EN13476). Adoptable plastic sewer pipes to be laid in maximum 3 metre lengths unless there is a specific operational need to lay longer lengths. Plastic channel sections in manholes are not acceptable and Yorkshire Water would require clay ware channel in manholes.
  - The minimum crushing strength for clay pipes should be as follows: 100mm dia. 40kN/m, 150mm dia. 40kN/m, 225mm dia. 45kN/m and 300mm dia. 72kN/m. The minimum crushing strength for concrete pipes should be (Class 120 to EN 1916/BS5911-1:2002). Plastic pipes should conform to WIS 4-35-01 and BS EN13476.
  - Where a B125 cover and frame has been approved, this must not be coated in plastic and must have lifting eyes suitably sized to accommodate standard lifting keys. Screw down covers are not acceptable.
  - There must be enough clearance at crossovers to accommodate bedding to both pipes, approx. 300mm. If crossover is near the rocker then the clearance needed may need to be increased.

- General Notes**
- This drawing is to be read in conjunction with all relevant ARP and Architects drawings and project specifications.
  - All drainage works shall be carried out in accordance with the relevant parts of BS EN 752 "Drains and Sewer Systems Outside Buildings", the current Building Regulations and the Local Authority Building Control specifications and requirements.
  - The location, size and depth of all existing drains/sewers and services shall be established by the contractor prior to commencement of works on site. Any discrepancies from the information indicated on these drawings shall immediately be brought to the attention of the engineers.
  - All levels and dimensions shall be verified on site prior to commencement of any works. Any discrepancies shall immediately be brought to the attention of the engineers.
  - All pipes shall be laid with soffit level. All manhole/inspection chamber invert levels shown are for the outlet pipe (unless specified otherwise). All pipe runs shall be laid to the levels indicated.
  - All private foul and surface water pipes to be 100mm Ø unless stated otherwise.
  - All connections to public sewers to be a minimum of 150mm A.
  - All private manholes within drives to have B125 covers with concrete collar, all others to be A15.
  - All private backdrop manholes to be 900mmØ PCC chambers unless stated otherwise.
  - 450mmØ chambers for depths greater than 1.2m, restricted access opening to 350mm is required for safety reasons.
  - All RWP's & SWP's connections to be 100mm dia (unless specified otherwise by the Architect). Gully connections to be 150mm dia.
  - All RWP's, SWP's and connections are shown indicatively or to the latest Architects drawings. Position of down pipes must be confirmed from Architects drawing before laying underground pipework. All down pipes should be provided with a roddable access point above the FFL.
  - All private drainage laid within 1m from tree canopies and hedges to have concrete bed and surround.
  - Filled ground or soft spots must be excavated, backfilled and consolidated before any drainage works are carried out.
  - All excavations in areas of high water tables and granular materials with high sand/silt contents shall be wrapped with a suitable geotextile filter membrane to prevent migration of sands/silts. Full height clay slanks across trenches and/or at manhole locations at 25m intervals to restrict water movement along the excavation shall be provided.
  - No water should be allowed to discharge from any private drives onto the adoptable highways. All private gullies and channel drainage positions shown may vary to suit on site working conditions.
  - Do not scale from this drawing.

Nominal Diameter (mm)	Effective Length (m)
150-600	0.6
675-750	1.0
Over 750	1.25

**ARP ASSOCIATES**  
 Chartered Consulting Engineers  
 Northwest House • 5 & 6 Northwest Business Park • Servia Hill, Leeds • LS6 2QH  
 0113 245 6498 • 0113 244 3864 • Leeds@arpassociates.co.uk • www.arpassociates.co.uk  
ARP Associates is a trading division of ARP Geotechnical Ltd, a company registered in England and Wales with company number 3773831, whose registered office is at 5/6 Northwest Business Park, Servia Hill, Leeds LS6 2QH

TITLE  
**TYPICAL DRAINAGE DETAILS SHEET 1 OF 2**

PROJECT  
**BLEACHCROFT WAY**

CLIENT  
**HARRON HOMES**

DRAWING STATUS  
**PRELIMINARY**

Scale	Date	Drawn
1:500 @ A1	AUG 22	JMG
	Chk.	MI

Org. No. **0873/82/07.01** Rev /

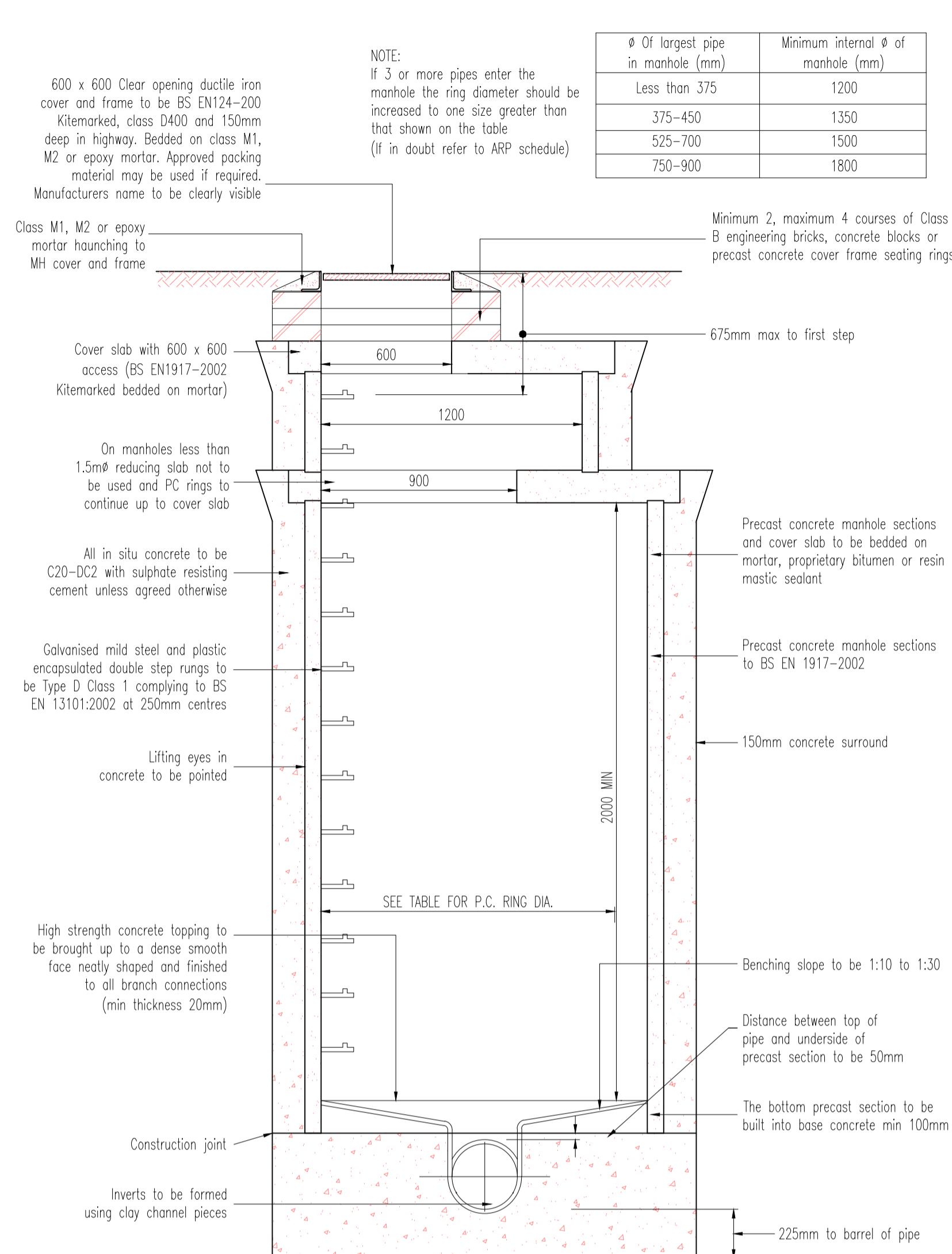

**TYPICAL MANHOLE DETAIL - TYPE A**

Max depth from ground level to soffit of pipe 3.0m to 6.0  
The design of the manhole will need to comply with the undertakers safety policy

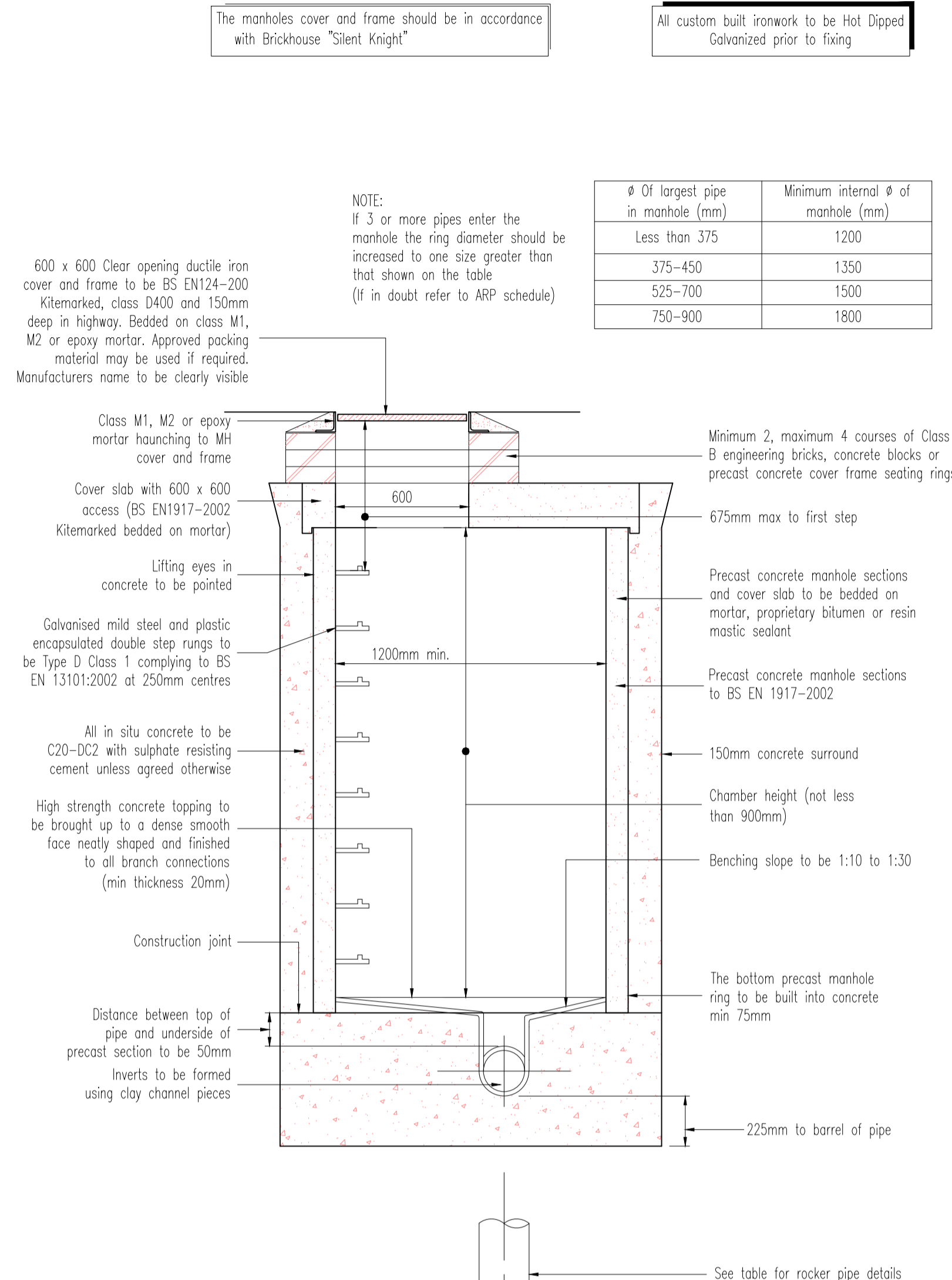

**TYPICAL MANHOLE DETAIL - TYPE B**

CODES FOR ADOPTION  
Max depth from ground level to soffit of pipe 3.0m  
The design of the manhole will need to comply with the undertakers safety policy

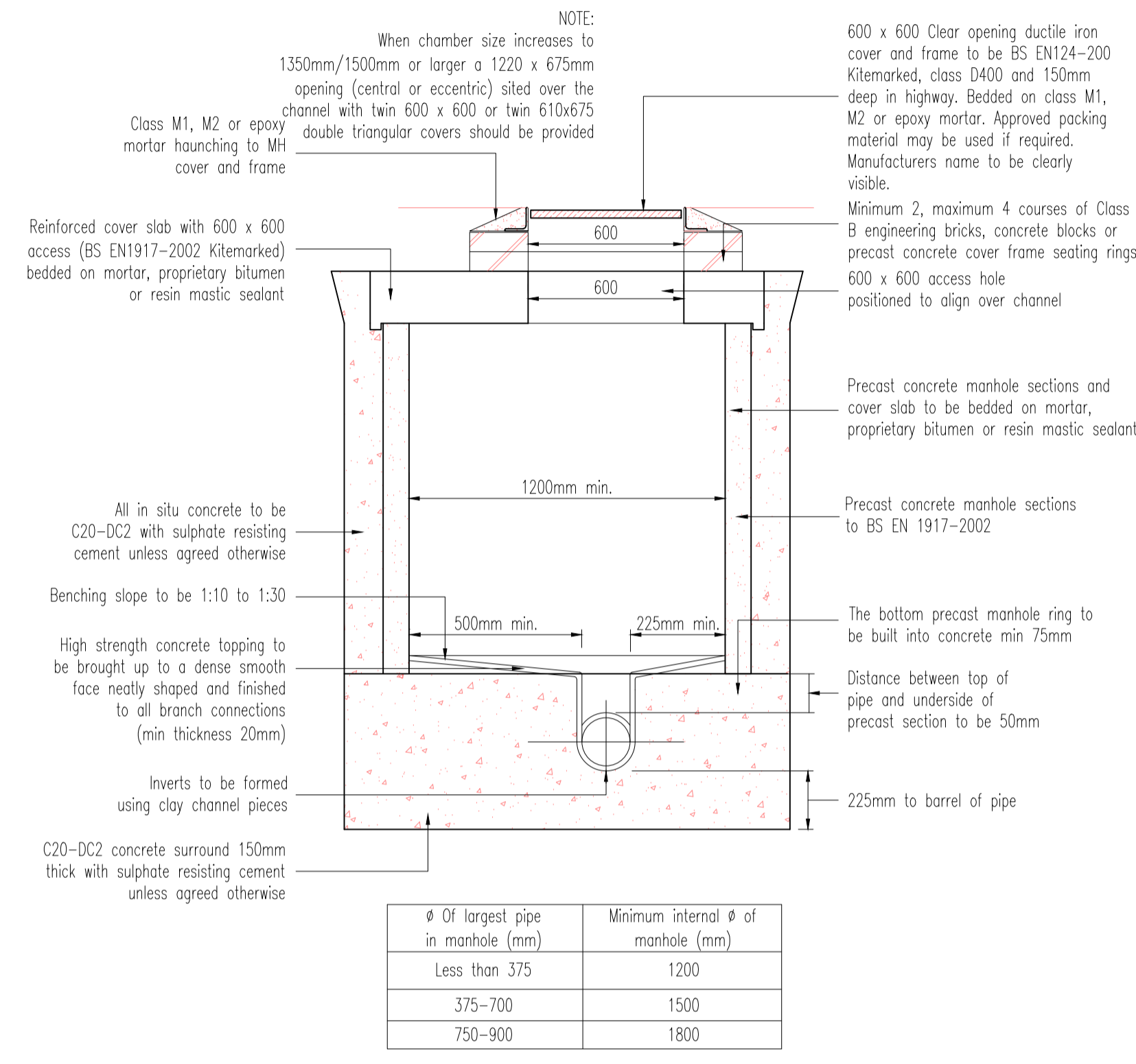

**TYPICAL MANHOLE DETAIL - TYPE C SHALLOW MANHOLE**

Max depth from ground level to soffit of pipe 1.0m to 1.5m  
The design of the manhole will need to comply with the undertakers safety policy

The manholes cover and frame should be in accordance with Brickhouse "Silent Knight"

All custom built ironwork to be Hot Dipped Galvanized prior to fixing

NOTE: If 3 or more pipes enter the manhole the ring diameter should be increased to one size greater than that shown on the table (If in doubt refer to ARP schedule)

Ø Of largest pipe in manhole (mm)	Minimum internal Ø of manhole (mm)
Less than 375	1200
375-450	1350
525-700	1500
750-900	1800

NOTE: When chamber size increases to 1350mm/1500mm or larger a 1220 x 675mm opening (central or eccentric) sited over the channel with twin 600 x 600 or twin 610x675 double triangular covers should be provided

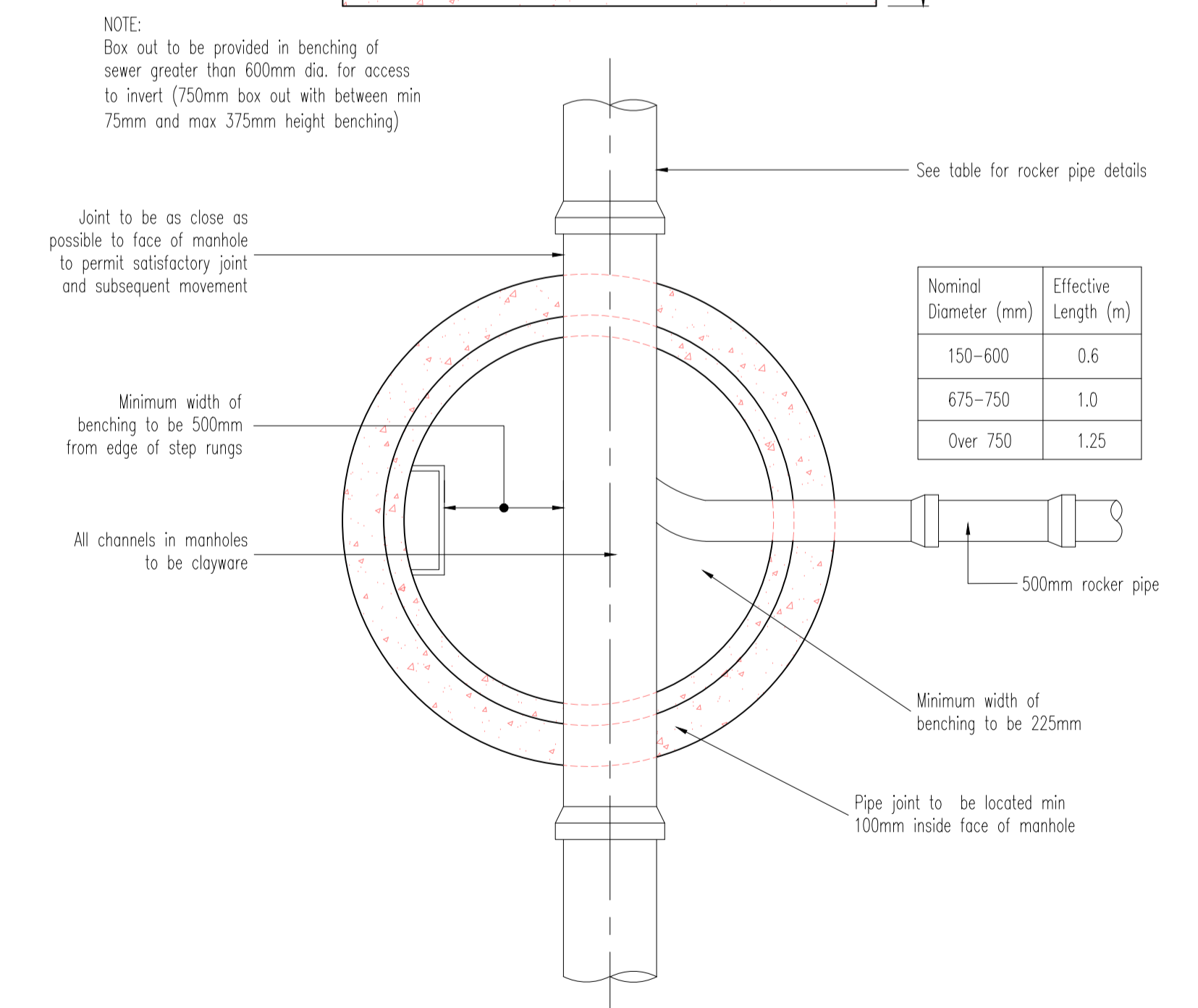
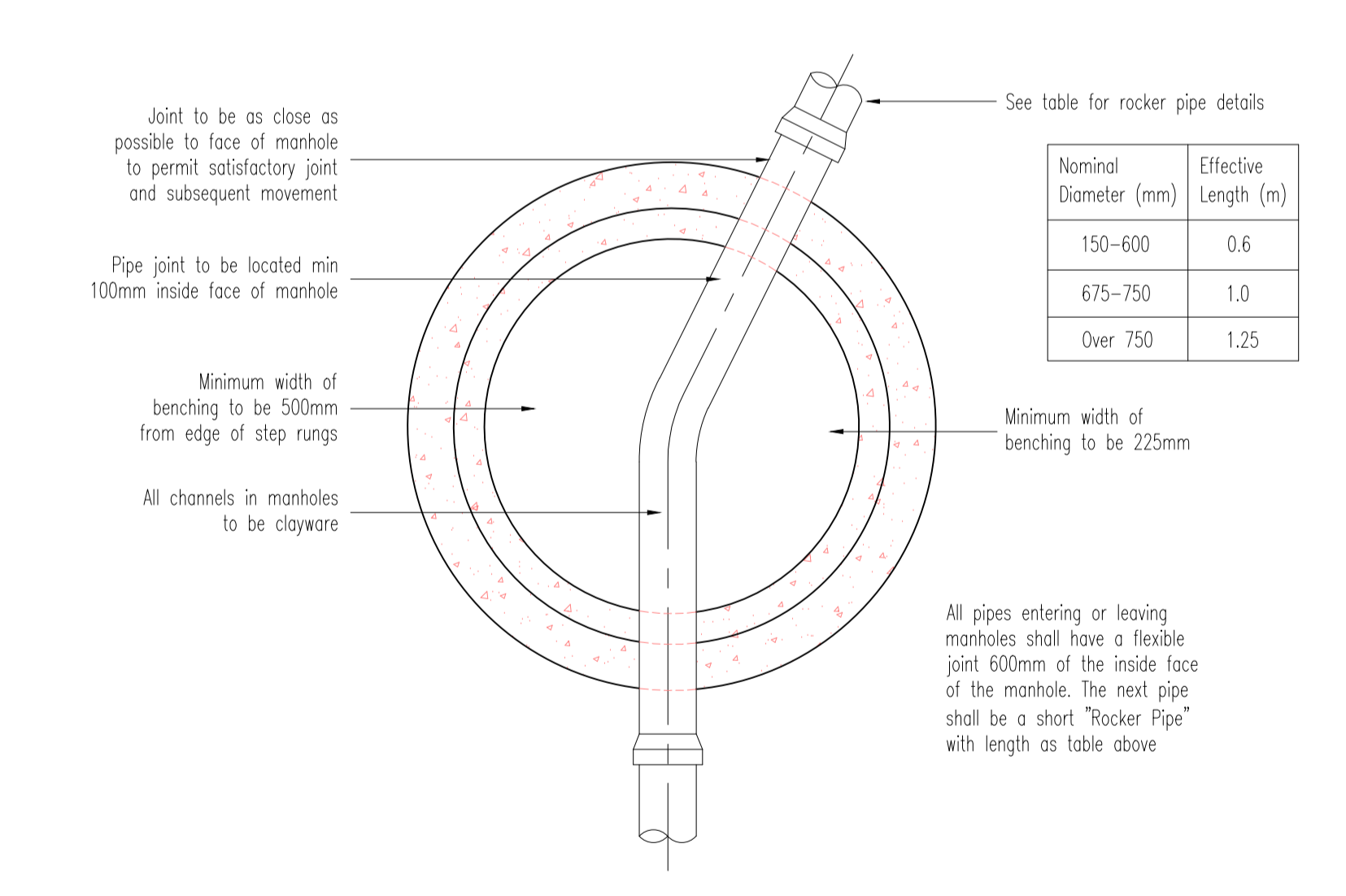
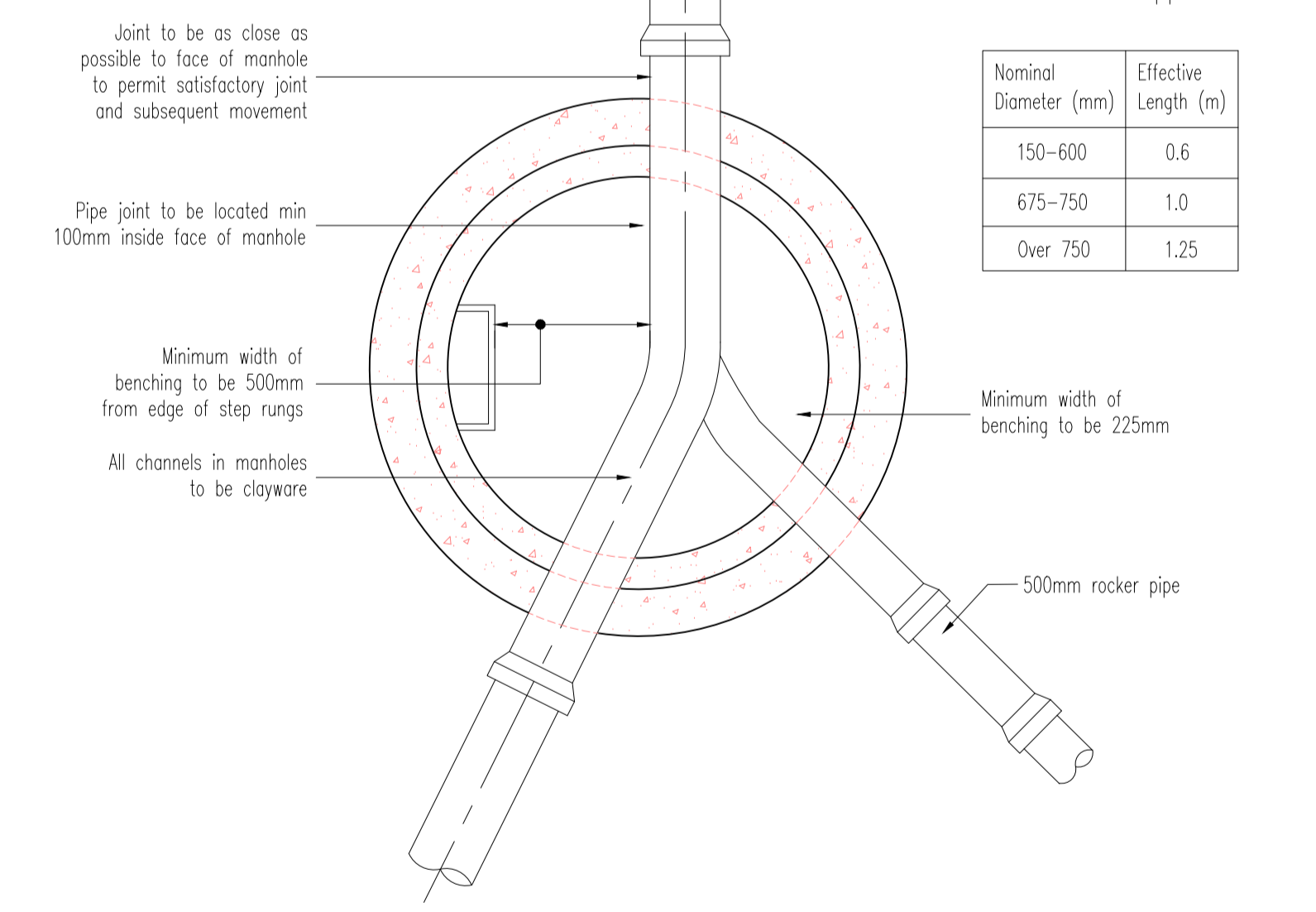

**TYPICAL MANHOLE DETAIL - TYPE A**

Max depth from ground level to soffit of pipe 3.0m to 6.0  
The design of the manhole will need to comply with the undertakers safety policy