

TYPICAL MANHOLE CONSTRUCTION

Type A1 (Design and Construction Guidance)

For use on manholes of depth from cover level to soffit level between 3000mm and 6000mm

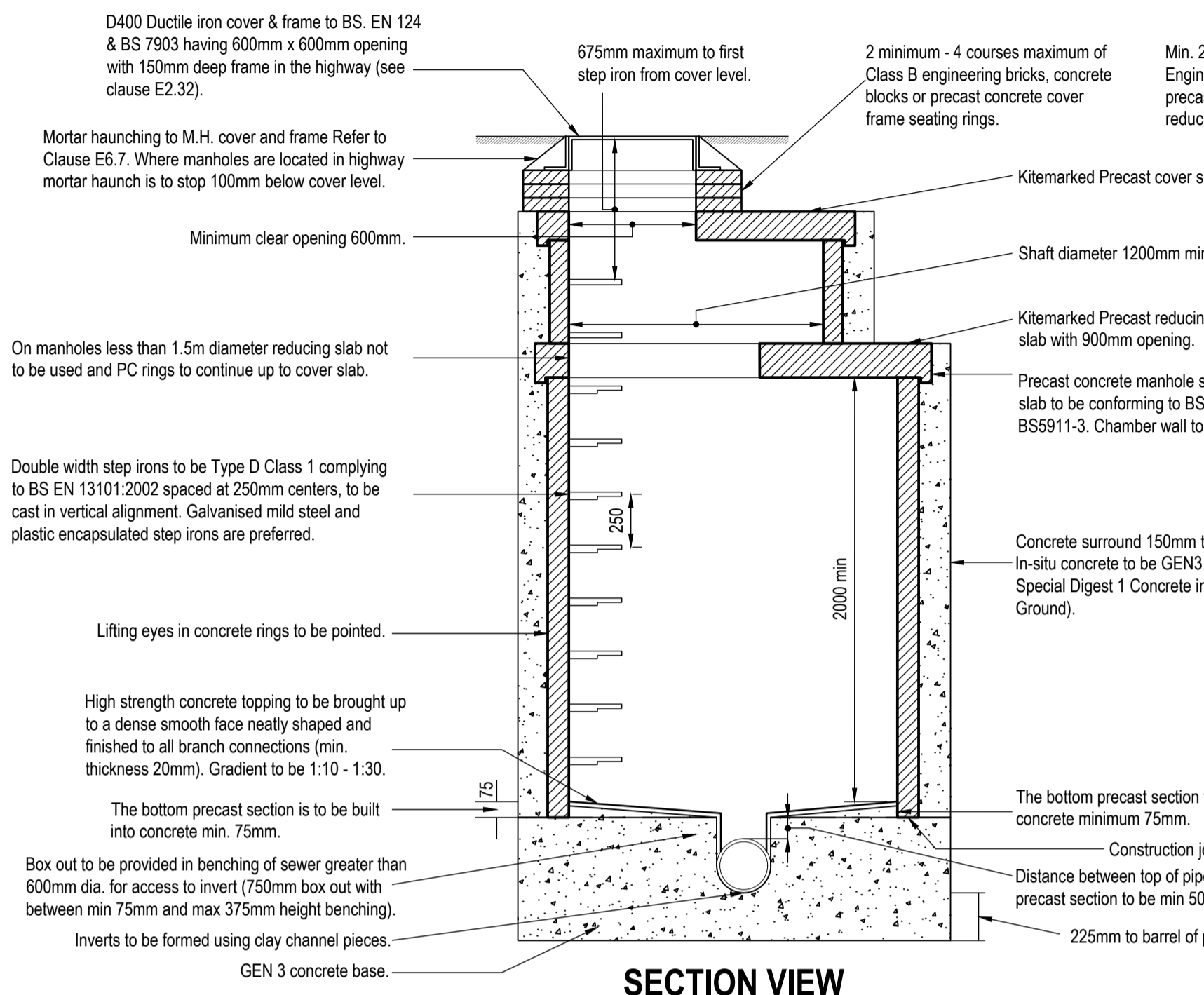

SECTION VIEW

TYPICAL MANHOLE CONSTRUCTION

Type B (Design and Construction Guidance)

For use on manholes of depth from cover level to soffit of pipe 3000mm.

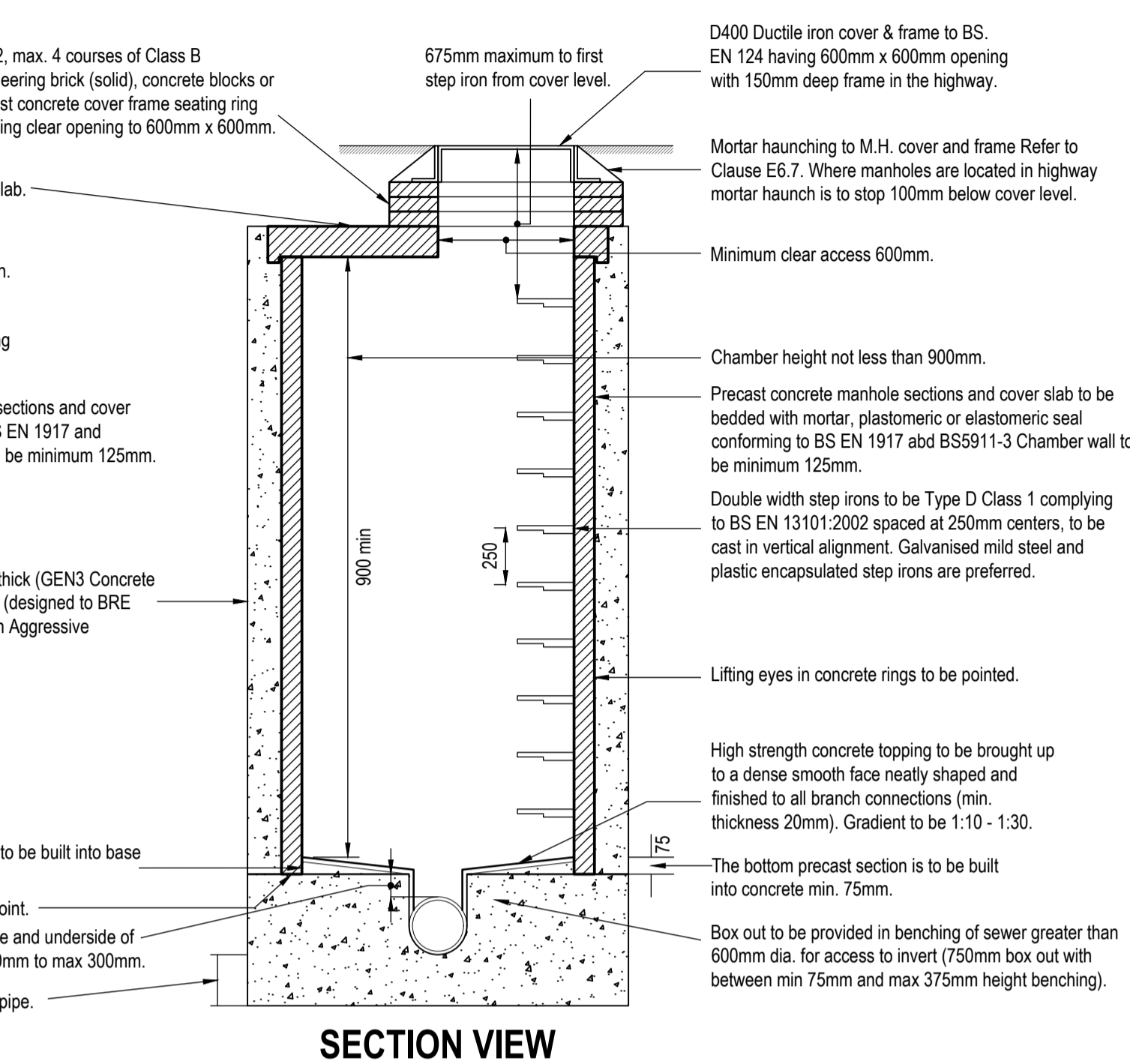

SECTION VIEW

SHALLOW MANHOLE CONSTRUCTION

Type C (Design and Construction Guidance)

For use on manholes of depth from soffit to cover level less than 1.5m

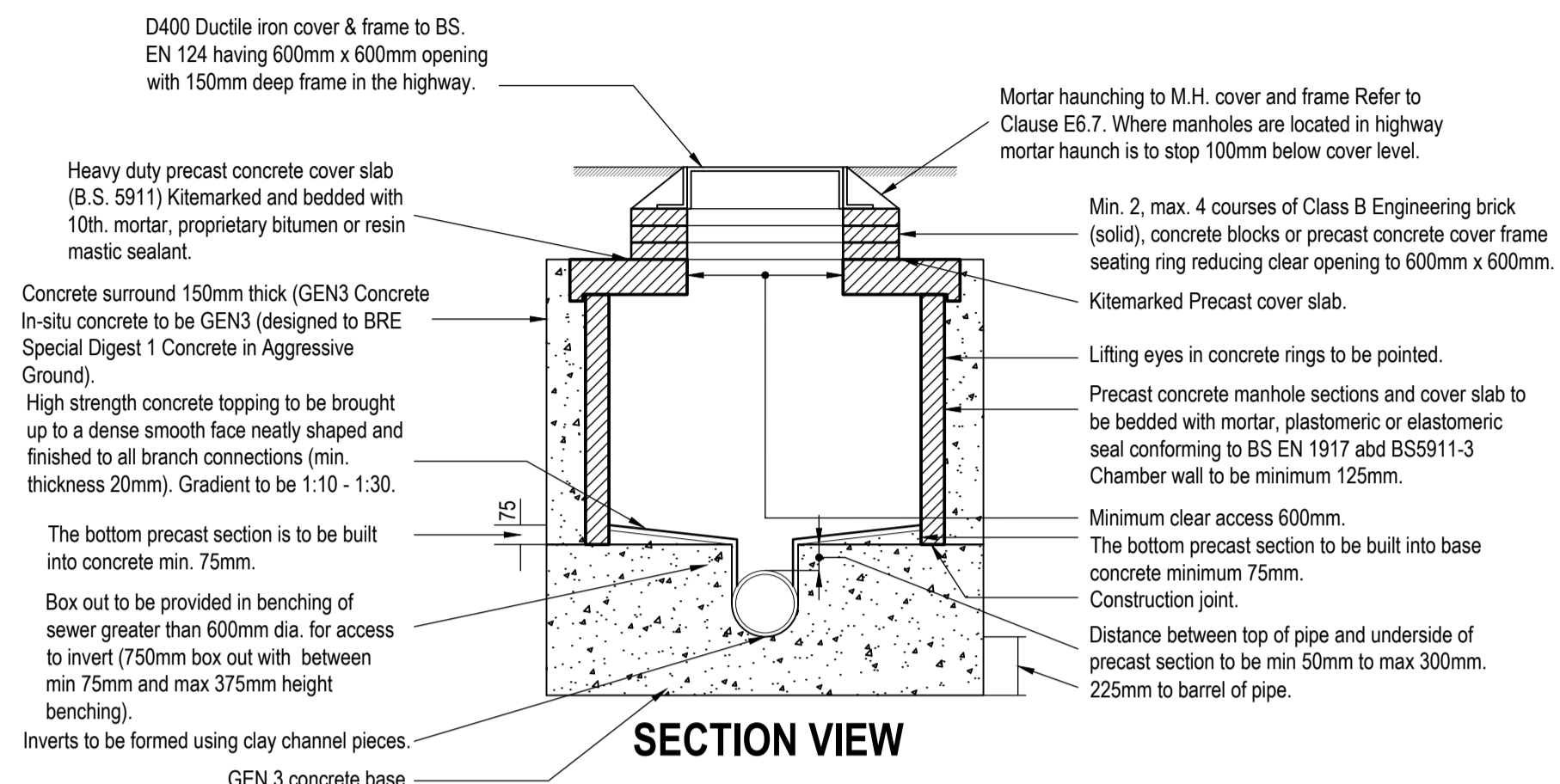

SECTION VIEW

NOTE: Where Type C manholes are 1500mm or greater in diameter a double twin 1220mm x 675mm cover and frame is require directly over the channel

TYPICAL WIDE WALL MANHOLE CONSTRUCTION

Type A Alternative Wide Wall Manhole Construction (Design and Construction Guidance)

For use on manholes of depth from cover level to soffit level between 3000mm and 6000mm. Wide wall manhole ring construction

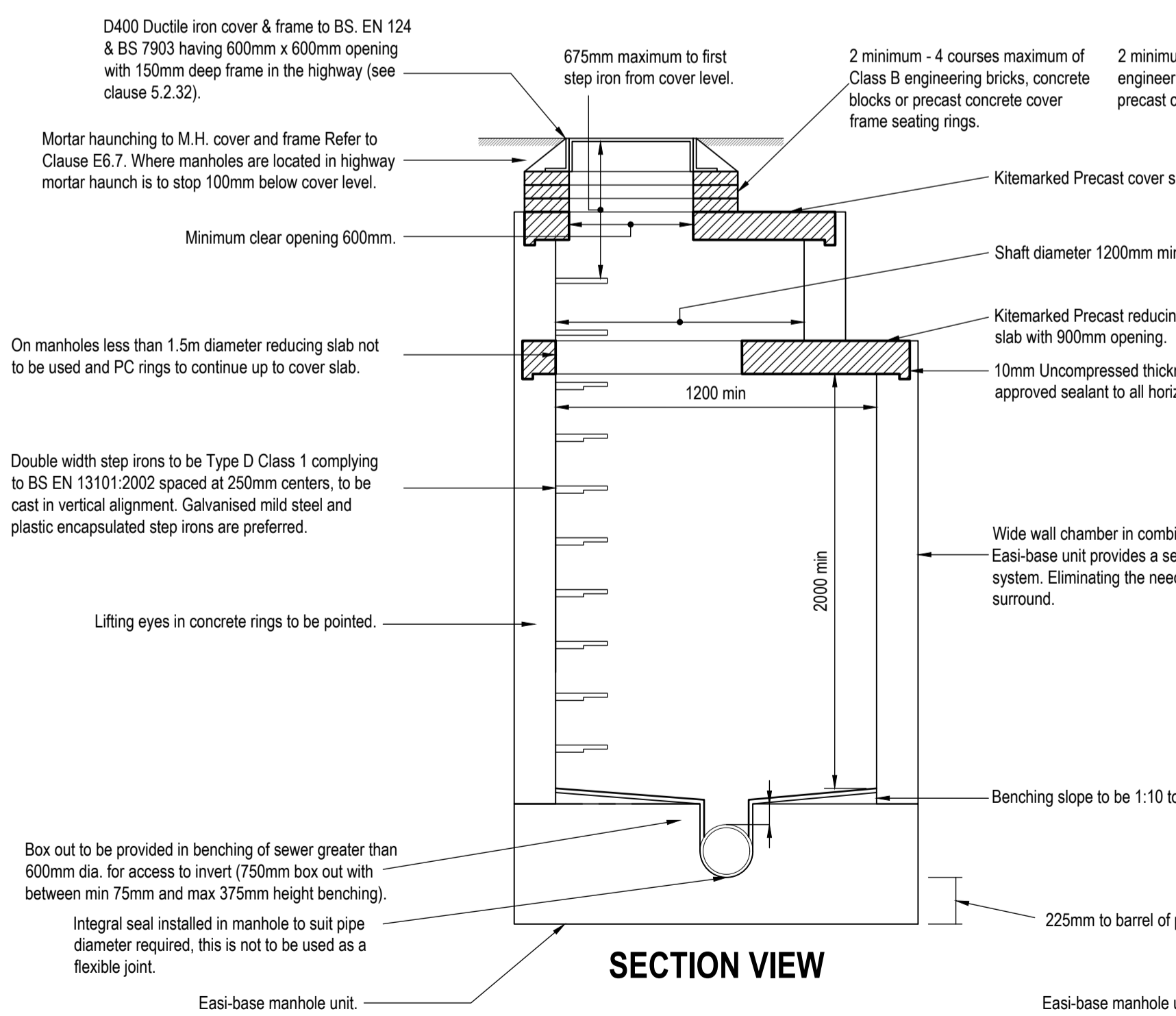

SECTION VIEW

TYPICAL WIDE WALL MANHOLE CONSTRUCTION

Type B Alternative Wide Wall Manhole Construction (Design and Construction Guidance)

For use on manholes of depth from cover level to soffit of pipe 3000mm. Wide wall manhole ring construction

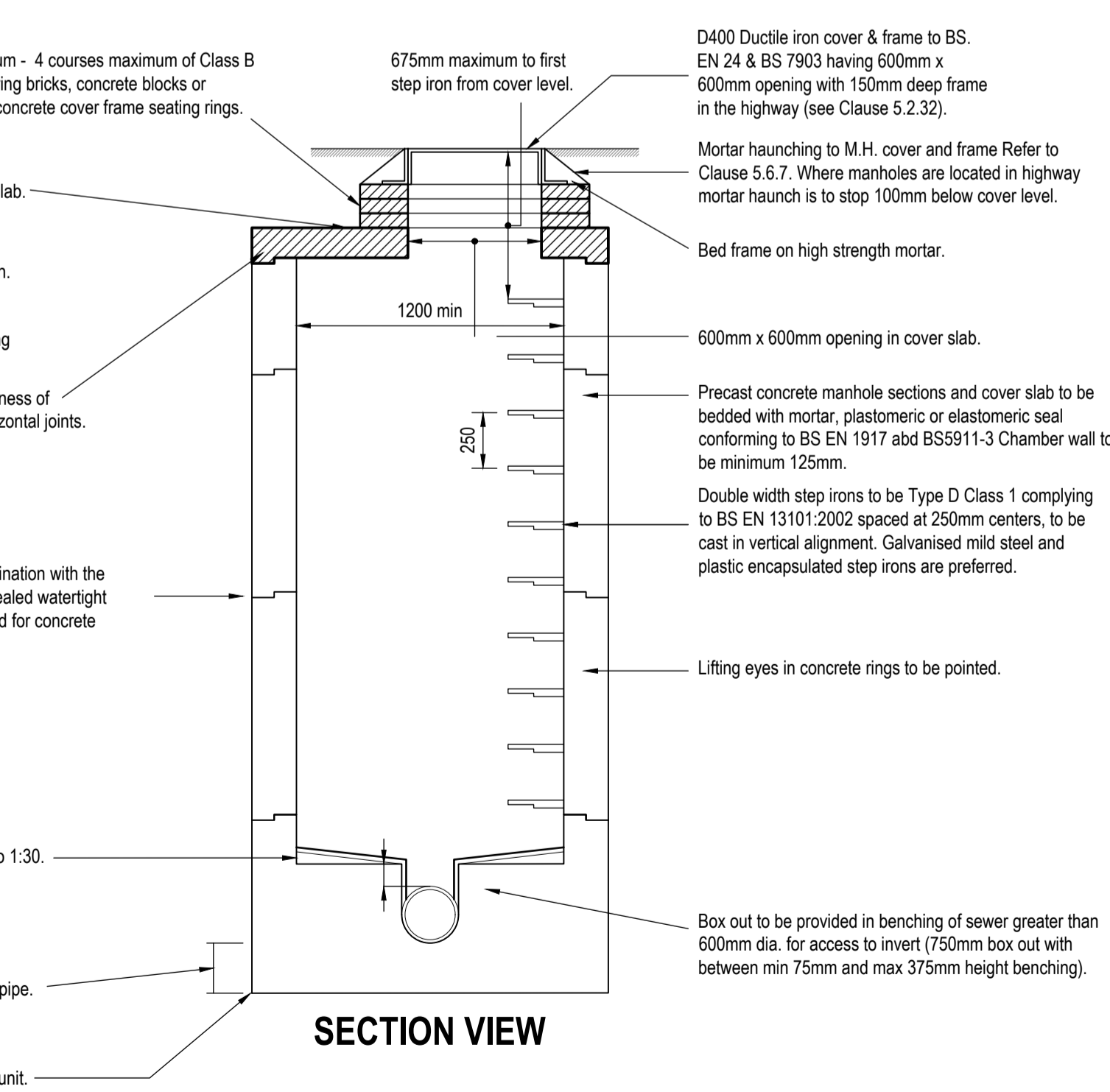

SECTION VIEW

SHALLOW MANHOLE CONSTRUCTION

Type C Alternative Wide Wall Manhole Construction (Design and Construction Guidance)

Construction of manholes where depth from soffit to cover level less than 1500mm

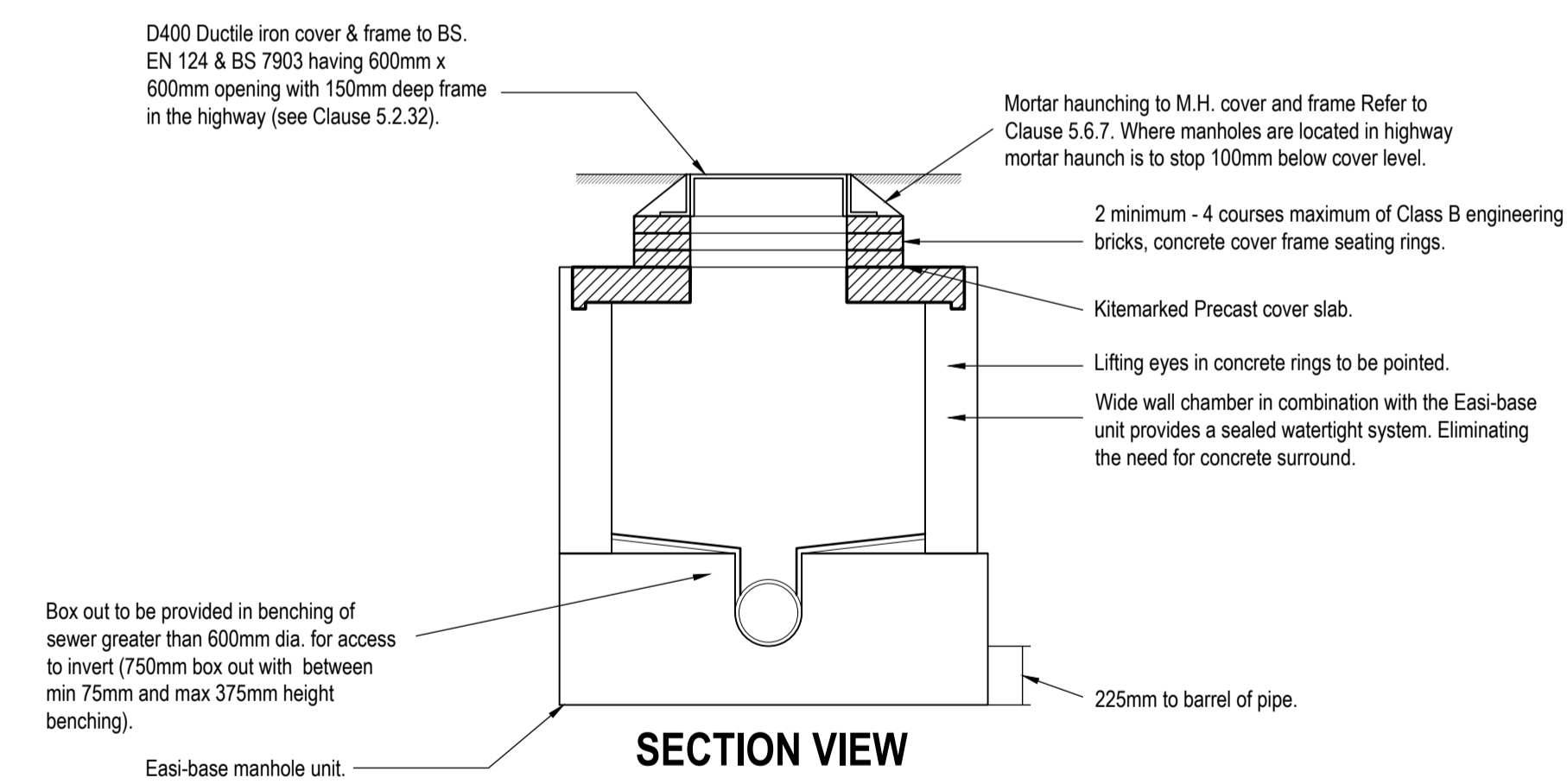

SECTION VIEW

NOTE: Where Type C manholes are 1500mm or greater in diameter a double twin 1220mm x 675mm cover and frame is require directly over the channel

Manhole Diameters	
Nominal internal diameter of largest pipe in manhole (mm)	Minimum nominal internal dimension of manhole (mm)
Up to 300	1200
375-450	1350
500-700	1500
750-900	1800
Greater than 900	Specific detailed drawing required

NOTE: Where manholes have backdrop connections a full 150mm concrete surround to the manhole is required.

Notes:

- All pipes shall be either:
A - Vitrified clay to BS EN 295 with a minimum crushing strength as follow :-
150 dia - 40 kN/m
225 dia - 45 kN/m
300 dia - 72 kN/m
B - PVC (certified to WIS 4-35-01 & BS EN 13476)
C - Class 120 concrete to BS 5911-1:2002/EN 1916.
- All pipes should always connect soffit to soffit unless noted otherwise.
- All sewers to have BSI kitemark status (certified to WIS 4-35-01 & BS EN 13476). Maximum pipe length to be 3m. Plastic channel sections in manholes are not acceptable. Clay channel sections shall be used.
- Sewers to be laid in Class "S" Bedding (150mm granular bed and surround). Where depth of cover to top of the sewer is less than 1.2m in highways and verges (or less than 900mm in none vehicular access areas) then a concrete slab should be provide above granular bed and surround.
- Manhole covers shall/must have a clear opening of 600 and shall be class D400 to BS EN 124 with 150 deep frames in highways.
- Pipes entering manholes and road gullies shall have a flexible joint within 600 of the inside the manhole or gully joining with a short Rocker pipe.
- The adoptable sewers should be a minimum of 1m and manholes 0.5m from kerb faces and service margins.
- Sewers must have 5m clearance from trees and hedges
- All trenches in roads and paved areas shall be backfilled with Type 1 DOT granular sub-base material, or other granular material approved by the highway authority.
- Fill ground must be filled and consolidated under the supervision and to the satisfaction of Yorkshire Water before any sewer works are carried out.
- All in situ concrete to be designated mix FND2 to BS 8500-1 unless agreed otherwise.
- The invert levels at the proposed points of connection to existing public sewers shall be checked before any new drains are constructed. Any variation to the levels shown on the drawing shall be notified to Eastwood & Partners.
- The chamber size of manholes with more than one connection in them may need to be increased an increment to accommodate the connections and bends.
- Cover levels are indicative only. Covers to be set to suit camber/gradient of existing and proposed roads.
- Cover slabs must carry the BSI Kitemark or will be rejected by Yorkshire Water Inspector. Where the clear opening of the Kitemarked product is different to that of the cover and frame, a loading bearing slab should be fitted above the cover slab to bring the size down to 600mm x 600mm for the Yorkshire Water specified cover size. Please refer to Concrete Pipe Systems Association (CPSA), Technical Bulletin issued Autumn 2004 for Kitemarked cover slab opening sizes.
- All foul lateral sewers and drains to be 1500 unless noted otherwise.
- Yorkshire Water policy is that Type "C" brick manholes and 1050mm dia manhole rings are not preferred. Instead it is preferred that you use a type "B" manhole with 1200mm dia or 1500mm dia rings, with the opening sited over the channel where depth of cover to pipe soffit is 1 - 1.5m.
- Manhole covers shall/must have a clear opening of 600mm and shall be Class D400 to BS EN 124 with 150mm deep frames in highways.
- Where a B125 cover and frame has been approved, this must not be coated in plastic and must have lifting eyes suitably sized to accommodate standard lifting keys. Screw down covers are not acceptable.
- All adoptable sewer works and material to be in accordance with "Code for Adoption". The Relevant British/European and Yorkshire Water's Standards/Requirements/Addendum to the Mechanical and Electrical Specification and Kitemarked.
- Yorkshire Water is not obliged to accept filter drain/land drainage run-off into the public sewer network or adoptable drainage system (directly or in-directly). An alternative method of disposal of the land drainage run-off will therefore be required and you will have to liaise with the Local Authority, Land Drainage Section with regard to the disposal of the filter drain/land drainage run-off.
- Sulphate resistant cement (C20-DC2) and precast concrete products must be used or a laboratory report provided proving that such precautions are not necessary.
- Bedding and backfill material to conform to the requirement of Water Industry Specification 4-08-02 (Table A2).
- Adoptable plastic sewer pipes to be BSI Kitemarked (certified to WIS 4-35-01 and BS EN 13476). Adoptable plastic sewer pipes to be laid in maximum 3 metre lengths unless there is a specific operational need to lay longer lengths. Plastic channel sections in manholes are not acceptable and Yorkshire Water would prefer clayware channel in manholes. We have found that plastic channels are difficult to set in concrete because they float and a satisfactory finish cannot be obtained on the benching.
- The clearance of the crossover points (min 300mm) between the surface water, foul sewers, rising main and other services should be sufficient clearance to provide 150mm surround of a certain mm that exceeds this (200mm).
- All adoptable laterals to be 1500 and VC unless stated otherwise

P01	First Issue.	GH	CH	31.03.23
REV	DESCRIPTION	SIG	CHK	DATE

DUCHY HOMES

DARTON LANE

S104 ADOPTABLE MANHOLE DETAILS - SHEET 1

St Andrew's House
23 Kingfield Road
Sheffield, S11 9AS

T: 0114 255 4554
E: mail@eastwoodce.com
eastwoodce.com

ECE PROJECT No	SCALE AT A1	STATUS	SUITABLE FOR
47509	NTS	S0	Initial
DRAWING NUMBER		REV	
47509 - ECE - XX - XX - DR - C - 0025	P01	Project	Originator
Zone	Level	Type	Role