



Station Road, Royston Arboricultural Impact Assessment

Report Ref: TEP.4186.001
April 2014

Genesis Centre
Birchwood Science Park
Warrington
WA3 7BH

T: 01925 844004
F: 01925 844002
E: tep@tep.uk.com
W: www.tep.uk.com



**Station Road, Royston
Arboricultural Impact Assessment
Report Reference: TEP.4186.001
Version 1.0
April 2014**

**Prepared by:
Tom Popplewell
Arboricultural Consultant**

**TEP
Genesis Centre
Birchwood Science Park
Warrington
WA3 7BH
Tel: 01925 844004
Fax: 01925 844002
e-mail: tep@tep.uk.com**

for

**Aries Trading UK Limited
21 Meyrick Drive
Darton
Barnsley
S75 5PL**

Written:	Checked:	Approved:
TDP	RMG	JGS



**STATION ROAD, ROYSTON
ARBORICULTURAL IMPACT ASSESSMENT**

CONTENTS	PAGE
1.0 INTRODUCTION	1
2.0 THE SITE AND SURROUNDINGS.....	2
3.0 STATUTORY PROTECTION	3
4.0 TREE POPULATION	5
5.0 IMPACTS OF THE PROPOSED DEVELOPMENT	7
6.0 TREE PROTECTION REQUIREMENTS	8
7.0 ARBORICULTURAL RECOMMENDATIONS	10
8.0 SUMMARY	13

APPENDICES

Appendix 1:	Arboricultural Survey Data Sheets
Appendix 2:	Survey Method

DRAWINGS

Drawing 1:	Tree Constraints Plan:	D4186.001
Drawing 2:	Tree Removal Plan:	D4186.002
Drawing 3:	Tree Protection Plan:	D4186.003
Drawing 4:	Temporary Tree Protection Fencing:	D.TREE_FENCING.001



1.0 INTRODUCTION

- 1.1 TEP has been commissioned by Aries Trading UK Limited to conduct an arboricultural survey of land off Station Road, Royston near Barnsley. This report details the arboricultural impact of developing the site according to a nominated layout proposal, subsequent mitigation recommendations and protective measures.
- 1.2 TEP originally surveyed the site in November 2010. At this time, access to some trees was restricted by dense vegetation. Following some clearance of vegetation; the revision of British Standard 5837; a successful Outline Planning Application on the site; and in view of the time that has elapsed, a refresher survey was commissioned to verify and update the survey data. The second survey captured a slightly enlarged site boundary and, accordingly, more trees.
- 1.3 The survey was carried out in October 2013 by means of inspection from ground level by a qualified Arboricultural Consultant. Trees were assessed in accordance with *BS 5837:2012 Trees in Relation to design, demolition and construction – Recommendations*.
- 1.4 Under the British Standard the assessment of trees is made objectively. The categorisation method identifies the quality and value of the existing tree stock.
- 1.5 A topographical survey was used to record the position of trees and vegetation (Ref: S6647). Where the age distribution and species mix of tree cover was relatively uniform, trees were plotted as groups. For the purposes of this report it is assumed that the detail on the drawing is accurate.
- 1.6 A number of trees were not shown on the topographical survey; therefore TEP's surveyor estimated their locations.
- 1.7 4 trees and 1 group of trees were not present which had been recorded during the first survey. For these trees, the original survey data is included for completeness and in order to maintain a coherent and sequential numbering system for all trees.
- 1.8 A total of 17 individual trees (T1-T17) and 8 groups of trees (G1-G8) were surveyed and mapped (refer to Drawing 1). All arboricultural information recorded during the survey is presented at Appendix 1.
- 1.9 The nature of the soils on site was not assessed during the survey. The possibility of minor soil movement due to tree root activity cannot be discounted. Prior to the undertaking of foundation depth calculations the exact location of all trees in relation to structures will be required.

1.10 This report provides the results of the survey and includes the following:

- A schedule of all trees located on, or within influencing distance of the proposed development site (Appendix 1);
- An assessment based on *BS 5837:2012*, of trees in terms of their potential value within any future development. On the basis of this assessment trees have been categorised into one of four categories: A, B, C or U (Appendices 1 & 2);
- An assessment, based on *BS 5837:2012*, of the requirement for protection of trees during the construction phase (Section 6);
- Advice on removal, retention and management of trees (Sections 5 & 7);
- A Tree Constraints Plan detailing tree quality categories, canopy spreads and Root Protection Areas (**RPA**) for all trees surveyed (Drawing 1); and
- A Tree Removal and Protection Plan detailing the development proposals, trees to be retained and removed, tree protection fencing alignment and areas requiring special treatment (Drawing 2).

2.0 THE SITE AND SURROUNDINGS

2.1 The site is off Station Road, Royston. It comprises a roughly triangular plot of unmanaged land between Station Road and Windmill Terrace at the northernmost tip of Royston, which lies to the north-west of Barnsley.

2.2 The survey area is higher than Station Road, which lies in a cutting through exposed rock where it passes the site. The land falls steeply down to the road in the west from a highpoint close to the southernmost tip of the site. The remainder of the site also generally falls from south-east to north-west with a maximum height difference of just under 10m.

2.3 The site is unmanaged and currently unused. It contains self-set and ruderal vegetation. A small number of current or recently used desire lines were noted across the site, although no signs indicating a right of way were observed. An unmade track to the east of the site (Windmill Terrace) provides vehicular access to a small number of properties to the north of Cutts Field View.

2.4 Weather conditions during the survey were dry and bright.

2.5 Inspection of trees along the western boundary slope was restricted in some cases by dense vegetation and proximity to the highway. These trees were surveyed insofar as was possible from accessible areas of the site and from the public highway. All trees in this area are small and/or young and this limitation is not considered to compromise the validity or conclusions of the survey or report in any way.

Development Proposals

- 2.6 The proposed development includes a residential scheme of 18 units. This will be accessed from Station Road via a proposed new access road. Off-street parking, gardens and other built infrastructure will also be provided.
- 2.7 The detail of the proposals is shown on Drawing 2 and is based on the proposed site plan (Ref:597-SKL-02) supplied by Adams Planning and Design.

3.0 STATUTORY PROTECTION AND GUIDANCE

National Planning Policy Framework (NPPF)

- 3.1 The NPPF assumes protection of all ancient woodland and veteran trees unless it can be clearly demonstrated that the need of, or benefits of, development outweigh the loss. In this respect ancient woodland is defined as an area which has been wooded continuously since at least 1600 AD and a veteran as a tree of exceptional value for wildlife, in the landscape, or culturally because of its great age, size or condition
- 3.2 On this site there is no ancient woodland.
- 3.3 One pear tree (T16) has veteran characteristics including large size for its species; evidence of previous coppicing or regrowth from a failed stump (suggesting a greater age than is cursorily apparent); small pockets of decay; and harp regrowth from a failed stem. The tree cannot properly be described as a Veteran but it clearly represents the most substantial and immediate potential for the development of a Veteran tree on the site. It is also the most valuable individual for many of the same reasons and its protection is implicitly prioritised by the NPPF.

Tree Preservation Orders & Conservation Area Designations

- 3.4 Local authorities reserve the right to create Tree Preservation Orders (TPO) to protect the amenity value conferred to a location by a tree or group of trees. Where a TPO is in force, lopping, topping, felling, uprooting or wilful damage caused to a tree is prohibited and such actions may be prosecuted and incur an unlimited fine. Works to TPO protected trees must only be undertaken with the written consent of the local authority.
- 3.5 Barnsley Metropolitan Borough Council have been contacted regarding confirmation of any trees on or immediately adjacent to the site that are subject to Tree Preservation Orders or Conservation Area status. At the time of completion of this report no response has been received.

Protected Species – Bat

- 3.6 Mature trees often contain cavities, crevices and hollows which are a potential habitat for roosting bats. Bats are afforded protection under Schedule 5 of the *Wildlife and Countryside Act 1981* (as amended), as well as under Schedule 2 of the *Conservation of Species and Habitats Regulations 2010*, and as such causing damage to a bat roost constitutes an offence.

- 3.7 A preliminary ground level appraisal of the wildlife habitat value of each tree was undertaken as part of the arboricultural survey. Mature hawthorn and elder and dead trees within group G4 were noted as having features suitable to support roosting bats.
- 3.8 If any works are to be carried out to these trees then a more detailed, aerial visual assessment and/or dusk and dawn surveys should be undertaken by a suitably experienced ecologist to determine the presence/absence of roosting bats prior to any tree works being undertaken.
- 3.9 Should the presence of a bat roost be suspected whilst undertaking works on any other trees and groups on site, operations must be halted until a licensed bat handler or ecologist can provide advice.

Protected Species - Birds

- 3.10 Trees are a potential habitat for nesting birds, which (as well as their nests and eggs) are protected under the *Wildlife and Countryside Act 1981* (as amended). This makes it an offence to intentionally or recklessly, damage or destroy an active birds nest or any part thereof.
- 3.11 Due to the suitability of the trees within the survey boundary for nesting birds, all tree work should ideally be undertaken outside the bird nesting season (British bird nesting season: March to August inclusive).
- 3.12 If this is not possible then a detailed inspection of each tree should be undertaken by a qualified ecologist immediately prior to the arboricultural works. Should an active nest be found (being built, containing eggs or chicks) then any work likely to affect the nest must be halted until the nest becomes inactive.

National House Building Council

- 3.13 This report has been written in accordance with, and to satisfy the requirement of BS 5837:2012.
- 3.14 The nature of the soils on site was not assessed during the survey. The possibility of soil movement due to tree root activity cannot be discounted.
- 3.15 A number of trees were not shown on the topographical survey (Ref: S6647) that was used to record the position of trees and groups; therefore TEP's surveyor estimated their locations. Prior to the undertaking of foundation depth calculations the exact location of all trees in relation to structures will be required.
- 3.16 Any discrepancies in tree location or apparently omitted trees will require further discussion with a qualified Arboricultural Consultant prior to drafting technical or contract documents.

4.0 TREE POPULATION

- 4.1 13 individual trees (T1-T17) [sic] and 7 groups of trees (G2-G8) were recorded within influencing distance of the site. A schedule of all trees and groups in terms of species, condition, age, management recommendations and *BS 5837:2012* quality categories is provided at Appendix 1.
- 4.2 4 trees (T6, T7, T11 and T12) and 1 group (G1) were not present during the second site visit. These were silver birch and goat willow with low value according to the original survey. This report makes no comment or conclusion regarding timing, reason or impact of the removal of these trees.

North-western boundary trees

- 4.3 Trees along the north-western boundary form a thick vegetation buffer that screens the adjacent property. The trees follow the lowest point of the site and are mostly within the boundary. T14, T15 and G7 were noted outside the boundary but within 1m of the site. These trees all influence the site in terms of root extension, overhanging branches and their influence on the appearance and amenity of the site (including shading) although each of these effects is considered to be minor.
- 4.4 T1 is one of the largest trees on the site. It is a sycamore that sits at the junction of Station Road and the driveway to a property to the immediate north of the site. It is basally multi-stemmed but in good condition, with stems rooting separately into the bank. It is prominently visible at the roadside and makes a contribution to the green appearance and amenity of the highway corridor.
- 4.5 Further east, the boundary is marked by middle aged sycamore and hawthorn (G5) and a dense thicket of damson (G6). These augment a thin boundary planting of hawthorn (G7) which forms a lapsed hedge and occasional larger individuals of cypress and sycamore (T14 and T15). Together, these trees form an effective boundary screen as well as good habitat opportunities and shelter for local wildlife.
- 4.6 Towards the eastern end of the boundary, T16 has the outward appearance of a small cluster of pear trees. It is in fact a single mature tree with multiple stems. One stem has failed towards the north whilst retaining a viable connection with the parent rootstock. This stem has since re-sprouted in a form known as harp regrowth. This form is not necessarily unstable where subsequent rooting is possible but the aerodynamic shelter afforded by the tree's location within a larger group is likely to be mutually beneficial.
- 4.7 Tree T16 comprises a group of three separately rooted stems or stem clusters, each with a small area of wounded or decayed wood towards the interior of the group. This arrangement is commonly an indication of coppicing and may suggest growth from a common parent stem or stool that has since decayed. Pear is not a commonly coppiced species and it is possible that the surveyed stems share a common parent that has been felled or otherwise failed at some point in the past.
- 4.8 Aside from its unusual and narrative form, T16 is relatively large for the species. Its largest individual stem is 560mm in diameter at 1.5m. For these reasons, and also because of its function for screening, it is considered to be the most individually valuable tree on the site.

Western boundary trees

- 4.9 The embankment that descends towards Station Road is covered with woody vegetation with the exception of a few patches of acid grassland, heath and ruderal herb species (see Ecology Report for details).
- 4.10 Towards the northern end of the boundary, T2, T3, T4 and T17 (silver birch, sycamore, ash and hawthorn respectively) surround an entrance point to the site close to the northern end of a low retaining stone wall. All trees are small and have low value. They make some contribution to the screening and appearance of the highway corridor but are individually unremarkable and could be replaced.
- 4.11 Groups G2 and G8 comprise small trees which form a dense group or hedge along the embankment. Hawthorn, Buddleia, elder, rosehip, cotoneaster and English oak are the dominant species, with a slightly larger oak at the southern end of the boundary being recorded separately as T13. They have some value for habitat and also contribute collectively to the appearance of the highway corridor. However, all trees are individually unremarkable and many are young. Whilst it is recommended that a green frontage and screen is maintained along this boundary, there is nothing particular to the existing trees which requires they provide this function.
- 4.12 Occasional larger trees at the top of the bank augment the boundary belt. Trees T5, T9 and T10 are basally multi-stemmed ash and goat willow. None has particularly good form.
- 4.13 Tree and group locations, their quality categories and canopy spreads are shown on Drawing 1.

Tree Quality Categorisation

- 4.14 Under *BS 5837:2012 Trees in relation to design, demolition and construction – Recommendations* trees and groups are objectively assigned a quality category designed to quantify their value within any future development. Table 1 presents a summary of the categories presented in the British Standard. The full table has been reproduced at Appendix 2.

Table 1: Summary of BS 5837 tree quality categorisation criteria

Category A	Trees of high value including those that are particularly good examples of their species and/or those that have visual importance or significant conservation or other value
Category B	Trees of moderate value including those that do not qualify as Category A due to impaired condition and/or those that collectively have higher value than they would as individuals; also trees with material conservation or other value
Category C	Trees of low value including those with very limited merit or impaired condition; trees offering transient or temporary landscape benefits
Category U	Trees with irremediable defects and anticipated early loss due to collapse; dead trees or those in immediate decline and those with infectious pathogens that threaten other trees

5.0 IMPACTS OF THE PROPOSED DEVELOPMENT

5.1 Table 2 lists the number and quality of trees that will require removal in order to facilitate the development proposals and those that can be retained. This is the result of an assessment based on the proposed site plan and discussions with the client regarding their application strategy.

Table 2: Arboricultural implications of the proposed development

	Tree Quality Category			
	A	B	C	U
Trees, groups and hedges that can be retained	T16	T1	T4, T8, T13 T17 G2, (majority), G6 (part of) G8 (half off)	-
Trees, groups and hedges that require removal to facilitate development	-	G4, G5	T2, T3, T5, T9, T10, G2 (part of) G3, G6 (majority) G8 (half of)	-
Trees located on third party land	-	T14, T15, G7	-	-

See Appendix 1, Arboricultural Data Sheets for subcategories

5.2 5 individual trees, 3 tree groups and parts of a further 3 groups would be removed to facilitate the development proposals. The majority of these are low value or of a young age and individually have little arboricultural value. It is therefore considered that replacement planting can mitigate for their loss.

- 5.3 The removal of moderate value trees within G4 and G5 will require an increased level of mitigation. The main impact will be the loss of large amounts of tree groups and the benefits these provide for wildlife and habitat. Therefore a higher ratio of replacement tree planting that can provide similar benefits should be implemented.
- 5.4 Trees T2 and T3 although not directly impacted by the development will need to be removed to provide adequate visibility splay for the proposed access.
- 5.5 Trees T15 and T16 will require pruning prior to the commencement of the development to avoid any damage to branches during construction.
- 5.6 Fencing to protect the retained trees will be necessary. This will reduce the useable area for works and storage of materials during development.
- 5.7 Where planning permission is granted, the retention schedule shown in Table 2 and Drawing 2 would normally form a part of that permission. Any change to this schedule would therefore be likely to require an application to vary the consent.

6.0 TREE PROTECTION REQUIREMENTS

Root Protection Areas

- 6.1 As per *BS 5837:2012*, the **Root Protection Area (RPA)** is calculated using each tree's diameter at 1.5 metres (refer to Appendix 1) and represents the minimum area around each tree that must be left undisturbed to ensure their survival.
- 6.2 Tree roots typically spread two times the width of the crown, although this figure may be significantly increased for certain species and where specific ground conditions are present. The majority of tree roots are found in the top 600 mm of soil and most of the fine roots that absorb water and nutrients are found in the top 100 mm.
- 6.3 The morphology of roots is influenced by past and present site conditions (the presence of roads, structures and underground services), soil type, topography and drainage. This means that a tree's roots may not be uniform in their extent and the **RPA** may not be a circular area centred on the tree stem.
- 6.4 On this site the majority of trees are growing in relatively homogeneous material. Those growing on steep slopes at the western and north-western boundaries are likely to have developed a root architecture that is biased towards the uphill side (generally towards the site interior). This effect will be compounded in the case of trees at or close to the kerb edge or the low retaining wall along Station Road, which will limit root extension towards the west. Roots are unlikely to be absent in all these areas but where unfavourable conditions exist, growth will certainly be impeded.
- 6.5 The **RPA** has been adjusted or offset to most accurately represent the likely spread of roots for each individual tree (refer to Drawing 1).

Protective Fencing and Exclusion Zones

- 6.6 Temporary protective barrier fencing will be required to demarcate a **Construction Exclusion Zone (CEZ)** around retained trees. This must be put in place prior to the commencement of any development works, including bringing machinery or materials onto site, the erection of site huts, changes in ground level or stoning up for site access.
- 6.7 The **CEZ** acts to protect both tree roots and branches and has been extended to incorporate canopy spread where appropriate.
- 6.8 Protective fencing alignment is shown on Drawing 2 and assumes that all trees identified for removal have been felled prior to installation.
- 6.9 The fencing must be fixed into the ground to withstand accidental impact from machinery and to ensure that a sufficient protective area is maintained. Details of recommended protective fencing are shown on Drawing 3.
- 6.10 A weatherproof notice stating 'Construction Exclusion Zone – Keep Out' should be fixed to each fencing panel.
- 6.11 Any alteration to the fencing alignment to allow for approved activities will be made in agreement with the council's Arboricultural Officer.
- 6.12 The protective fencing must not be removed until the physical construction phase has been completed and all vehicles have been removed from site, to the satisfaction of the council's Arboricultural Officer.

Ground Contamination

- 6.13 Storage areas for liquids such as fuels, oil or paint should not be located within 10m of any trees on or within proximity to the site due to the risk of soil contamination caused by accidental spillage.
- 6.14 Particular care must be taken when working on or close to sloping ground to avoid unintentional runoff into the rooting area of retained trees.

Underground Utility Issues

- 6.15 No utility drawings were provided and no assessment has been made of the juxtaposition of tree roots and the likely location of new services. It has been presumed for the purposes of this report that all utilities will be installed outside of the **Construction Exclusion Zone** shown on Drawing 2.
- 6.16 Where the installation of services within the **Construction Exclusion Zone** of retained trees is unavoidable, appropriate work methods will be required to ensure the safe long-term survival of those trees. This process will require additional consultation with a qualified Arboricultural Consultant and is likely to be more expensive than conventional trench installation.

Ground Level Changes

- 6.17 A rise or reduction in soil level can have major implications on the longevity and health of the trees. Minor changes (up to 100mm) can be tolerated in some cases but is heavily dependent on tree species, condition and growing environment.
- 6.18 Existing ground levels within the **Construction Exclusion Zone** should be respected. Certain assumptions have been made as to the ability to deliver the nominated scheme without recourse to cut or fill within any Construction Exclusion Zone. The advice of a qualified Arboricultural Consultant should be sought if level changes are required in these areas or if future design changes necessitate such works.

Drainage & Storm Water Run-off Issues

- 6.19 Drainage and storm water run-off requires due consideration and construction requirements (e.g. permeable surfacing) to prevent excessive and/or polluted run-off into the rooting area of trees to be retained.
- 6.20 No existing water bodies or hydrology patterns were observed that are essential for the survival of existing trees.
- 6.21 The development will increase the amount of hard surfacing across the site and therefore change the flow of surface water. It will be important to ensure that excessive run-off and associated erosion or water-logging can be prevented along the western and north-western boundaries. It is likely that any approved drainage scheme will accomplish these objectives in pursuit of wider objectives relating to the containment of storm water and the prevention of run-off onto adjacent housing or the highway.

7.0 ARBORICULTURAL RECOMMENDATIONS

Tree Work

- 7.1 In addition to the tree removals required to facilitate the development proposals, T1 should be crown raised and the epicormic growth at base pruned to allow visibility splay clearance for the site entrance.
- 7.2 The pruning of T5 and T16 will be required to facilitate the development. A definite tree works schedule should be provided as part of the AMS.
- 7.3 All tree surgery work should be carried out by a qualified contractor in accordance with *BS 3998:2010 Tree work – Recommendations*.

Arboricultural Method Statement

- 7.4 An **Arboricultural Method Statement (AMS)** will be required where construction activities are proposed within the Root Protection Areas (RPA) of retained trees. Under the current proposals this applies to trees T1, T5 and T16.

- 7.5 The purpose of an **AMS** is to demonstrate that the proposed operations can be undertaken with minimal risk of adverse impact on trees to be retained. It will set the parameters within which construction will need to be undertaken and will guide the actions of site operatives.
- 7.6 Construction methods presented in an **AMS** are likely to be the result of collaboration between an Arboricultural Consultant and other project specialists. This process may result in the use of un-conventional building techniques and those allowing more control over soil and root disturbance.

Mitigation for the removal of trees

- 7.7 5 individual trees, 3 tree groups and parts of a further 3 groups require removal to facilitate the development proposals. Mitigation for their loss and associated habitat may be required in the form of replacement tree planting.
- 7.8 Space for replacement planting will be limited on this site, however new trees such as English oak (*Quercus robur*), hawthorn (*Crataegus monogyna*) and field maple (*Acer campestre*) should be planted in any gaps along the road frontage, avoiding the acid grassland area – see ecology report.
- 7.9 Small garden trees such as birch (*Betula pendula*), hazel (*Corylus avellana* “Zellernus”) or apple (*Malus* sp.) should be incorporated into the rear gardens of properties to provide seasonal colour, interest and wildlife values.
- 7.10 Mixed native hedgerow along the northern and southern boundaries will provide rear garden boundaries and further wildlife benefits.
- 7.11 Aftercare is vital to the survival of newly planted trees. Provision should be made for a minimum of two years maintenance of newly planted trees and include watering, formative pruning and the checking of tree ties and stakes.
- 7.12 The National Planning Policy Framework (NPPF) is a material consideration in the planning process and promotes a presumption in favour of sustainable development. In terms of the natural environment, development should minimise impacts on biodiversity and provide a net gain in biodiversity where possible.
- 7.13 In respect of trees, a sustainable development will be one whereby the total number, value or function provided by trees is maintained or increased or where the long-term prospects of the existing tree stock can be substantially improved. Net gains in biodiversity may be demonstrated where the number of tree species, variety of tree ages or range of niche habitats can be increased. Native, old, large or dead trees are likely to have a relatively significant impact on a scheme's environmental credentials, as will the connectivity of trees, hedges and woodland.
- 7.14 It is the recommendation of this report that mitigation in the form of tree planting has the potential to result in a small short term net loss of long-term tree cover (estimated at 10 years post-construction). This is wholly dependent on an appropriate planting scheme species selection, tree quality and high establishment rates. See 7.8 – 7.11
- 7.15 The extent of mitigation planting will ultimately be determined in agreement with Barnsley Metropolitan Borough Council.

Post Construction Tree Care

- 7.16 Hazard recommendations are based on observations at the time of survey. Trees are dynamic living organisms whose structure is constantly changing. Even those in good condition can suffer from damage or stress. Following site development, regular (annual or biennial) inspections of all retained trees should be undertaken by a qualified Arboricultural Consultant.

8.0 SUMMARY

- 8.1 Based on an objective assessment made in accordance with *BS 5837:2012 Trees in relation to design, demolition and construction – Recommendations*, there are 1 Category A, 6 Category B and 13 Category C trees and groups on or within influencing distance of the site.
- 8.2 5 individual trees, 3 tree groups and parts of a further 3 groups require removal to facilitate the development proposals. The majority of these are low value or of a young age and individually have little arboricultural value, refer to Table 2.
- 8.3 Barnsley Metropolitan Borough Council have been contacted regarding confirmation of any trees on or immediately adjacent to the site that are subject to Tree Preservation Orders or Conservation Area status. At the time of completion of this report no response has been received.
- 8.4 Trees in group G4 were noted as having features of a size and condition desirable to bats. This should be confirmed by a suitably experienced ecologist.
- 8.5 Protective barrier fencing will be required to demarcate a Construction Exclusion Zone (**CEZ**) around retained trees prior to the commencement of development. Fencing alignment is shown on Drawing 2 and details of the recommended fencing are shown on Drawing 3. This will restrict movements on the site which should be considered early in the construction process.
- 8.6 An **Arboricultural Method Statement (AMS)** will be required where construction activities are proposed within the Root Protection Areas (RPA) of retained trees. Under the current proposals this applies to trees T1, T5 and T16.
- 8.7 Mitigation for the loss of trees, should it be a requirement, is recommended to take the form of replacement planting.
- 8.8 It is the recommendation of this report that mitigation in the form of tree planning has the potential to result in a small short term net loss of long-term tree cover (estimated at 10 years post-construction). This is wholly dependent on an appropriate planting scheme species selection, tree quality and high establishment rates. See 7.8 – 7.11

APPENDIX 1

ARBORICULTURAL SURVEY DATA SHEETS

APPENDIX 1: Arboricultural Survey Data Sheets



Surveyor **TDP**
 Date **8th October 2013**
 Town **Royston**
 Site **Station Road**
 Dwg Ref **D4186.001**

NB - Trees marked 'NOT PRESENT' were surveyed on 08.11.2010 and no longer present during this subsequent survey 08.10.13. The original survey data is presented unamended; no assessment of the timing, manner or reason for removal is made.

Ref	Species	Height	Stem Dia.	No. of stems/ individuals	Crown Spread North	Crown Spread South	Crown Spread East	Crown Spread West	Height of Lowest Branch	Direction of Lowest Branch	Maturity	Condition	Comments on form, condition, health and significant defects	BS5837 Tree Quality Assess.	Radius of RPA guide circle	BS5837 RPA Area	Management Recommendations	Estimated Remaining Contribution	TPO
		(m)	(mm)	arising below 1.5m	(m)	(m)	(m)	(m)	(m)	(m)	Young, Middle Age, Mature	Good, Fair, Poor, Veteran		A,B,C,R (1,2,3)	(m)	(m2)		Long, Medium, Short	(*)
Trees																			
T1	Sycamore	10.0	1039.2	12.0	8.0	6.0	6.0	7.0	0.0		Middle Age	Good	A collection of stems forming a single sinuous crown; all stems ivy clad; screens adjacent property and prominent from roadside	B,1,2	12.5	488.6	Crown raise and prune epicormic growth at base to allow visibility splay clearance for site entrance	Long	
T2	Silver birch	6.0	140.0	3.0	1.0	3.0	1.0	1.0	1.0	SW	Middle Age	Good	Vigorous, self sown specimen; basally multi-stemmed; former loss of central leader with side branch having become dominant from acceptable union	C,1,2	1.7	8.9	Remove, within visibility splay at site entrance	Long	
T3	Sycamore	8.0	340.0	4.0	3.5	3.5	3.0	3.0	0.0		Middle Age	Good	Shrubby form; growing adjacent to low stone retaining wall; basally multi-stemmed	C,1,2	4.1	52.3	Remove, within visibility splay at site entrance	Long	
T4	Ash	7.0	206.2	3.0	3.5	3.0	3.0	3.0	0.0		Middle Age	Good	Vigorous, self sown tree; basally trifurcate but all stems rooted individually; compression fork development at base; good balanced crown	C,1	2.5	19.2		Long	
T5	Goat willow	9.0	500.0	7.0	7.0	5.0	3.0	6.0	1.0		Mature	Fair	Wide, sprawling form due to a splay of leaning stems originating from a central decaying union; crossing stems/ branches; deadwood in crown and several small previous branch failures; some screening value	C,1	6.0	113.1	Coppice tree and plant up surrounding gaps to improve screening and habitat connections	Medium	
T6	NOT PRESENT	6.0	600.0	10.0	3.0	4.0	4.0	3.0	1.0		Mature	Fair	Goat willow with typical form for species; congested central stems	C,1	7.2	162.9		Medium	
T7	NOT PRESENT	5.0	550.0	12.0	4.0	1.0	4.0	4.0	1.0		Middle Age	Fair	Basally multi-stemmed goat willow; crown bias northward due to competition with adjacent trees; rooted on disturbed/undulating ground	C,1	6.6	136.8		Long	
T8	Elder	4.0	240.0	3.0	1.0	2.0	1.0	1.0	1.0		Middle Age	Good	Reasonable form for species; rooted on moderately steep bank approximately 1.2m from Station Road	C,1	2.9	26.1		Long	
T9	Ash	7.0	250.0	4.0	3.0	3.0	3.0	3.0	1.0	E	Middle Age	Good	Vigorous tree; multi-stemmed from base; re-sprouting from cut stump with decay pocket at points of attachment	C,1	3.0	28.3		Medium	
T10	Goat willow	7.0	489.9	6.0	2.0	2.0	2.0	1.0	1.0		Middle Age	Good	Vigorous tree; multi-stemmed from base; compression fork with evidence of fusing to reinforce union	C,1	5.9	108.6		Long	

APPENDIX 1: Arboricultural Survey Data Sheets

Ref	Species	Height	Stem Dia.	No. of stems/ individuals	Crown Spread North	Crown Spread South	Crown Spread East	Crown Spread West	Height of Lowest Branch	Direction of Lowest Branch	Maturity	Condition	Comments on form, condition, health and significant defects	BS5837 Tree Quality Assess.	Radius of RPA guide circle	BS5837 RPA Area	Management Recommendations	Estimated Remaining Contribution	TPO
		(m)	(mm)	arising below 1.5m	(m)	(m)	(m)	(m)	(m)	(m)	Young, Middle Age, Mature	Good, Fair, Poor, Veteran		A,B,C,R (1,2,3)	(m)	(m ²)		Long, Medium, Short	(*)
T11	NOT PRESENT	8.0	460.0	3.0	4.0	3.0	3.0	4.0	1.0		Middle Age	Good	Silver birch with broad form for species; all stems rooted individually but causing the development of compression forks	C,1	5.5	95.7		Long	
T12	NOT PRESENT	8.0	210.0	1.0	1.0	1.0	1.0	1.0	1.0		Middle Age	Good	Silver birch with columnar form, typical for species	C,1	2.5	20.0		Long	
T13	English oak	3.0	90.0	2.0	2.0	2.0	2.0	2.0	0.0		Young	Good	Poor potential for integration within a development due to a lack of apical dominance on such a small tree; unlikely to become a tall tree and would not take pruning well; will retain low, rounded form; however, an attractive tree without defect and in good condition	C,1,2	1.1	3.7		Long	
T14	Cypress sp.	8.0	210.0	1.0	3.0	2.5	2.5	2.5	0.0		Middle Age	Good	Typical form for species; basally multistemmed/sucker growth from roots but with one clear leader forming typical apically dominant tree; ornamental and screening value; no defects	B,1,2	2.5	20.0		Long	
T15	Sycamore	8.0	300.0	1.0	5.0	6.0	5.0	5.5	1.5	S	Middle Age	Good	Single stem and good form; on banked ground leading down to adjacent property; on third party land 1m from boundary; screening value	B,1,2	3.6	40.7		Long	
T16	Pear	10.0	1583.9	8.0	10.0	5.0	5.5	5.0	0.0	N	Mature	Good	Very large for the species; basally multistemmed with form suggesting old coppice or growth from a single large stem that has since decayed away leaving three distinct clusters of growth in an approximate ring; one cluster dominated by a single large stem and forming the principal height and canopy of the tree, one cluster multistemmed and forming lower canopy, one cluster failed at base but surviving and stable with harp regrowth to north; outward appearance of a group of trees but actually one individual; some veteran characteristics but still in good health; edible fruit	A,2,3	15.0	707.0		Long	
T17	Hawthorn	5.0	270.0	3.0	3.0	3.0	2.0	2.0	0.0		Middle Age	Good	Basally trifurcate small boundary tree	C,1,2	3.2	33.0		Long	
Groups																			
G1	NOT PRESENT	7.0	200.0								Young to Middle Age	Good	8 silver birch trees in roughly linear group; all vigorous and with typical columnar form	C,1	Refer to Drawing	n/a		Long	
G2	Hawthorn; English oak; Buddleia; elder	5.0	320.0								Middle Age	Good	Scrubby group growing on spoil material	C,1,2	Refer to Drawing	n/a		Long	

APPENDIX 1: Arboricultural Survey Data Sheets

Ref	Species	Height	Stem Dia.	No. of stems/ individuals	Crown Spread North	Crown Spread South	Crown Spread East	Crown Spread West	Height of Lowest Branch	Direction of Lowest Branch	Maturity	Condition	Comments on form, condition, health and significant defects	BS5837 Tree Quality Assess.	Radius of RPA guide circle	BS5837 RPA Area	Management Recommendations	Estimated Remaining Contribution	TPO
		(m)	(mm)	arising below 1.5m	(m)	(m)	(m)	(m)	(m)	(m)	Young, Middle Age, Mature	Good, Fair, Poor, Veteran		A,B,C,R (1,2,3)	(m)	(m2)		Long, Medium, Short	(*)
G3	Silver birch	5.0	264.6	7.0							Young to Middle Age	Good	Group of vigorous self-set trees	C,2	Refer to Drawing	n/a		Long	
G4	Hawthorn; elder; field maple	6.0	330.0								Mature	Good	Lapsed hedgerow forming a row of fully grown trees; demarcates the line of an old field boundary; one dead tree (small)	B,2,3	Refer to Drawing	n/a		Long	
G5	Hawthorn, privet; sycamore	8.0	to 350	10+					0.0		Middle Age	Good	Ivy-clad middle aged sycamore and hawthorn trees with smaller privet and hawthorn forming understorey; on lower ground towards boundary; screening adjacent property; large compost heap within area, presumably from adjacent property	B,2	Refer to Drawing	n/a		Long	
G6	Damson; Buddleia	4.0	to 100	10+					0.0		Young to Middle Age	Fair	Thicket of dense multistemmed bushes and small trees; edible fruits; good screening and habitat value; some failed or leaning stems and some suppressed individuals due to density of group and overhanging G7 but none hazardous, due to small size	C,2,3	Refer to Drawing	n/a		Long	
G7	Hawthorn	7.0	to 450	10+					0.0		Middle Age to Mature	Good	Boundary row of trees forming a screen; some individuals topped or heavily pruned and re-sprouting from cut stumps; minor stem cavities but otherwise in good condition and appropriate to the location	B,2	Refer to Drawing	n/a		Long	
G8	Elder; hawthorn; damson; cotoneaster; rosehip; English oak	5.0	to 150	10+					0.0		Young to Middle Age	Good	Screening value along main road; vehicle 'pruned' on roadside; planting extending up bank, possibly planted when rising main was laid beneath site; good habitat links and contributes to greening of highway corridor	C,1,2,3	Refer to Drawing	n/a	Eradicate invasive cotoneaster; protect acid grassland (see Ecology Report for details)	Long	

APPENDIX 2

SURVEY METHOD

APPENDIX 2: SURVEY METHOD

The survey of trees is conducted from ground level only. The nature of the soils on site is not assessed.

Trees are dynamic living organisms with a constantly changing structure; even trees in good condition can suffer from damage or stress. The information recorded is presented as being correct at the time of survey.

The following features of each tree, group of trees or wood may have been recorded in the Arboricultural Survey Data Sheets at Appendix 1.

Species	The common name is given. The Latin name may also be given if further clarification is required.	
Height	Top height of tree recorded in metres.	
Stem Diameter	For single-stemmed trees the measurement is taken at 1.5 metres above ground level and recorded in millimetres. For multi-stemmed trees an average all stems measured at 1.5m above ground level is used. For tree groups a range from minimum to maximum diameters is provided based on measurements taken using one of the aforementioned methods.	
No. of Stems	A count of stems arising below a height of 1.5 metres.	
Crown Spread	The N, S, E and W branch spreads are recorded in metres to provide a representative crown shape.	
Height of Lowest Branch	Crown clearance above ground level recorded in metres.	
Direction of Lowest Branch	The direction of growth of the first significant branch from the point of attachment.	
Maturity	Young	Trees that can reasonably be relocated or replaced like for like, without undue cost;
	Middle Age	Trees in the established growth stage of their life with the potential to continue increasing in size;
	Mature	Trees that have reached their ultimate size, given their location and surroundings;
Condition	Good, Fair, Poor. An overall assessment of a tree's physiological and structural state in which factors that may increase its susceptibility to the effects of development are taken into account. Veteran. Trees that are in such a condition as to significantly increase their biological, cultural or aesthetic value. This is characteristic of, but not exclusive to, individuals surviving beyond the typical age range for the species concerned.	
Comments	A brief evaluation and description of the tree with comments on form, vitality, health and any significant defects or symptoms of ill-health.	

BS 5837 Tree Quality Assessment

The tree quality assessment is based on Table 1 of BS 5837:2012 (See below). Four categories (A, B, C and U) are used to denote tree quality (A= High, B = Moderate, C = Low, U= Unsuitable for retention). Subcategories (1-3) denote the specific function value of the trees and the reasoning behind the allocation of a specific category (the subcategories may be used in combination but do not accumulate collective weight).

Root Protection Area (RPA)

The RPA is allocated to ensure that a sufficient area is left undisturbed during development. It is provided as an area (m²) and as the radius of a circle (m) typically plotted from the centre of the stem.

The RPA is calculated using a mathematical equation included in BS 5837:2012 (Section 4.6 and Table D.1) and is based on a tree's stem diameter. In some cases the RPA may need to be adapted to best reflect the likely area and position of roots required to ensure survival; this may be based on criteria such as the tree's condition, species, crown spread and any barriers to growth. Any alteration must be justifiable but is made at the Arboricultural Consultants discretion.

Recommendations

Recommendations for arboricultural works, etc. are based on the **current** land use, and take into account the tree or group attributes without bias to the proposed development.

Estimated Remaining Contribution

An estimation of the life expectancy as healthy functioning tree. This will be influenced by species and the condition of the tree at the time of survey.

Long	> 40 years
Medium	20 – 40 years
Short	less than 20 years

APPENDIX 2: SURVEY METHOD

Table 1 Cascade chart for tree quality assessment

Category and definition	Criteria (including subcategories where appropriate)			Identification on plan
Trees unsuitable for retention (see Note)				
Category U Those in such a condition that they cannot realistically be retained as living trees in the context of the current land use for longer than 10 years	<ul style="list-style-type: none"> Trees that have a serious, irremediable, structural defect, such that their early loss is expected due to collapse, including those that will become unviable after removal of other category U trees (e.g. where, for whatever reason, the loss of companion shelter cannot be mitigated by pruning) Trees that are dead or are showing signs of significant, immediate, and irreversible overall decline Trees infected with pathogens of significance to the health and/or safety of other trees nearby, or very low quality trees suppressing adjacent trees of better quality <p><i>NOTE Category U trees can have existing or potential conservation value which it might be desirable to preserve; see 4.5.7.</i></p>			See Table 2
	1 Mainly arboricultural qualities	2 Mainly landscape qualities	3 Mainly cultural values, including conservation	
Trees to be considered for retention				
Category A Trees of high quality with an estimated remaining life expectancy of at least 40 years	Trees that are particularly good examples of their species, especially if rare or unusual; or those that are essential components of groups or formal or semi-formal arboricultural features (e.g. the dominant and/or principal trees within an avenue)	Trees, groups or woodlands of particular visual importance as arboricultural and/or landscape features	Trees, groups or woodlands of significant conservation, historical, commemorative or other value (e.g. veteran trees or wood-pasture)	See Table 2
Category B Trees of moderate quality with an estimated remaining life expectancy of at least 20 years	Trees that might be included in category A, but are downgraded because of impaired condition (e.g. presence of significant though remediable defects, including unsympathetic past management and storm damage), such that they are unlikely to be suitable for retention for beyond 40 years; or trees lacking the special quality necessary to merit the category A designation	Trees present in numbers, usually growing as groups or woodlands, such that they attract a higher collective rating than they might as individuals; or trees occurring as collectives but situated so as to make little visual contribution to the wider locality	Trees with material conservation or other cultural value	See Table 2
Category C Trees of low quality with an estimated remaining life expectancy of at least 10 years, or young trees with a stem diameter below 150 mm	Unremarkable trees of very limited merit or such impaired condition that they do not qualify in higher categories	Trees present in groups or woodlands, but without this conferring on them significantly greater collective landscape value; and/or trees offering low or only temporary/transient landscape benefits	Trees with no material conservation or other cultural value	See Table 2

British Standards Institute (2012) BS5837:2012 Trees in relation to design, demolition and construction – Recommendations.
p.9

NOTES:

All young trees are assessed as quality category 'C' but this does not preclude their retention within a development.

For hedges the height, canopy spread and number of stems is recorded but they are not assigned a quality category.

DRAWING 1

TREE CONSTRAINTS PLAN

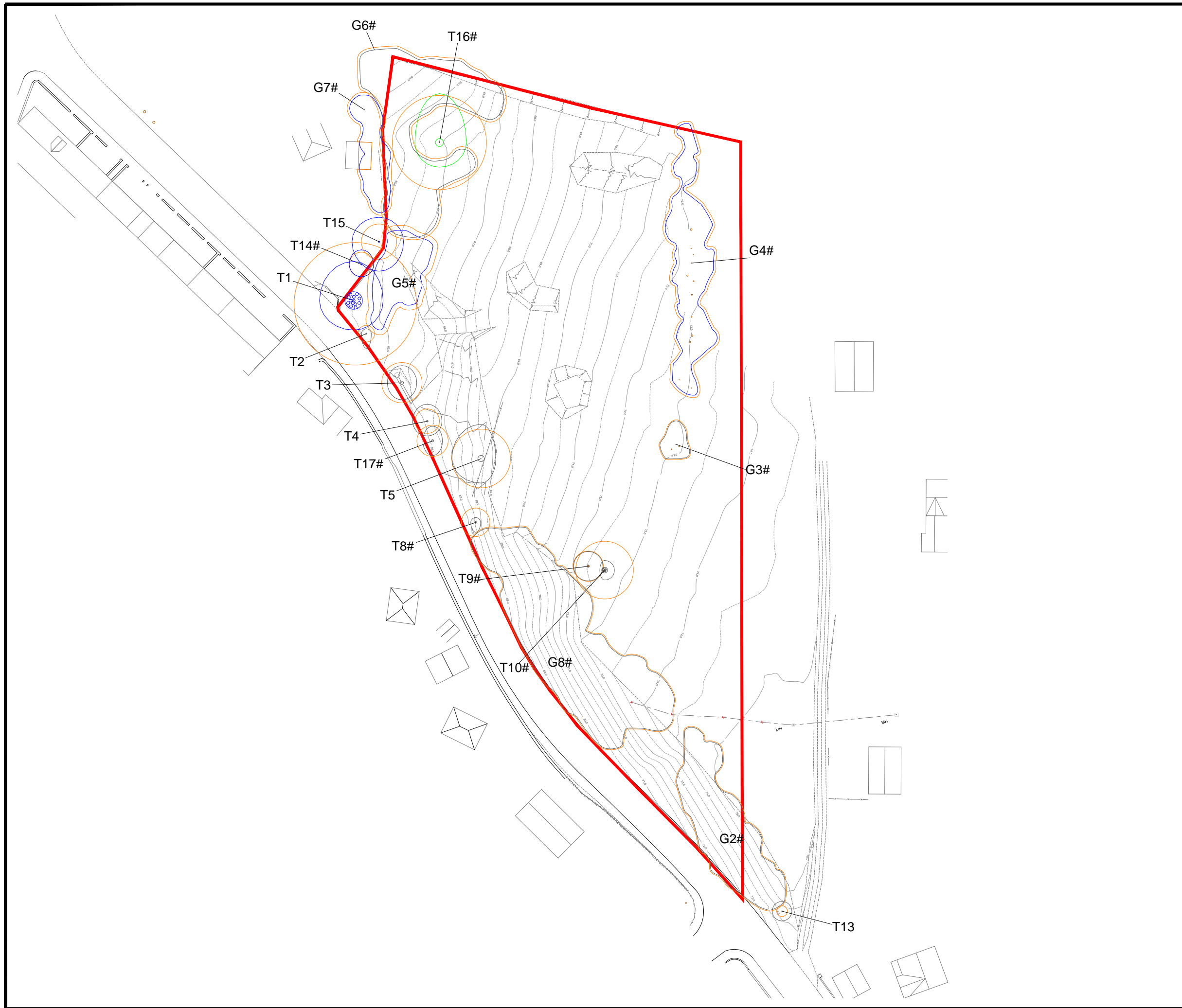

KEY

[This drawing must be reproduced in colour]

- T1 Individual trees
- G1 Groups of trees
- Root Protection Area (RPA)
- Survey Boundary
- # Approximate location (Feature not shown on topo)
- * Statutory Protection (TPO, Conservation Area, Important Hedgerow etc.)

Tree Categorisation

(Tree quality assessment based on BS 5837:2012 Trees in relation to design, demolition and construction - Recommendations)

- Category A (High quality)
- Category B (Moderate quality)
- Category C (Low quality)
- Category U (Unsuitable for retention)

NOTE: This drawing should be read in conjunction with the respective Arboricultural Data Sheets (Appendix 1).



Rev	Description	Drawn	Approved	Date

	Genesis Centre Birchwood Science Park Warrington WA3 7BH Tel 01925 844004 Fax 01925 844002 e-mail tep@tep.uk.com

Project

Station Road, Royston
Arboricultural Impact Assessment

Title

Tree Constraints Plan
[EXISTING]

Drwg No **D4186.001**

Scale 1:750 @ A3	Date 05/12/13
-------------------------	----------------------

Drawn TDP	Checked JGS	Approved JGS
------------------	--------------------	---------------------

DRAWING 2

TREE REMOVAL PLAN

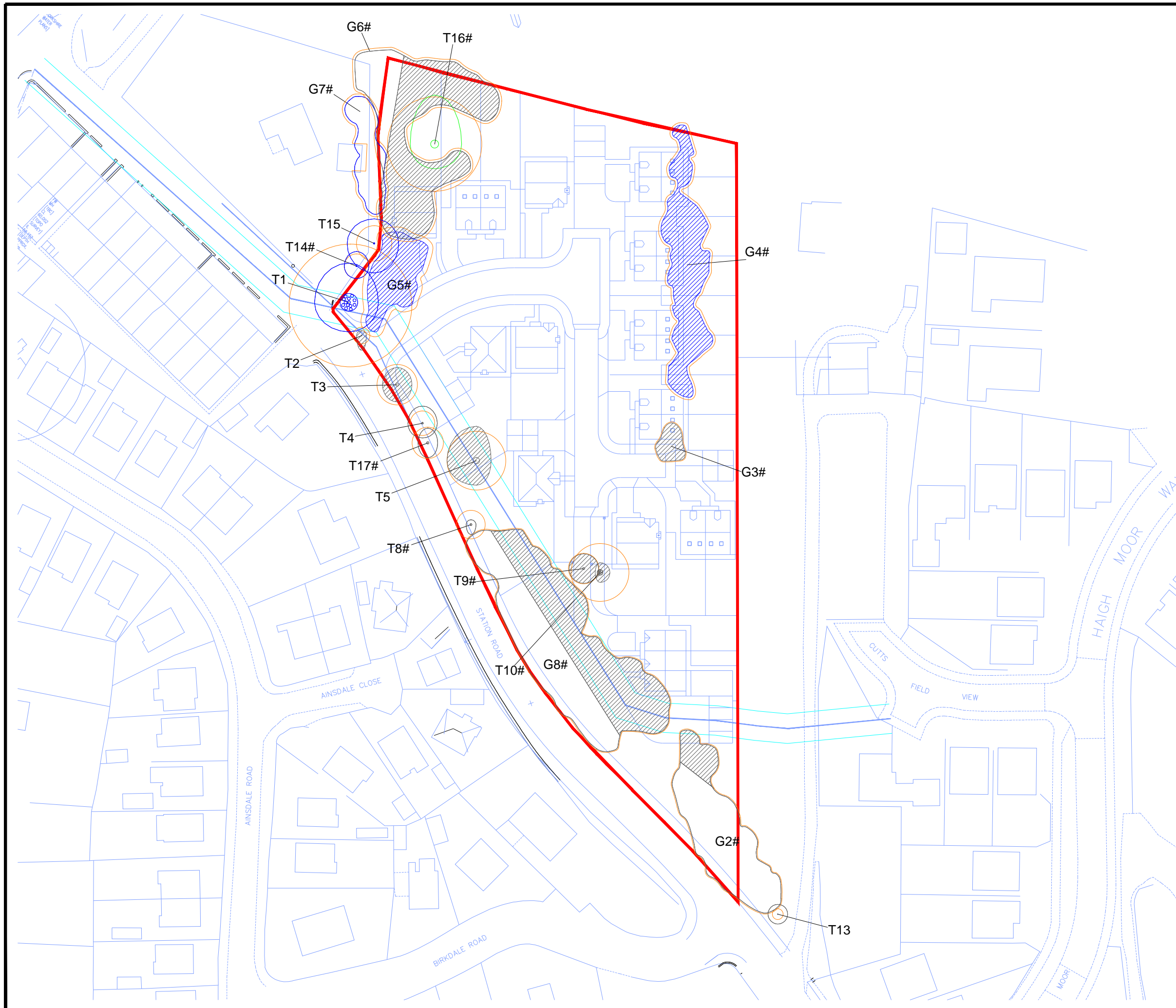

KEY

[This drawing must be reproduced in colour]

- T1 Individual trees
- G1 Groups of trees
- Survey Boundary
- # Approximate location (Feature not shown on topo)
- * Statutory Protection (TPO, Conservation Area, Important Hedgerow etc.)
- Tree Protection Fencing (Must be installed prior to works commencement)
- Special Mitigation Construction (Requires Arboricultural Method Statement)
- Temporary Ground Protection (Requires Arboricultural Method Statement)

Trees to be retained
 (Tree quality assessment based on BS 5837:2012 Trees in relation to design, demolition and construction - Recommendations)

- Category A (High quality)
- Category B (Moderate quality)
- Category C (Low quality)
- Category U (Trees with existing or potential conservation value)

Trees to be removed
 (Tree quality assessment based on BS 5837:2012 Trees in relation to design, demolition and construction - Recommendations)

- Category A (High quality)
- Category B (Moderate quality)
- Category C (Low quality)
- Category U (Unsuitable for retention)

NOTE: This drawing should be read in conjunction with the respective Arboricultural Data Sheets (Appendix 1).



Rev	Description	Drawn	Approved	Date

	Genesis Centre Birchwood Science Park Warrington WA3 7BH Tel 01925 844004 Fax 01925 844002 e-mail tep@tep.uk.com

Project
 Station Road, Royston
 Arboricultural Impact Assessment

Title
 Tree Removal Plan
 [PROPOSED]

Drwg No	D4186.002	
Scale	1:750 @ A3	Date 20/11/13
Drawn	Checked	Approved
KJT	TDP	JGS

DRAWING 3

TREE PROTECTION PLAN

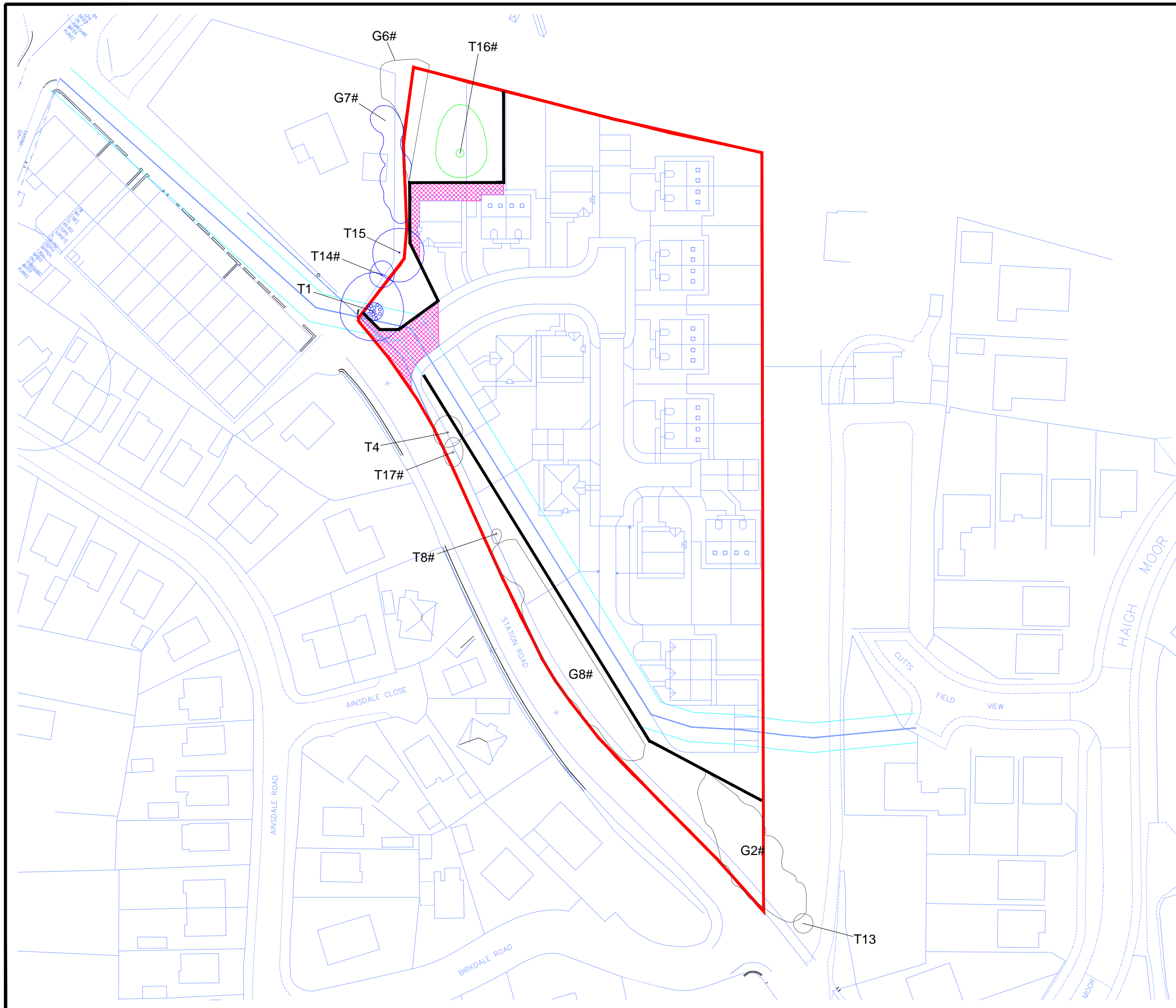

KEY

[This drawing must be reproduced in colour]

- T1 Individual trees
- G1 Groups of trees
- Survey Boundary
- Approximate location (Feature not shown on topo)
- Statutory Protection (TPO, Conservation Area, Important Hedgerow etc.)
- Tree Protection Fencing (Must be installed prior to works commencement)
- Special Mitigation Construction (Requires Arboricultural Method Statement)
- Temporary Ground Protection (Requires Arboricultural Method Statement)

Trees to be retained

(Tree quality assessment based on BS 5837:2012 Trees in relation to design, demolition and construction - Recommendations)

- Category A (High quality)
- Category B (Moderate quality)
- Category C (Low quality)
- Category U (Trees with existing or potential conservation value)

Trees to be removed

(Tree quality assessment based on BS 5837:2012 Trees in relation to design, demolition and construction - Recommendations)

- Category A (High quality)
- Category B (Moderate quality)
- Category C (Low quality)
- Category U (Unsuitable for retention)

NOTE: This drawing should be read in conjunction with the respective Arboricultural Data Sheets (Appendix 1).



Rev	Description	Drawn	Approved	Date

	Genesis Centre Birchwood Science Park Warrington WA3 7BH Tel 01925 844004 Fax 01925 844002 e-mail tep@tep.uk.com
	Project Station Road, Royston Arboricultural Impact Assessment

Title Tree Protection Plan [PROPOSED]
--

Drwg No D4186.003

Scale 1:750 @ A3	Date 20/11/13
Drawn KJT	Checked TDP
Approved JGS	

DRAWING 4

TEMPORARY TREE PROTECTION FENCING

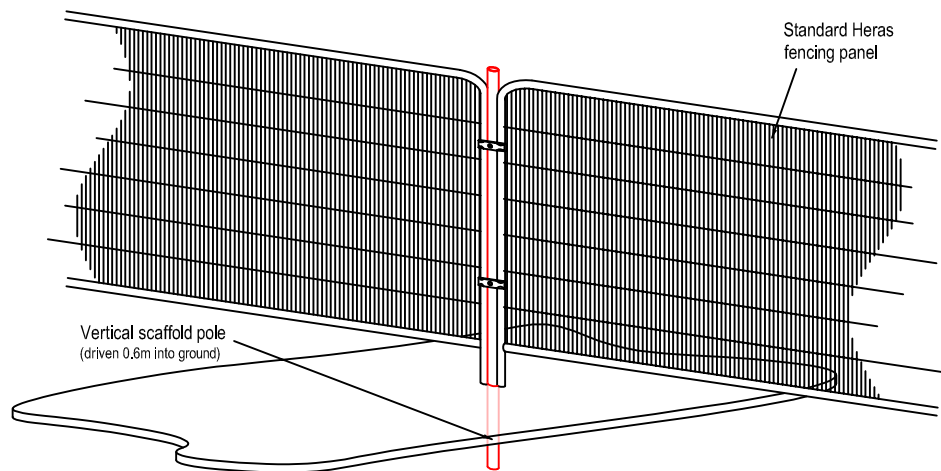

Type A Tree Protection Fencing: for use as standard
(see Tree Protection Plan for layout)

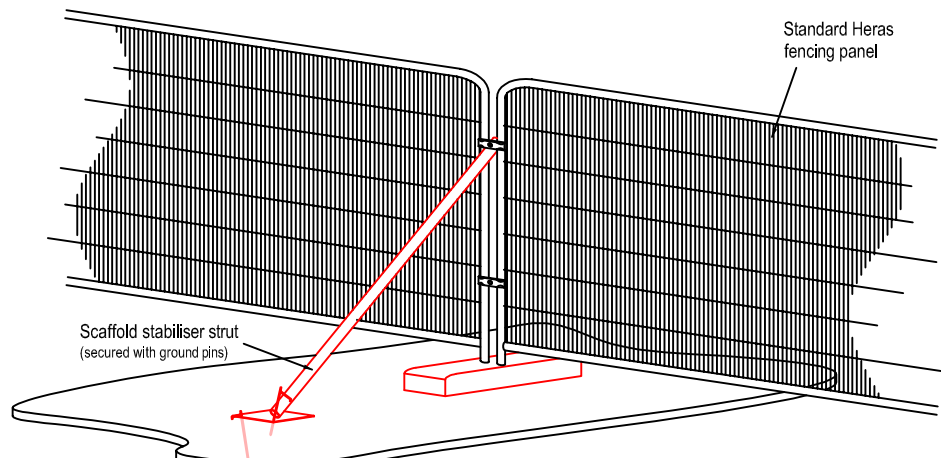

Type B Tree Protection Fencing: for use as directed
(e.g. where Type A would cause unacceptable damage to roots or underground services)

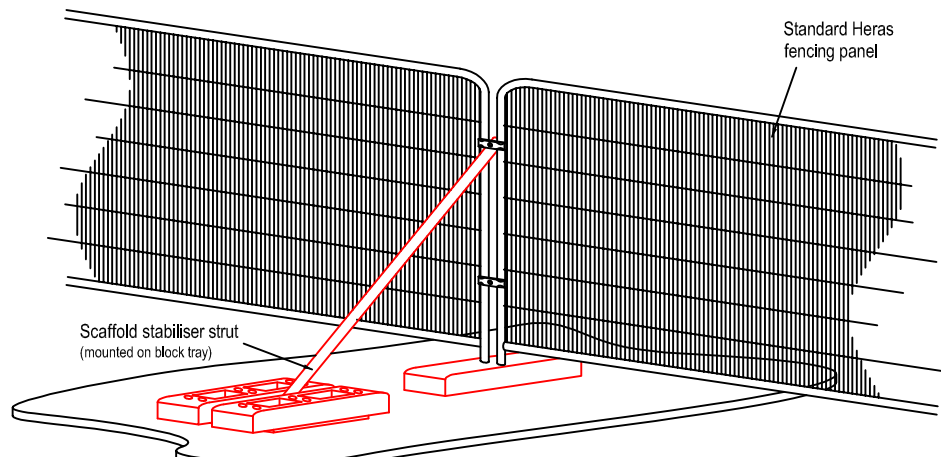

Type C Tree Protection Fencing: for use as directed
(e.g. on hard surfaces)

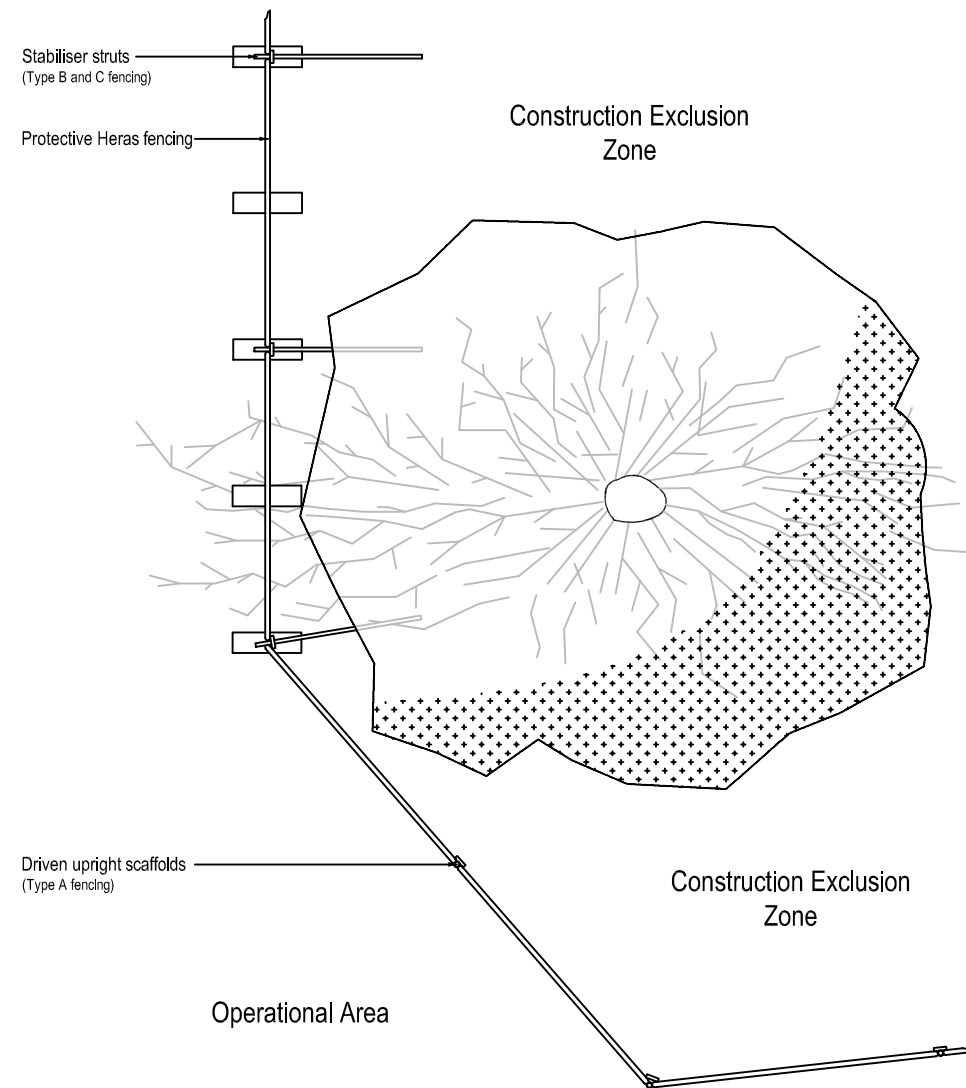
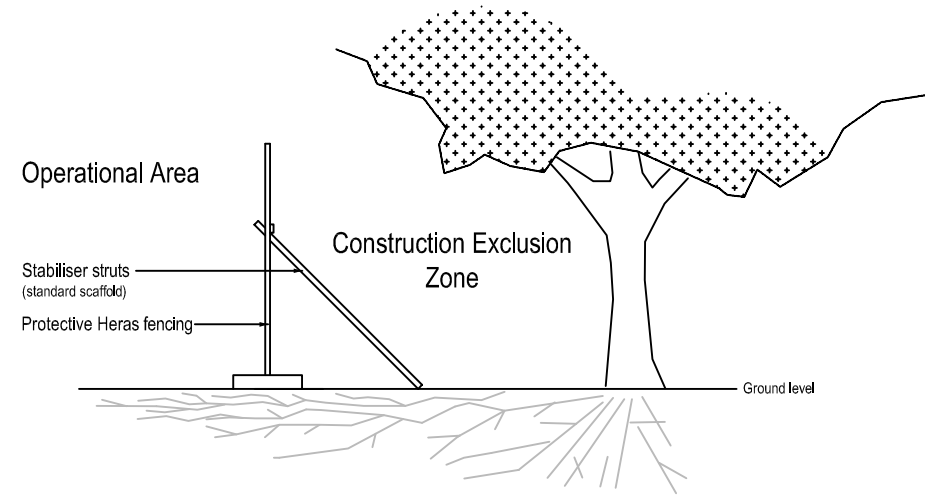

PROTECTIVE FENCING. THIS FENCING MUST BE MAINTAINED IN ACCORDANCE WITH THE APPROVED PLANS AND DRAWINGS FOR THIS DEVELOPMENT.

TREE PROTECTION AREA KEEP OUT!
(TOWN & COUNTRY PLANNING ACT 1990)
TREES ENCLOSED BY THIS FENCE ARE PROTECTED BY PLANNING CONDITIONS AND/OR ARE THE SUBJECTS OF A TREE PRESERVATION ORDER.
CONTRAVENTION OF A TREE PRESERVATION ORDER MAY LEAD TO CRIMINAL PROSECUTION
ANY INCURSION INTO THE PROTECTED AREA MUST BE WITH THE WRITTEN PERMISSION OF THE LOCAL PLANNING AUTHORITY

Tree Protection Notice to be attached to fencing 1.5m from the ground, facing out of the Construction Exclusion Zone and located at regular intervals along the fence line.

The notice must be at least A4 in size

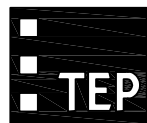
Rev	Description	Drawn	Approved	Date
 Genesis Centre Birchwood Science Park Warrington WA3 7BH Tel 01925 844004 Fax 01925 844002 e-mail tep@tep.uk.com				
Project				
TEP Standard Detail				
Title				
Temporary Tree Protection Fencing (Detail for tree protection around Construction Exclusion Zones)				
Drwg No D.TREE_FENCING.001				
Scale NTS @ A3			Date 30/04/12	
Drawn TDP	Checked ROS	Approved JGS		