

Carefully verify the Layout proposal in every detail and kindly submit a confirmation or a request for modification

Customer signature: _____

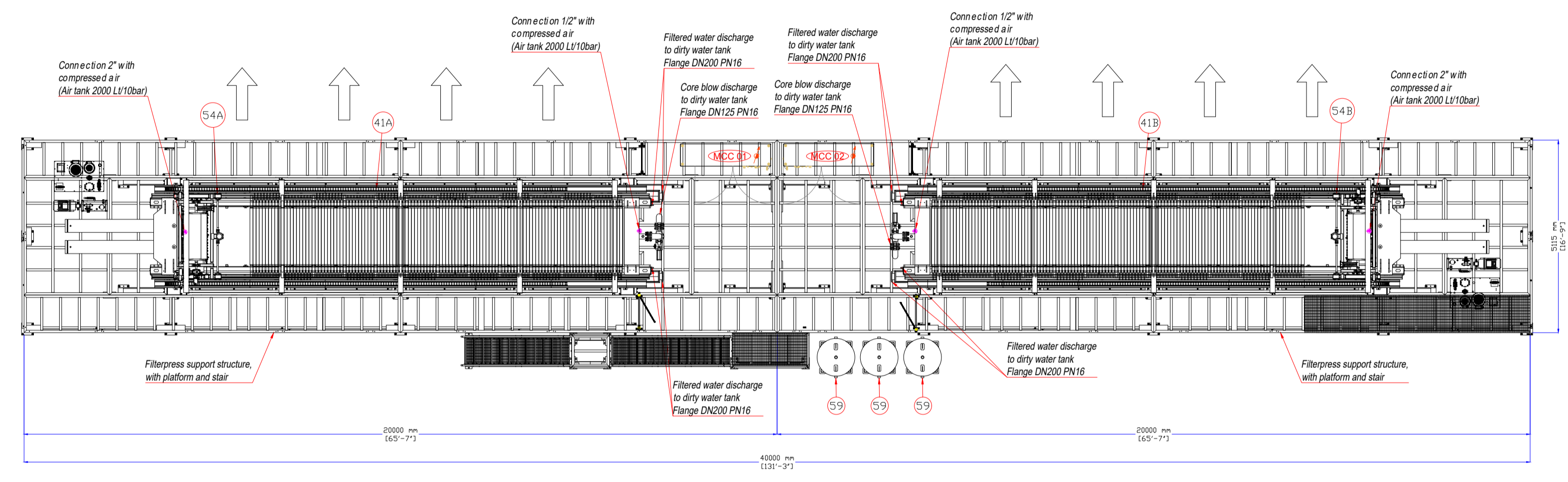
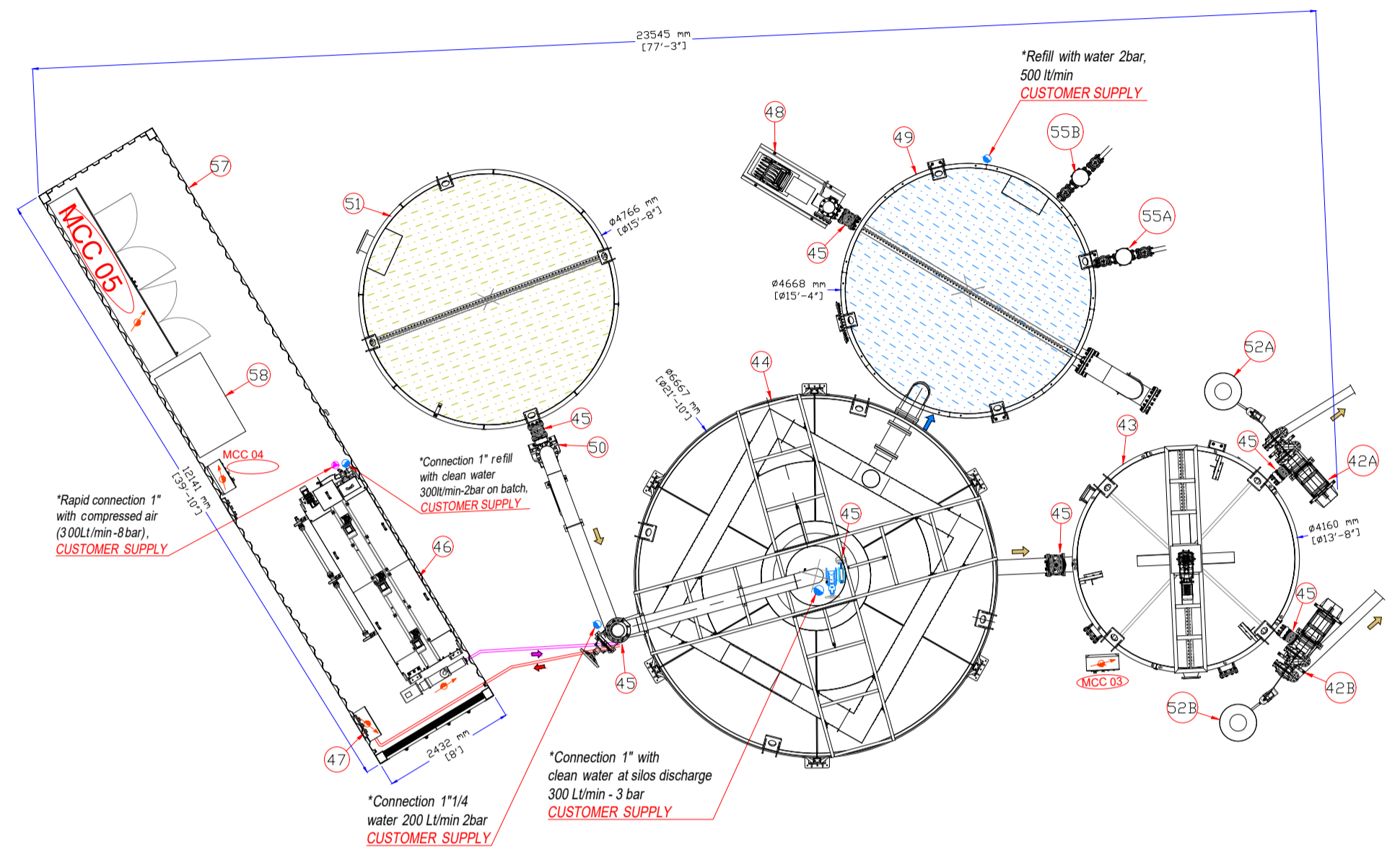

- GENERAL NOTES**
- All the dimensions are in millimeters unless otherwise specified.
 - All electrical cables are excluded from Matec supply unless otherwise specified in the contract.
 - All pneumatic connections are excluded from Matec supply unless otherwise specified in the contract.
 - All water connections are excluded from Matec supply unless otherwise specified in the contract.
 - All civil works are excluded from Matec supply unless otherwise specified in the contract.
 - The dimensions of the civil works are not executive. The same must be calculated and sized by a local engineer and the responsibility is not under Matec responsibilities.
 - Equipments earthing is not included in Matec's scope of supply and responsibilities.
 - Equipments not quoted in the drawings are for reference only, their dimensions are not executive.

ELECTRICAL PANEL LEGEND

Panel	Description	Power kW	Voltage Frequency
MCC 01	FILTERPRESS ELECTRICAL PANEL, supplies and distributes power to hydraulic power unit, feeding pump, kit flushing, drip tray, robowash and robowash feeding pump	104.37	415 V 50 Hz
MCC 02	FILTERPRESS ELECTRICAL PANEL, supplies and distributes power to hydraulic power unit, feeding pump, kit flushing, drip tray, robowash and robowash feeding pump	104.37	415 V 50 Hz
MCC 03	BIFANG ELECTRICAL PANEL, supplies and distributes power to slurry homogenizer tank and compressor	40.5	415 V 50 Hz
MCC 04	BIFLOC/DOSON ELECTRICAL PANEL, supplies and distributes power to automatic flocculant station, dosing screw pump and submersible pump	38.05	415 V 50 Hz
MCC 05	WASHING PLANT ELECTRICAL PANEL: supplies and distributes power to washing system and clean water relaunch pump	437	415 V 50 Hz

POS.	DESCRIPTION	MODEL	power kW	empty weight kg	working weight kg
***	Considering a material weight of 1.85 g/cm ³				
**	Considering a material weight of 1.8 g/cm ³				
*	Supplied by Customer				
59	n°3 Air tank	2.000 liters		3x 362	
58	Compressor		22	529	
57	Container 40'			2.900	
56	---				
55 B	Robowash feeding pump		30	240	
55 A	Robowash feeding pump		30	240	
54 B	Robowash	1.5 + 1.5	1.255		
54 A	Robowash	1.5 + 1.5	1.255		
53 B	Drip tray	2 x 4			
53 A	Drip tray	2 x 4			
52 B	Kit flushing		0.37		
52 A	Kit flushing		0.37		
51	Dirty water tank	50.000 liters		2.800	**92.800
50	Dirty water pump	6.000 LPM	30		
49	Clean water tank	100.000 liters		4.900	104.900
48	Clean water relaunch pump	6.000 LPM	90		
47	Flocculant automatic dosing system	DOSON	4.5		
46	Flocculant making station	BIFLOC 4500A	3.55	650	5.000
45	Aut. and Man. Valves				
44	Thickener silo decanter	200.000 lt		20.000	**380.000
43	Slurry homogenizer tank	BIFANG 100.000	18.5	7.800	**192.800
42 B	Filterpress feeding pump	DELTA 650-2H	37	1.400	
42 A	Filterpress feeding pump	DELTA 650-2H	37	1.400	
41 B	Filter press	FP1500_120P TT	22 + 4	40.400	***55.500
41 A	Filter press	FP1500_120P TT	22 + 4	40.400	***55.500

● electrical connection point
 ● water connection point
 ● air connection pipe

Customer: **E J LIDSTER LTD**

Scale: 1:100 Drawing code: B02_C210088_00_04

MATEC ENGINEERING
 via Aurelia Ovest, 383 54100 Massa (MS) Rev. 04
 tel. +39 0585 831034 fax +39 0585 836068 design by: Giovannelli Davide date: 12.07.22 pg. 4/7
 info@matecitalia.com www.matecitalia.com checked by: Zigni Alex date: 12.07.22 format: A1

This documentation is the property of MATEC srl: third party reproduction and transmission is strictly forbidden. Transgressors will be prosecuted to the full extent of the law.