

House Type J - Plot 13

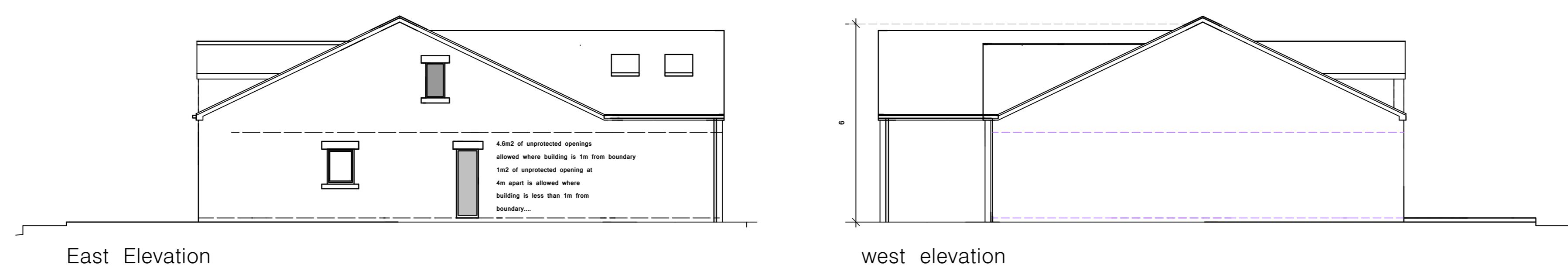
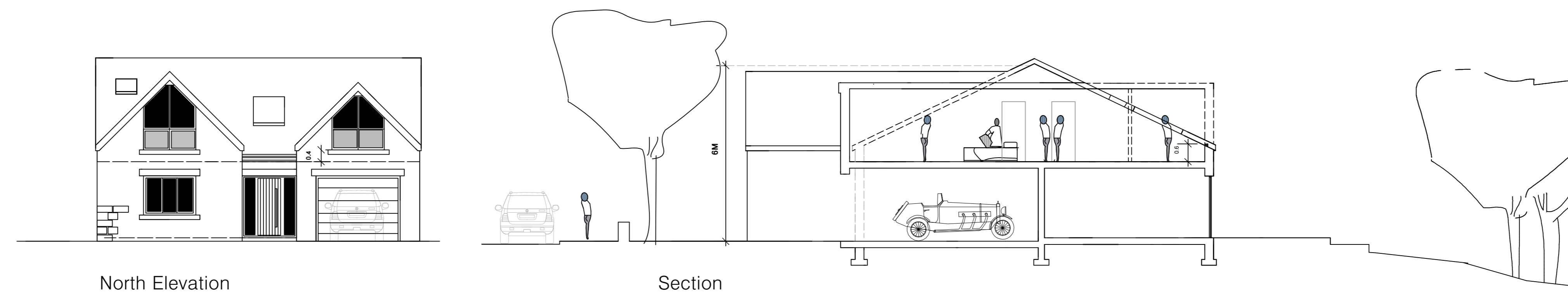
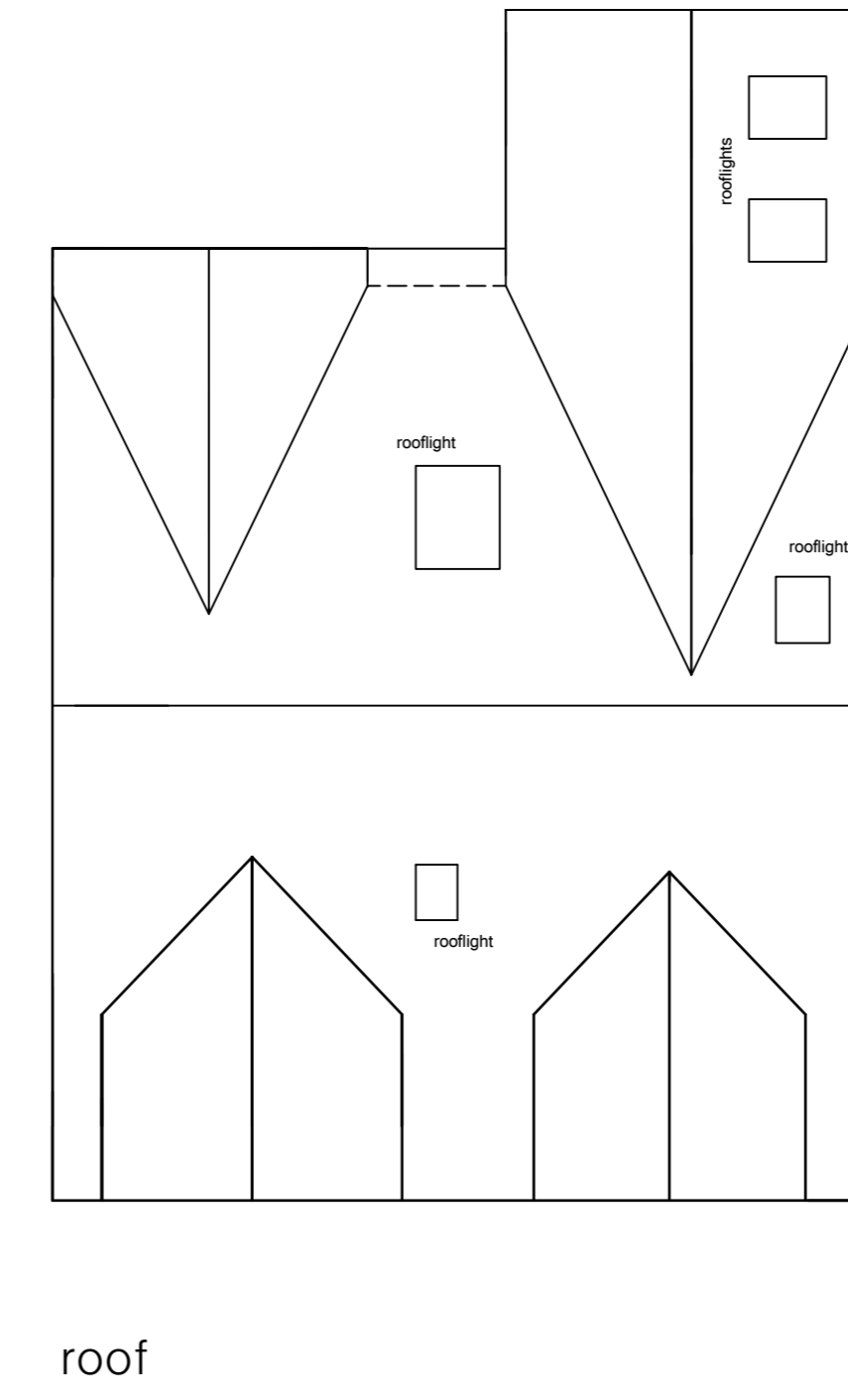
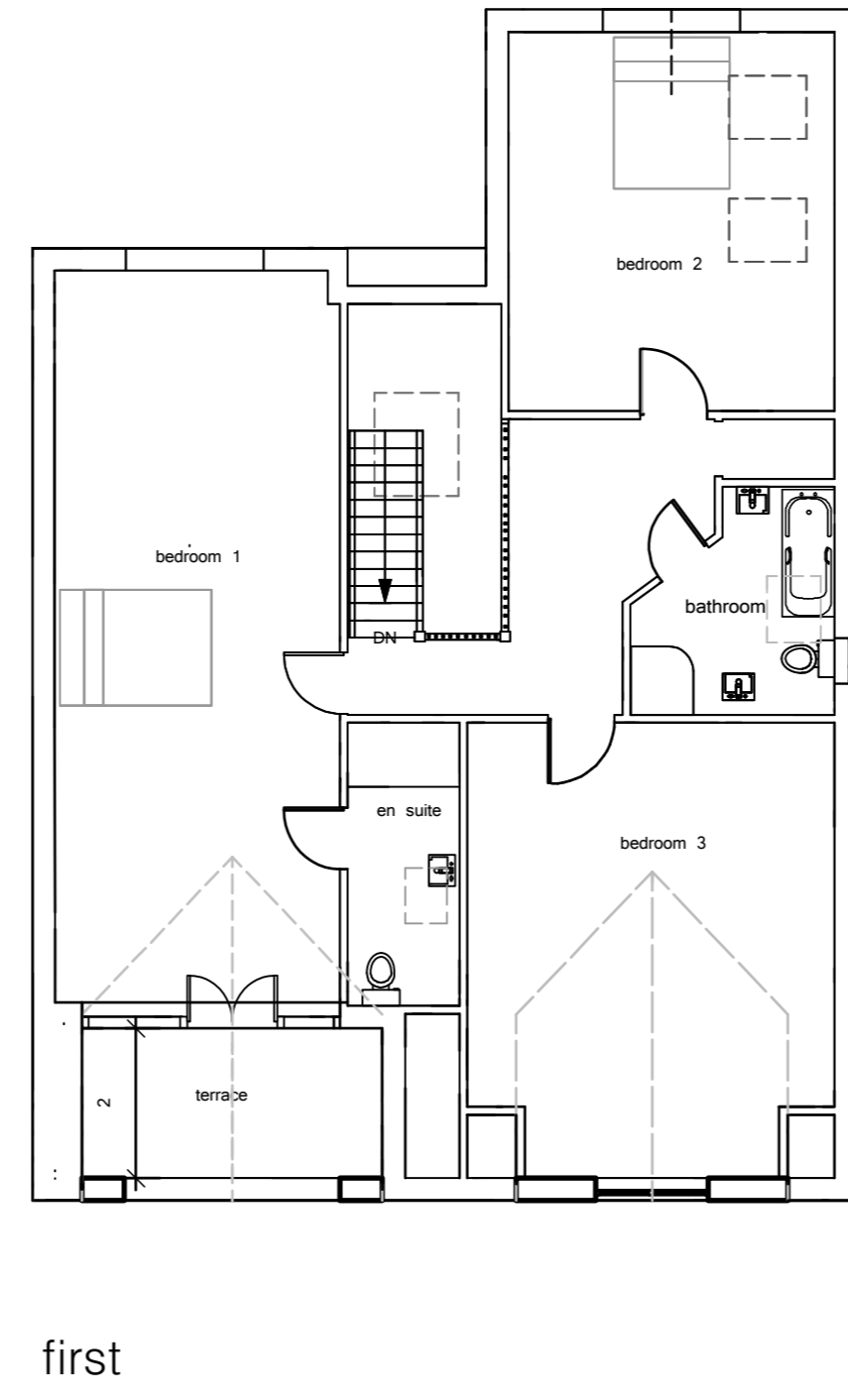
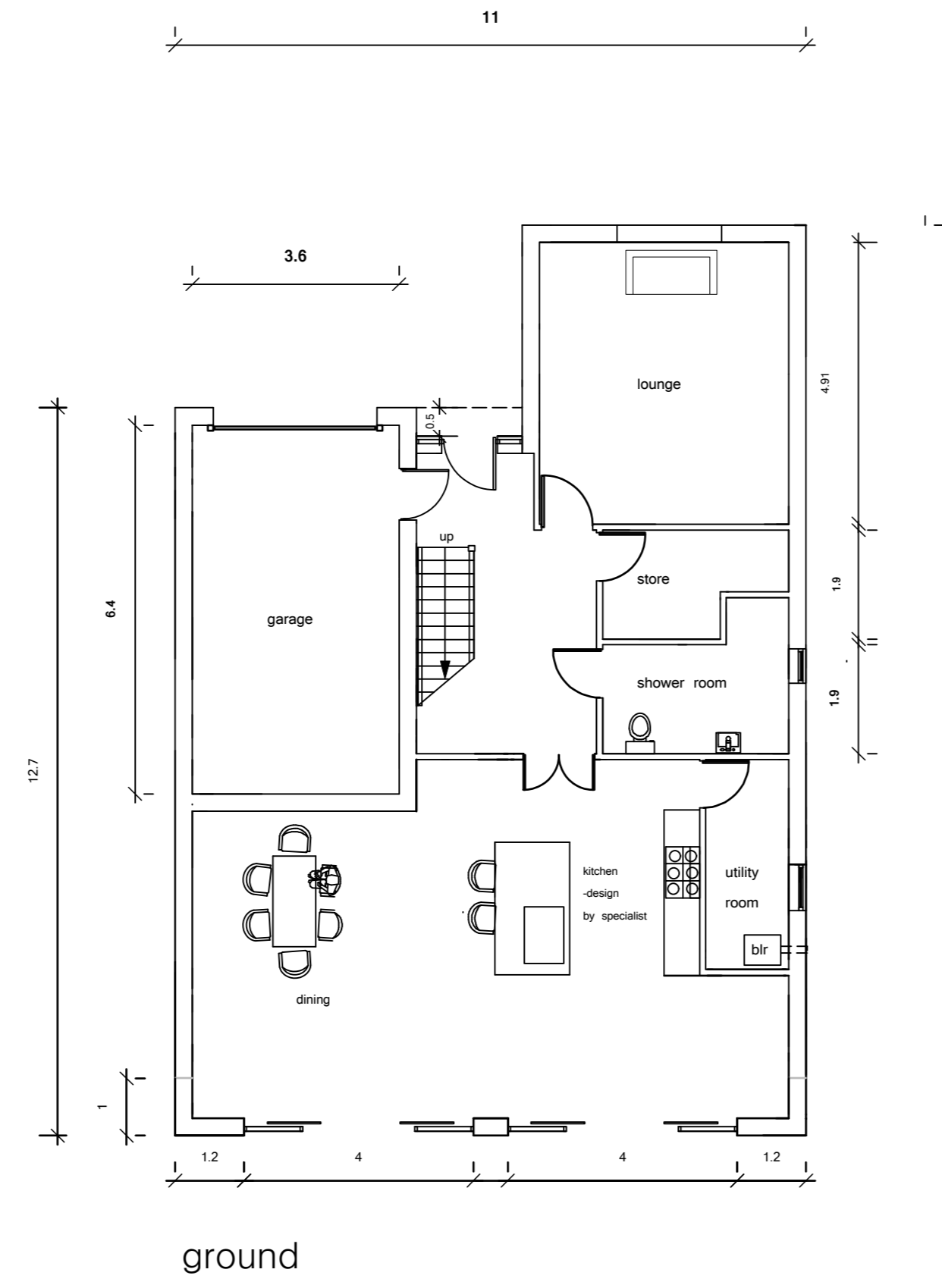

Notes

Walls
 Double-braided brick To Be Agreed With Planning Officer
 stone heads
 projecting stone sill

Roof
 Brick/Tile or Thru-roof
 conservation rooflight
 Brett Martin Cast Or Stormguard Aluminium
 Half Round Gutter

Windows
 Residence Collection Or Similar
 Upper Flush Fitting Casements.
 Detailing To Be Repeated Across Window Types.
 Windows Set Back 50mm In Reveal
 RAL Number To Be Agreed

All Soil And Vent Pipes To Be Internal

Notes/Advisories

No dimensions to be scaled from this drawing which is the property of the company A&A LTD. It is not to be used or disclosed in any way except as authorized by the company.

The architect A&A LTD owns all intellectual property rights including the copyright in this drawing and documents produced in performing the services. Any and all rights reserved. No part of any design by the architect may be registered by the client without written consent of A&A LTD.

The client is responsible for providing the architect with the correct site boundaries, dimensions and any constraints or easements relating to the site. A&A LTD will assume the boundaries as clearly delineated on the site plan provided by the client. No work to be carried out without planning permission. Use all the best planning conditions have been discharged and use a building regulations application has been submitted. Any work carried out before building regulations approval has been granted will be done at the client's own risk.

Principal Contractor/contract manager is responsible for ensuring works are signed off and certificate of completion is issued by building control.

Any building work within six (6) metres of a neighbouring property foundations shall remain the responsibility of the owner of that property. At least one month before the start work to be carried out the contractor shall be notified in writing of the location of any services. It is the responsibility of the contractor to ensure that any services are protected or diverted as appropriate. The contractor shall be responsible for ensuring that any services are protected or diverted as appropriate. The contractor shall be responsible for ensuring that any services are protected or diverted as appropriate.

NO GAS DRAWINGS WILL BE ISSUED TO ANY THIRD PARTY

REV	REVISION NOTE	DATE	DRAWN BY

Andrew Bailey		PADDOCK ROAD	
Architect		PHASE 2-3	
CLIENT: P&H PROPERTIES LTD	JOB NO: 2022	DATE: 2022	SCALE: 1:100 AT A3
DRAWING TITLE: PLANS SECTION AND ELEVATIONS	SHEET NO: 2/3	REV: 0	
RIRA	WORK STAGE: 3 - DEVELOPED DESIGN	DRAWN BY: JBS	CHECKED BY: JBS

A&A LTD
 15 LINDALL ROAD HORNWELL BARNLEY S73 9PL
 T: 01924 752991 E: ANDREW@A&AARCHITECTURE.CO.UK WWW.A&AARCHITECTURE.CO.UK
 COPYRIGHT © 2022 A&A LTD ALL RIGHTS RESERVED