



CUBIS

STAKKAbox™ Quad for BT Openreach

"The modern alternative to brick built chambers on new sites"



WHAT IS STAKKABOX™ QUAD?

STAKKAbOX™ Quad is a range of modular and structural preformed access chambers that prove a modern alternative to brick built chambers.

The system provides contractors with a means of constructing access chambers quickly and inexpensively, whilst offering improved build quality, reduced defects and enhanced site safety performance over traditional methods.

STAKKAbOX™ Quad is the ONLY modular access chamber approved for use on BT Openreach networks, available in 102, 104 and 106 sizes.

Supplied in 150mm deep twinwall rings, STAKKAbOX™ chambers are built by stacking sections to required depth. Each section weighs under 25kg, making it suitable for a single person to lift under manual handling guidelines.

The Quad system is moulded in HDPE and possesses excellent strength to weight properties. Each section is ribbed internally to improve loading performance.

Using the Quad system, complete chambers can be constructed from excavation to reinstatement in less than one hour.

NOTE
Excavation to reinstatement
in less than one hour

KEY BENEFITS



Simple Installation

Lightweight 150mm deep sections are stacked on top of a concrete or Type 1 base to build the chamber to the desired depth. There is no requirement for lifting plant or skilled box builders when building chambers.



Improved Quality

Brick built boxes regularly produce variable build quality standards resulting in frequent rejection by Openreach inspectors. The use of STAKKAbOX™ Quad eliminates this variability and offers a consistent installation every time.



Easy to Overbuild

Quad can be used to insert chambers over an existing network or for replacing chambers that have been damaged or need to be enlarged. Where required, rings can be cut to bridge over or around existing networks or obstacles.



Fast Reinstatement

Complete chambers can be constructed from excavation to reinstatement in less than one hour. This fast-track construction method saves time and money for the installer and reduces public liability risk.

FAQ'S

> Do I need cable bearers?

Bearers and locking pins are issued by British Telecom. Contractors will only require a drop-in wall bracket. For non-BT installations, please contact us for pricing for accessories.

> What vertical loading?

STAKKAbOX™ Quad is suitable for installations in areas rated C250 under BS: EN124: 1994. Quad is only approved for BT Openreach installations in pedestrian areas that are rated B125.

> When do I need a step?

A step is required for a chamber deeper than 600mm. Chambers deeper than 600mm will require an extra step after every additional 300mm.

> How do I create duct entries?

Duct entries are best created using a hole-saw and drill (compressed air, battery or 110v).

> What base is required?

A base can be constructed from: 50mm of dry mix concrete on 100mm of compacted Type 1; 150mm of compacted Type 1; 150mm deep concrete base (C20 or dry mix) or 50mm of ready mix concrete on 100mm of compacted Type 1

What backfill materials?

Unless agreed with local site representatives, the backfill should be Type 1 material, compacted in 150mm layers using a powered compactor.

Concrete Infill (B125)

- Covers lift and slide out
- One-person operation.
- No inherent scrap value
- Can be locked
- Kitemarked by BSI
- The only approved Concrete Infill cover for BT, Virgin Media and other network operators.

Recessed (B125)

- 75mm deep to suit 60mm block
- Can be filled with any material
- Tapered cover and centralised lifting keyholes
- Can be locked
- Kitemarked by BSI
- The only approved Recessed cover for BT, Virgin Media and other network operators.

Two Cover Options

Concrete Infill (B125) & Recessed (B125)

Meets Standard BT Sizes

JMF 102, 104 and 106 sizes

Frame & Cover Beds

directly on top of the chamber

Sub-security Plate

options for added security

Drop-in Furniture

Fit into pockets built into the chamber walls

150mm Deep

stacking section

Horizontal & Vertical Ribs

Improve vertical and sidewall load capabilities

Easy-cut Duct Entries

Duct entries can be cut as and where required using a hole saw mounted on a cordless drill. The chambers incorporate guides which identify drilling points to ensure correct duct spacing

PRODUCT PROFILE

BT Code	Internal Dimensions	Depth per section	Typical depth of chamber	Weight per section	CUBIS Product Code	Pallet Qty
JMF 102	725mm x 255mm	150mm	600mm	6.64kg	CPQBQ2-07250255-000000000	45
JMF 104	915mm x 445mm	150mm	750mm	13.62kg	CPQBQ4-09150445-000000000	30
JMF 106	1310mm x 610mm	150mm	750mm	18.79kg	CPQBQ6-13100610-000000000	17

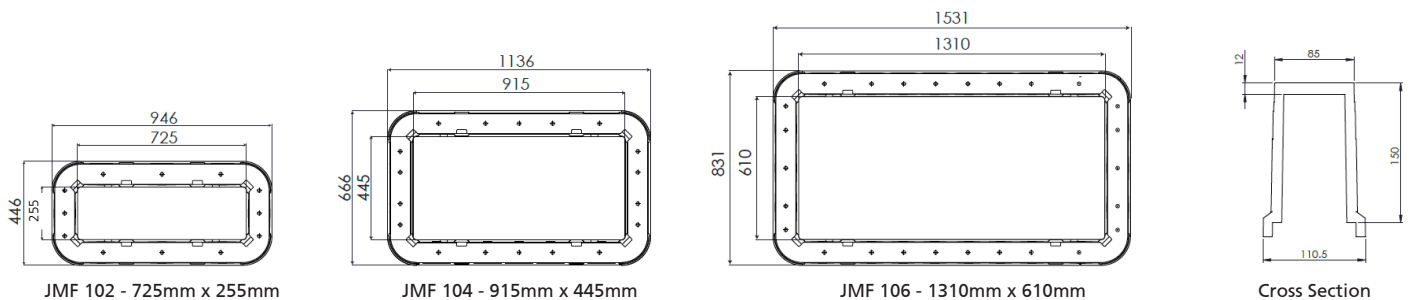

ACCESSORIES

Which accessories do I need?

Based on chambers that are built to standard depth

BT Code	Drop-in Wall Bracket ●	Drop-in Step ●
JMF 102	■	
JMF 104	■	■
JMF 106	■	■

NB: Drop-in step required when chamber is deeper than 600mm

COVER OPTIONS

Which covers can I use?

Based on chambers that are built to standard depth

BT Code	Concrete Infill ●	Recessed ●
JMF 102	■	■
JMF 104	■	■
JMF 106	■	■