



Mr Kabir Nepal

Project Name: Kabir Nepal Solar PV & Battery Storage

Phone: 07960434253

Address: Park House Bromley Carr Road, Bromley, S35
7DE

Date Created: 25th May 2022

Designer: John Clark

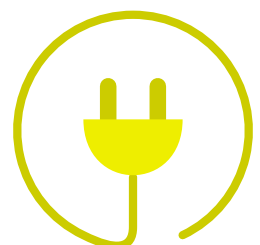
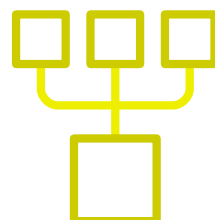
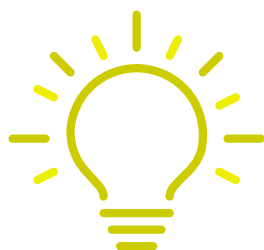
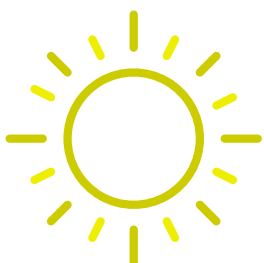

Roof Layout



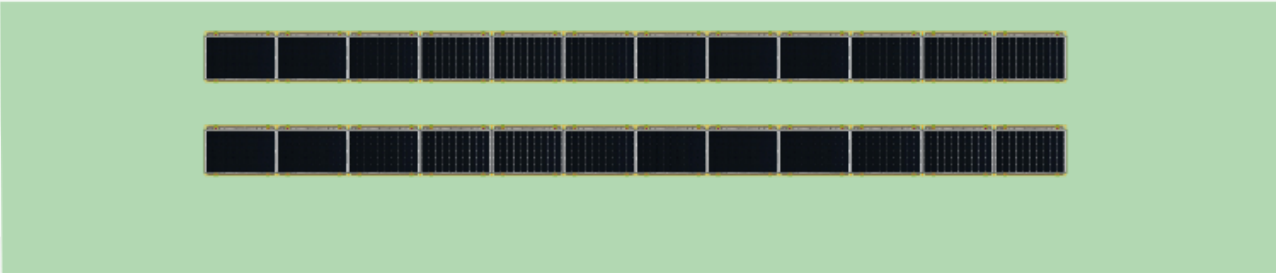





Field Ground Mount





GUTTER

Component list

Item	Quantity
	*HIH* Longi HiMo4 375W Black Framed Mono (white backsheet) solar panel 24
	Solis 8.0kW 5G Dual MPPT inverter 1
	LUX AC Coupled inverter 1
	Emlite ECA2 extended cover 1
	Label sheet 2
	AC isolator - KN 40A 3-pole 2
	Pair of MC4 connectors 4
	AC isolator - KN Newbury 20A 4-pole 2
	Uhome 2.4kw Battery 3
	50m reel of 4mm ² solar cable 1
	Renusol console 24
	Console mounting bar 48
	Console mounting clips - pack of 4 24



Inverter checks

Solis 8.0kW 5G Dual MPPT

Panels

PV power **9000** Rated AC output **8000**

Input 1: 12 *HIH* Longi HiMo4 375W Black Framed Mono (white backsheet) solar panels in 1 strings

Panels

Inverter

PV power	4500 W		
Open circuit voltage at -10° C	542 V	Max DC voltage	600 V
V _{mpp} at 40° C	399 V	V _{mpp} lower limit	90 V
V _{mpp} at -10° C	456 V	V _{mpp} upper limit	520 V
I _{mpp} at 40° C	11 A	Max DC input current	19.5 A

Max voltage

The open circuit voltage of the solar panels never exceeds the voltage limit of the inverter.



Max power point range

The maximum power point voltage of the solar panels is always above the lower limit of the inverter MPPT tracker. The maximum power point voltage of the solar panels is always below the upper limit of the inverter MPPT tracker.



Max Current

The maximum power point current of the solar panels is always below the maximum current for the inverter MPPT tracker.



Input 2: 12 *HIH* Longi HiMo4 375W Black Framed Mono (white backsheet) solar panels in 1 strings

Panels		Inverter	
PV power	4500 W		
Open circuit voltage at -10° C	542 V	Max DC voltage	600 V
V _{mpp} at 40° C	399 V	V _{mpp} lower limit	90 V
V _{mpp} at -10° C	456 V	V _{mpp} upper limit	520 V
I _{mpp} at 40° C	11 A	Max DC input current	19.5 A

Max voltage

The open circuit voltage of the solar panels never exceeds the voltage limit of the inverter.



Max power point range

The maximum power point voltage of the solar panels is always above the lower limit of the inverter MPPT tracker. The maximum power point voltage of the solar panels is always below the upper limit of the inverter MPPT tracker.



Max Current

The maximum power point current of the solar panels is always below the maximum current for the inverter MPPT tracker.



LUX AC Coupled



Panels

PV power

0 Rated AC output

null

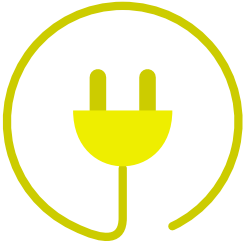

Electrical

Solis 8.0kW 5G Dual MPPT



AC Isolator

A AC isolator - KN 40A 3-pole has been specified for this input

Current

The rated isolator current (40A) is greater than the rated inverter current (34.8A)



Phases

The isolator is suitable for use on a single phase inverter.



Input 1



DC Isolator

Integrated isolator

This inverter contains an integrated DC Isolator.





Cable

10m of 4mm² solar cable has been specified

Voltage drop

Voltage drop at maximum power point at 40°C will be around
0.94 V (0.24 percent)



Input 2



DC Isolator

Integrated isolator

This inverter contains an integrated DC Isolator.



Cable

10m of 4mm² solar cable has been specified

Voltage drop

Voltage drop at maximum power point at 40°C will be around
0.94 V (0.24 percent)



LUX AC Coupled



AC Isolator

A AC isolator - KN Newbury 20A 4-pole has been specified for this input

Current

The rated isolator current (20A) is greater than the rated inverter current (16A)



Phases

The isolator is suitable for use on a single phase inverter.



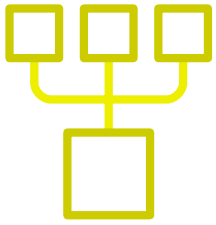

Schematic diagram

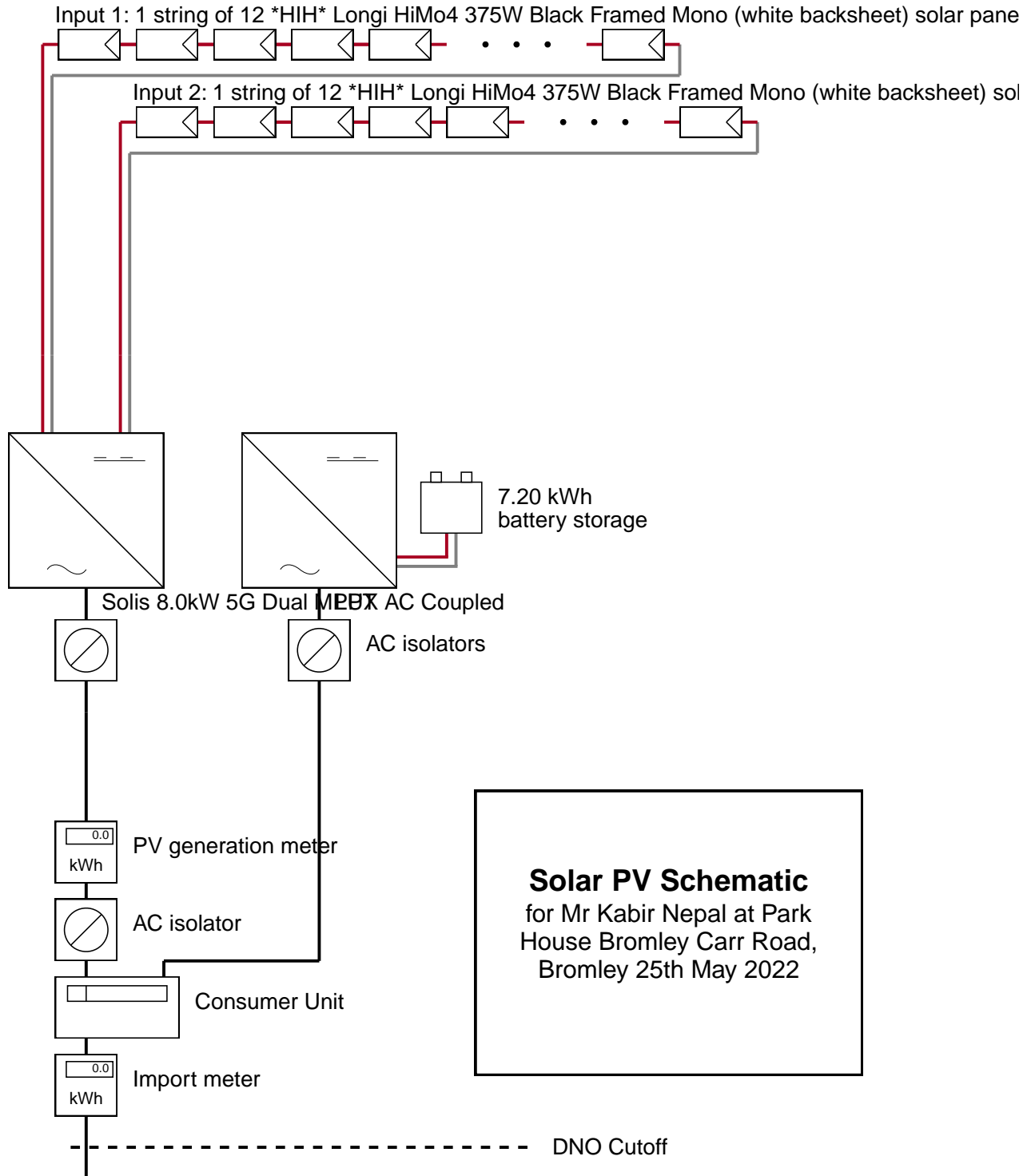



Structural calculations

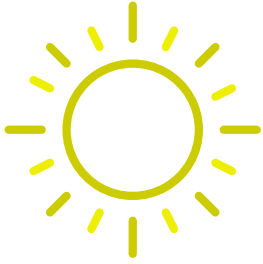

Performance Estimate

Site details

Client

Mr Kabir Nepal

Address

Park House Bromley Carr Road, Bromley

The sunpath diagram shows the arcs of the sky that the sun passes through at different times of the day and year as yellow blocks. The shaded area indicates the horizon as seen from the location of the solar array. Where objects on the horizon are within 10m of the array, an added semi-circle is drawn to represent the increased shading. Blocks of the sky that are shaded by objects on the horizon are coloured red, and a shading factor is calculated from the number of red blocks. The performance of the solar array is calculated by multiplying the size of the array (kWp) by the shading factor (sf) and a site correction factor (kk), taken from tables which take account of the geographical location, orientation and inclination of the array.

Inverter 1

Solis 8.0kW 5G Dual MPPT

Input 1

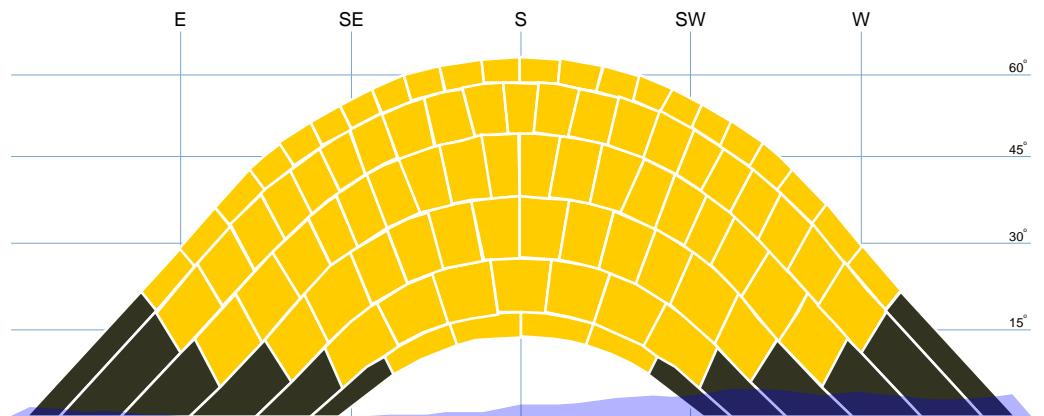

A. Installation data

Installed capacity of PV system - kWp (stc)	4.500	kWp
Orientation of the PV system - degrees from South	-23	°
Inclination of system - degrees from horizontal	30	°
Postcode region	11	



B. Performance calculations

kWh/kWp (Kk)	870	kWh/kWp
Shade factor (SF)	1.00	
Estimated output (kWp x Kk x SF)	3915	kWh

Input 2

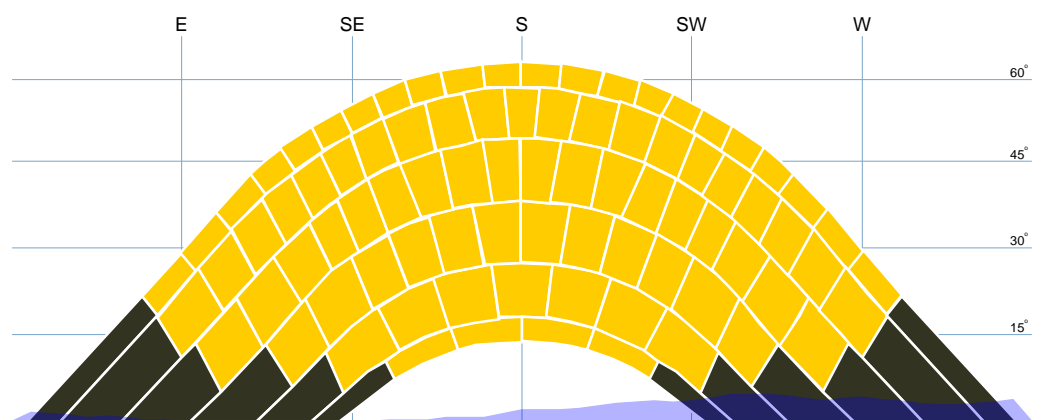
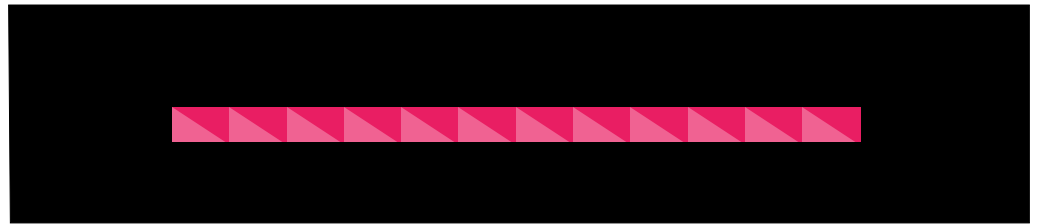

A. Installation data

Installed capacity of PV system - kWp (stc)	4.500	kWp
Orientation of the PV system - degrees from South	-23	°
Inclination of system - degrees from horizontal	30	°
Postcode region	11	



B. Performance calculations

kWh/kWp (Kk)	870	kWh/kWp
Shade factor (SF)	1.00	
Estimated output (kWp x Kk x SF)	3915	kWh

Performance Summary

A. Installation data		
Installed capacity of PV system - kWp (stc)	9	kWp
Orientation of the PV system - degrees from South	See individual inputs	
Inclination of system - degrees from horizontal	See individual inputs	
Postcode region	11	
B. Performance calculations		
kWh/kWp (Kk)	See individual inputs	
Shade factor (SF)	See individual inputs	
Estimated output (kWp x Kk x SF)	7830	kWh

Important Note: The performance of solar PV systems is impossible to predict with certainty due to the variability in the amount of solar radiation (sunlight) from location to location and from year to year. This estimate is based upon the standard MCS procedure is given as guidance only for the first year of generation. It should not be considered as a guarantee of performance.

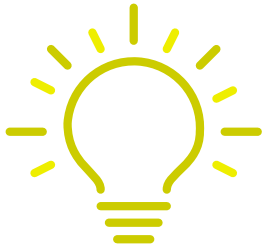

Self consumption

We model here the performance of a solar PV system with battery storage over the course of a year, using high resolution minute-by-minute generation data for a typical PV system and consumption data for a typical house, and calculating the flow of energy from the solar panels to the house and the battery during the day, and from the storage battery back to the house at night - or from the grid to the house when the battery is empty or loads exceed the discharge capacity of the system.

We provide yearly profiles of generation, consumption, import / export and battery utilisation, along with detailed profiles for a typical spring day.

Battery system specification

LUX AC Coupled with 3 Uhome 2.4kw Battery batteries

Charge rate	3000 W
Inverter charge efficiency	95.0 %
Inverter discharge efficiency	95.0 %
Battery efficiency	95.0 %
Round trip efficiency	85.7 %
Battery bank capacity	7.2 kWh
Max discharge depth	90 %
Usable capacity	6.48 kWh



Consumption

Electricity consumed in the property each year

28000 kWh



Generation

Electricity generated by the PV array each year

7856 kWh



Self consumption

Proportion of PV generation used in the property

85 %



Independence

Proportion of electricity consumption provided by PV

24 %



Import / Export

Electricity import / export each year from the property

21519 / 1098 kWh



Utilisation

Average daily utilisation of the storage battery

50 %

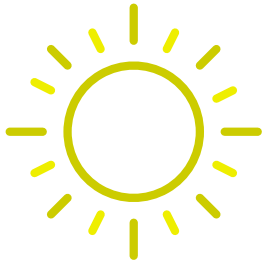

Yearly generation

The solar PV array is expected to generate 7856 kWh over a typical year. The graph shows whether the generated energy is used directly in the house, used to charge the storage battery, or exported to the grid.

70% (5486 kWh) of the electricity generated is expected to be used directly in the property. 16% (1272 kWh) is directed to the battery for later use, although 170 kWh of this is lost during battery charging and discharging. The remaining generation (1098 kWh, or 14% of the total) is exported to the grid.

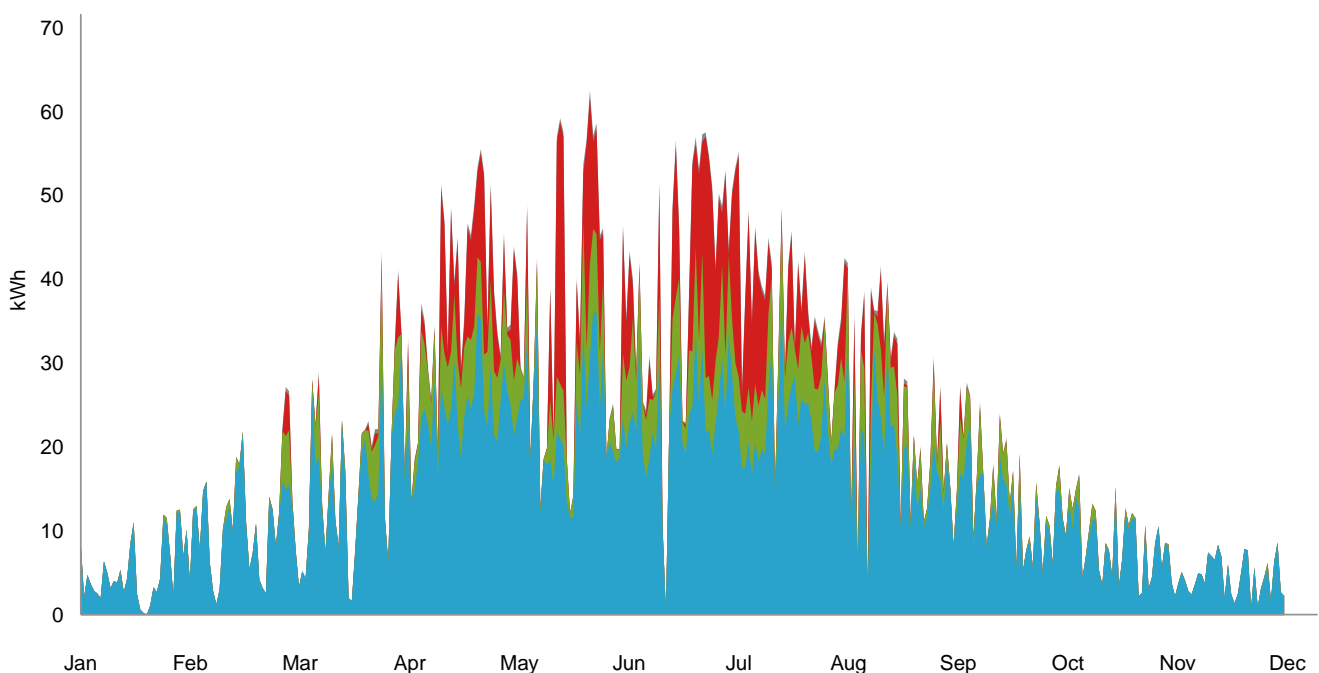
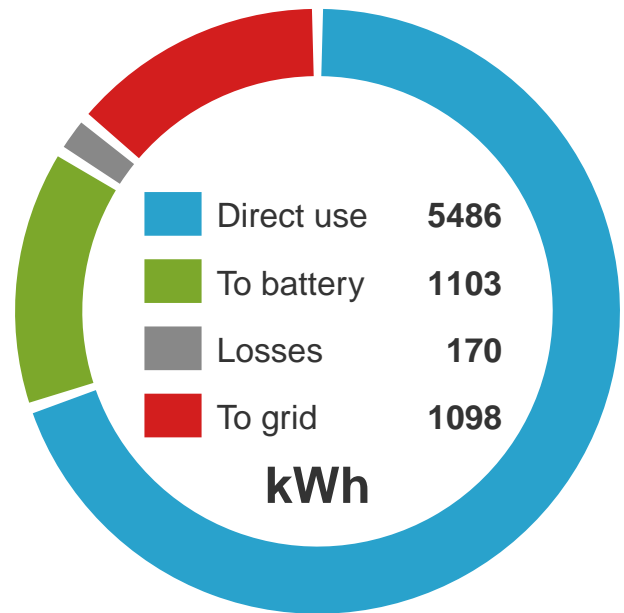

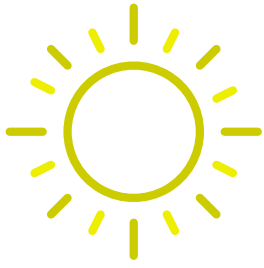

Daily generation

This graph shows the modelled profile of electricity generated by the PV array on a selected day (March 27th). On this day the PV system is expected to generate 22.2 kWh. Of this, 19.7 kWh (89%) is used directly in the property, 2.4 kWh (11%) is stored in the battery for later re-use, and 0.1 kWh (0%) is exported to the grid.

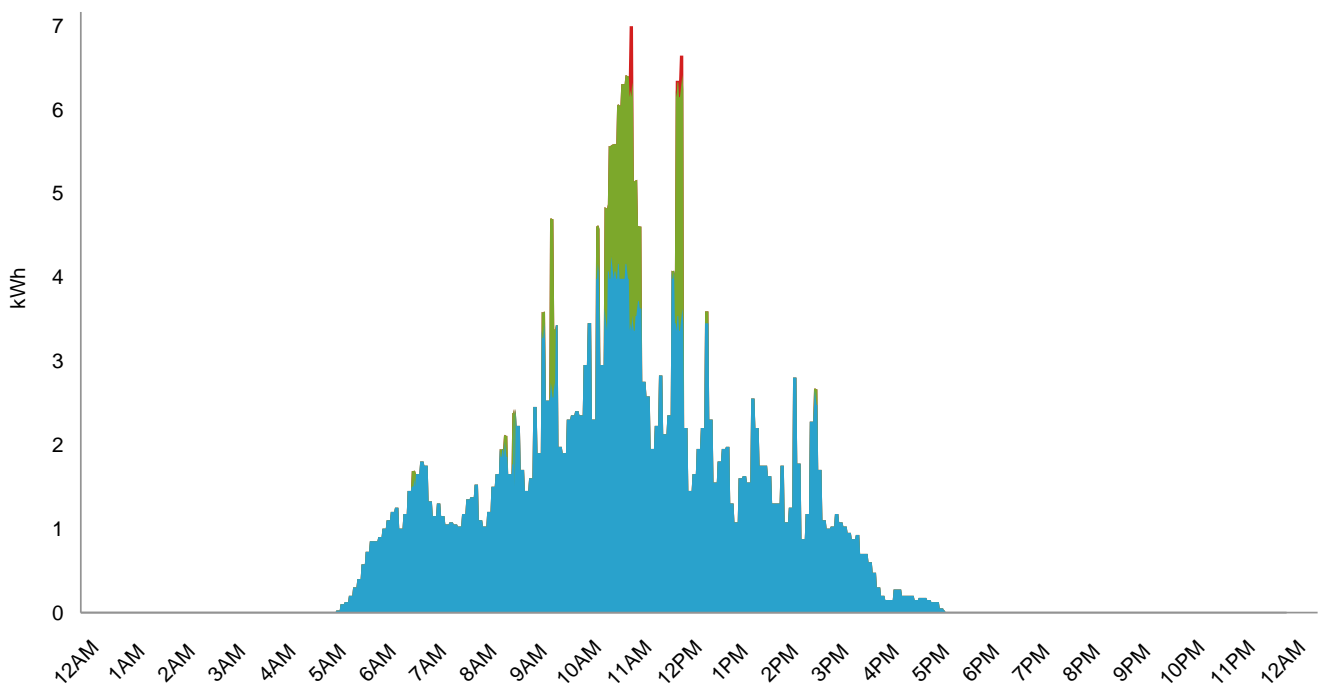
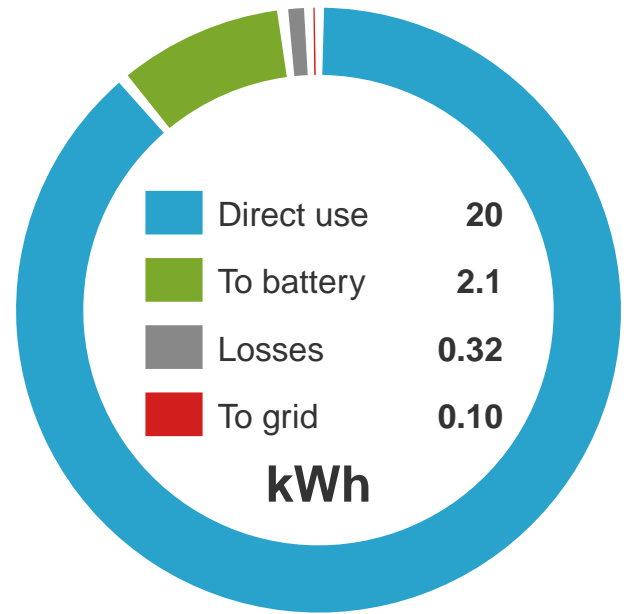

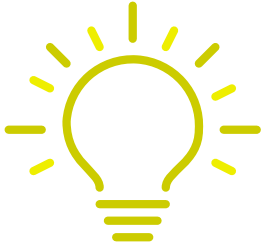

Yearly consumption

The property is expected to consume 28000kWh of electricity each year. Around 20% of this (5486 kWh) is expected to be supplied directly by the solar array. Another 4% (1106 kWh) is supplied from the storage battery. The remaining 77% (21519 kWh) is supplied from the grid.

The total self-consumption is expected to be 24% (6592 kWh) with the battery storage system. Without battery storage it would be 20% (5486 kWh).

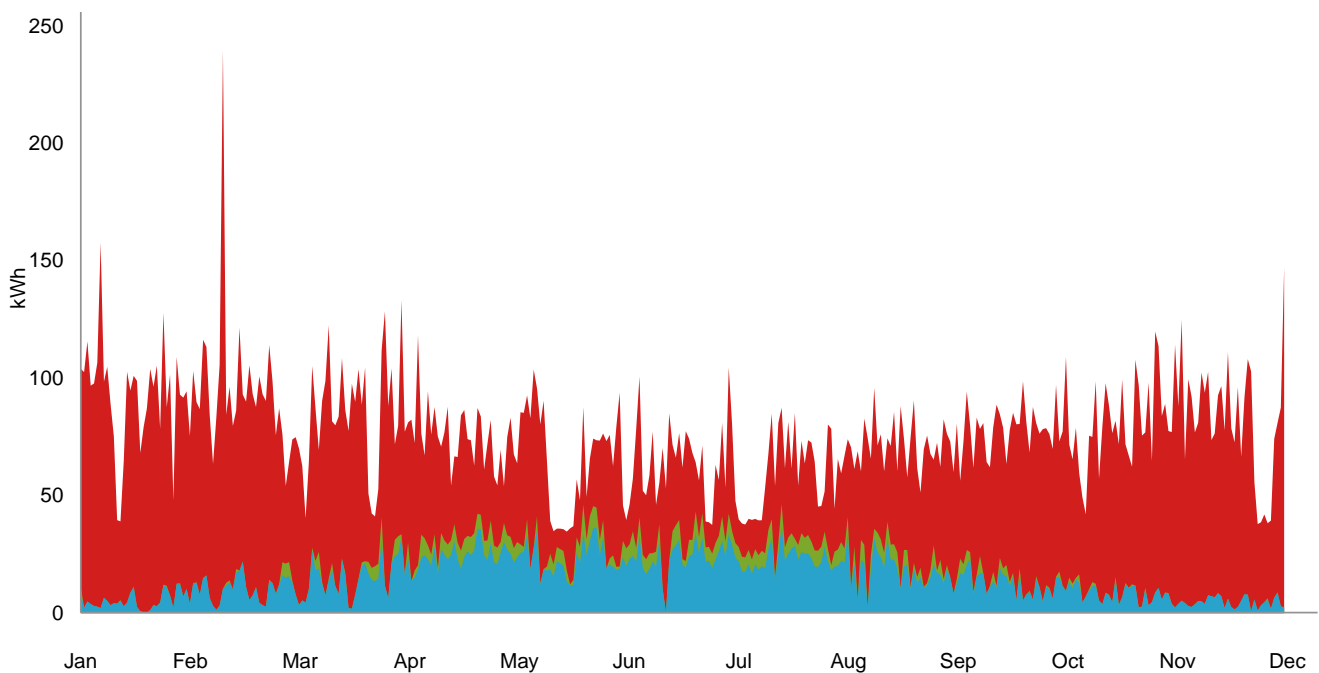
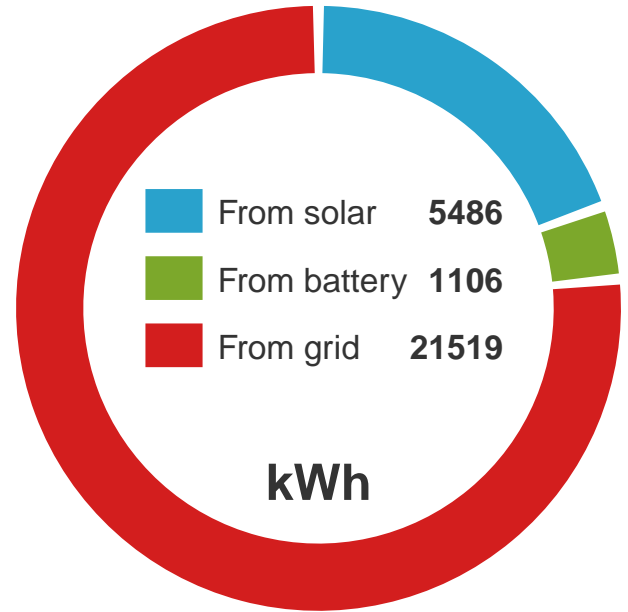

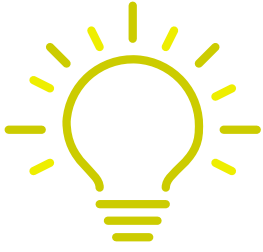

Daily consumption

This graph shows modelled consumption data over the course of the selected day (March 27th). Total electricity consumption on this day was 90.9 kWh, of which 19.7 kWh (22%) is expected to be supplied directly by the solar array, and a further 2.1 kWh (2%) drawn from the battery storage system. The remaining 69.2 kWh (76%) is imported from the grid.

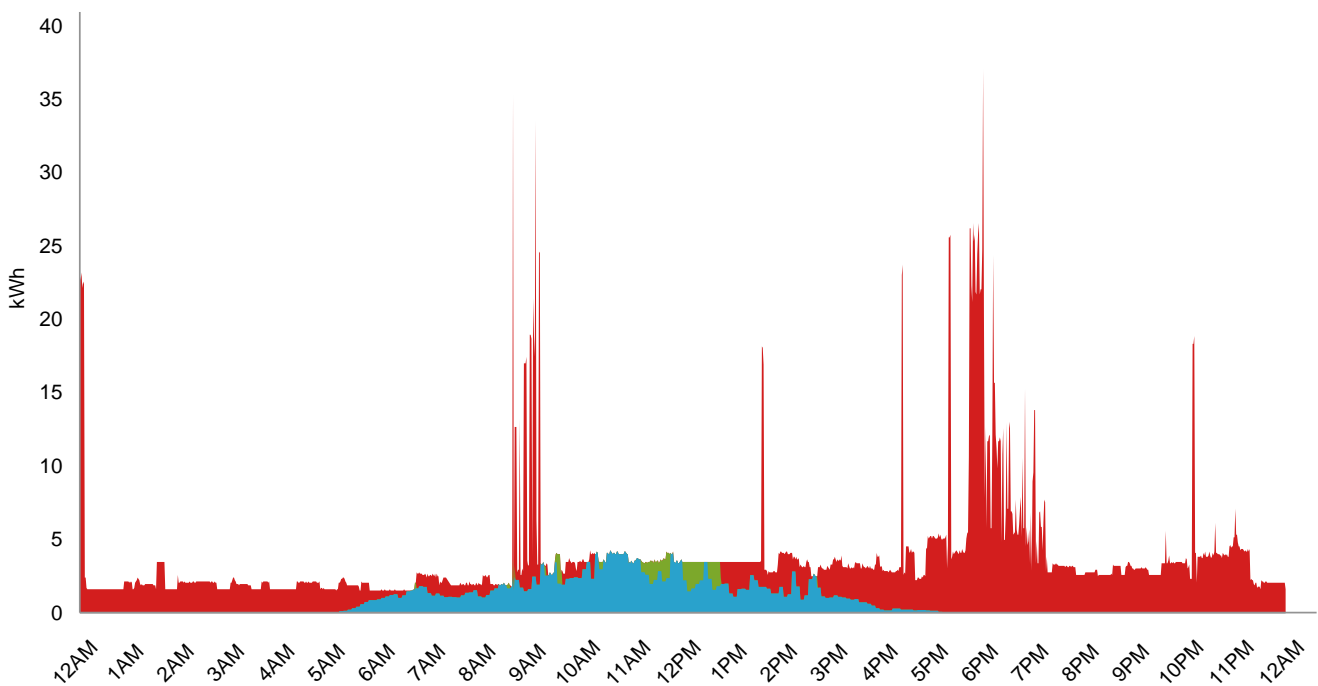
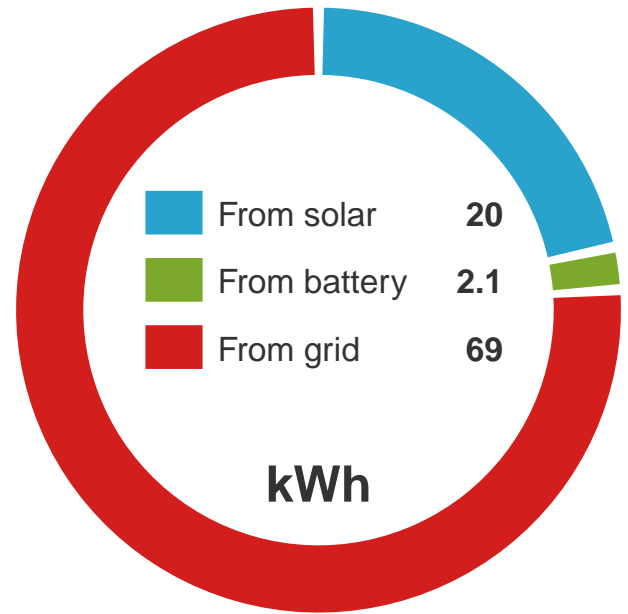

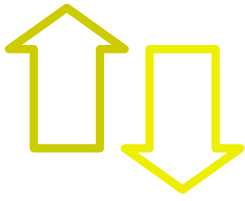

Yearly import and export

This graph shows modelled profiles of electricity imported and exported to and from the grid over the course of a year. The red area above the horizontal axis represents imported electricity, and the green area beneath the axis exported electricity.

Over the course of the year, a total of 21519 kWh is expected to be imported by the property, and 1098 kWh exported back to the grid.

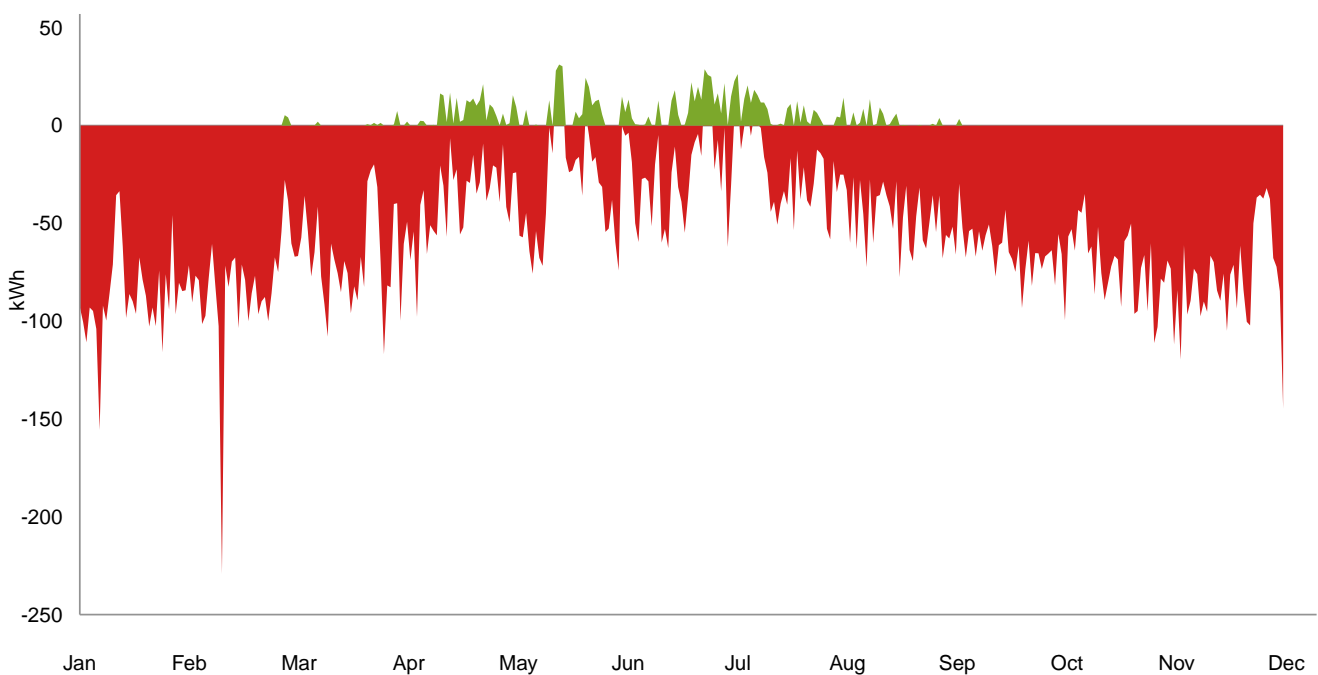
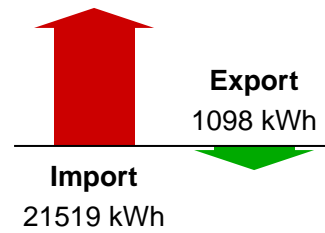

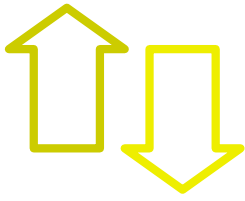

Daily import and export

This graph shows the modelled import and export of electricity over a selected day (March 27th). On this day 69.20 kWh is expected to be imported from the grid, and 0.1 kWh exported. At times when no import or export is shown the battery storage system is charging or discharging.

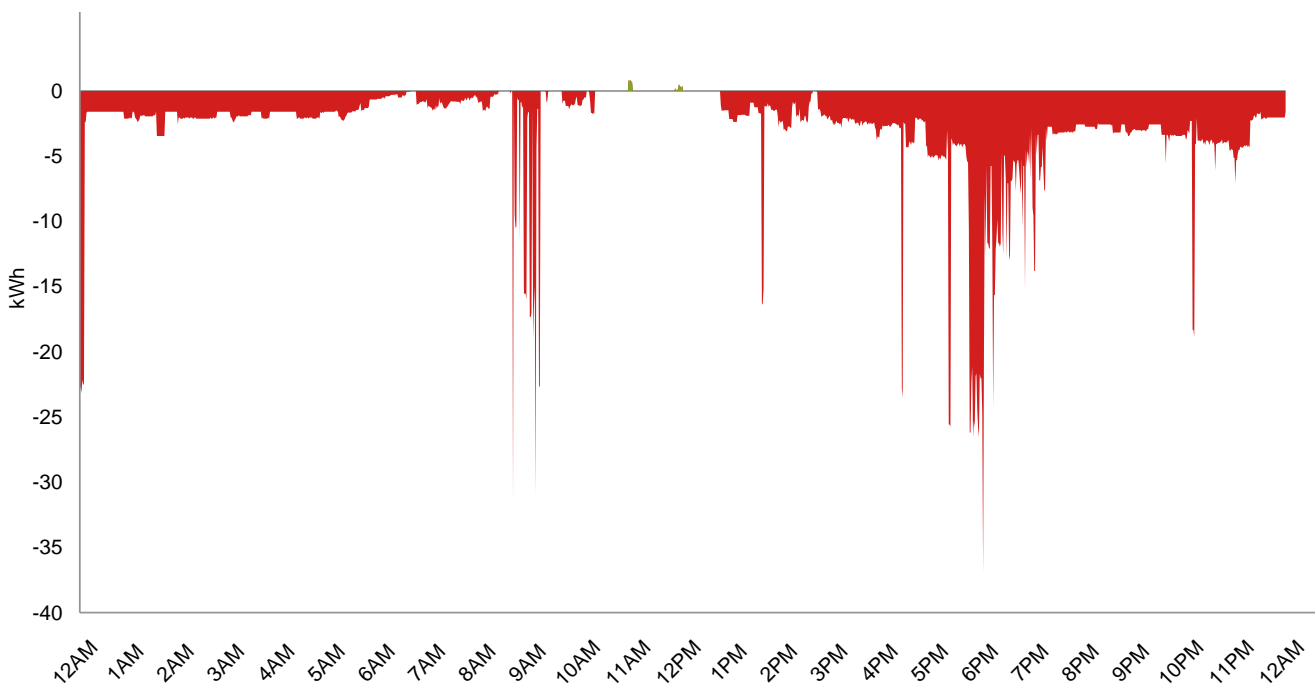
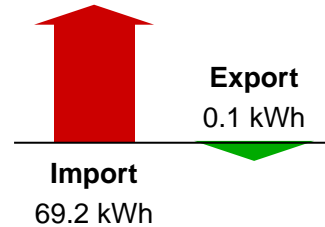

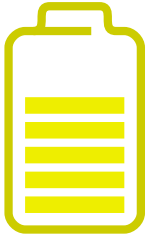

Yearly battery utilisation

The graph shows the modelled utilisation of the battery over the course of the year - the fraction of the available battery capacity that is actually charged and discharged each day. Utilisation of over 100% is possible at times where a battery is charged and discharged more than once during a day.

Low battery utilisation can be due to either insufficient spare PV generation to charge the battery (often the case in winter, or on cloudy days), or because loads are small overnight and the battery does not fully discharge.

Average battery utilisation

50%

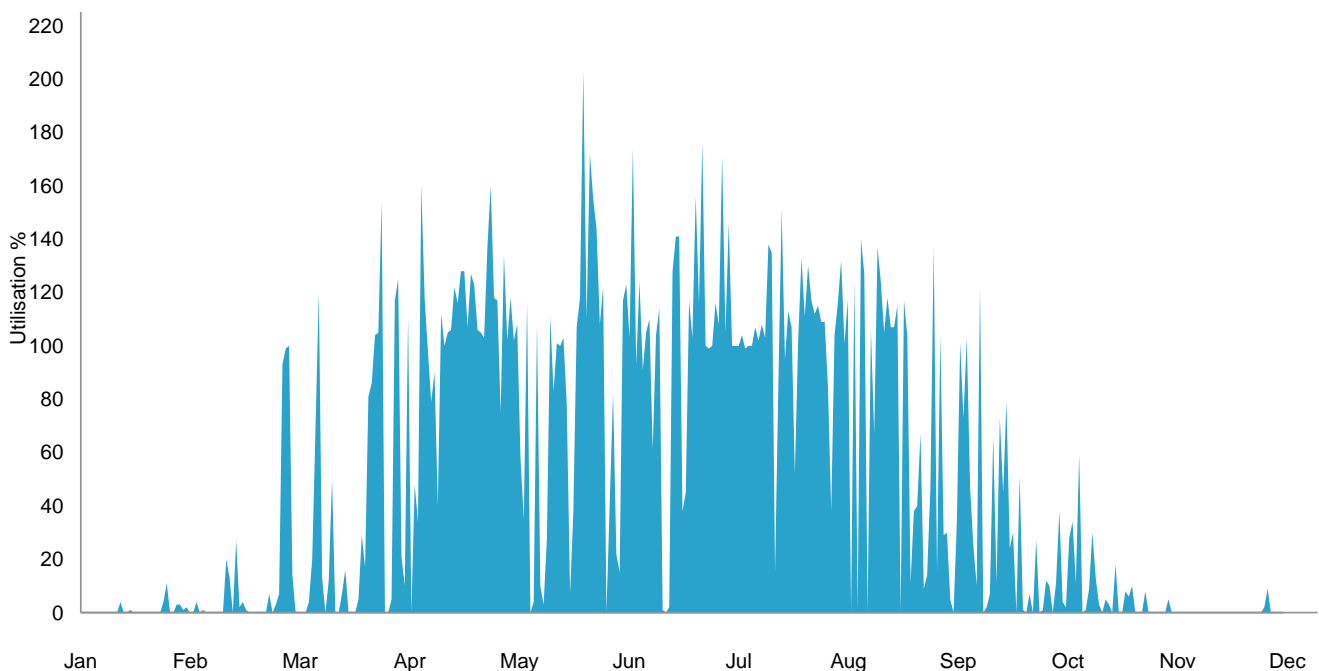
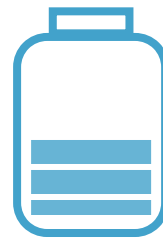

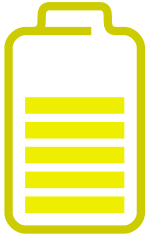

Daily battery utilisation

The state of charge of the battery over a selected day (March 27th) is shown in the graph below. The battery discharges overnight or when there is heavy demand during the day, and charges when there is excess solar PV generation during the day. On this day, 33% of the battery capacity was utilised.

Average battery utilisation

33%

