



SELWYNTREES

ARBORICULTURAL CONSULTANTS



# ARBORICULTURAL IMPACT ASSESSMENT

Land At Pear Tree Farm Brierley  
S72 9JR

16 July 2025

REF: 0514 Rev. B

**Prepared By:**

Rachel Selwyn  
Arboricultural Consultant

**Prepared For; Wayne Bennett**

**Our Ref: 0514 Rev. B**

Author: 

---

Rachel Selwyn  
Arboricultural Consultant

**Reviewer:**



---

Celia Selwyn  
Selwyn Trees

This report dated 16 July 2025 has been prepared for Wayne Bennett (the "Client") in accordance with the terms and conditions of appointment dated 01 June 2025 (the "Appointment") between the Client and **Selwyn Trees** for the purposes specified in the Appointment. For avoidance of doubt, no other person(s) may use or rely upon this report or its contents, and Selwyn Trees accepts no responsibility for any such use or reliance thereon by any other third party.



## Version Control

Issue	Revision No.	Date Issued	Page No.	Description	Reviewed By
A	1	14 July 2025	All	AIA	Celia Selwyn
B	1	16 July 2025	All	AIA	Rachel Selwyn

# **1 Contents**

<b>Version Control</b> .....	<b>3</b>
<b>1 Contents</b> .....	<b>4</b>
<b>2 Introduction</b> .....	<b>5</b>
<b>3 Policy and Guidance</b> .....	<b>6</b>
<b>4 Desk-based Study</b> .....	<b>8</b>
<b>5 BS5837 Tree Survey &amp; Tree Schedule</b> .....	<b>10</b>
<b>6 Tree Constraints Plan:</b> .....	<b>27</b>
<b>7 Arboricultural Impacts Plan:</b> .....	<b>29</b>
<b>8 Outline Tree Protection Plan:</b> .....	<b>31</b>
<b>9 Arboricultural Impact Assessment</b> .....	<b>33</b>
<b>Appendix A- Tree Works Schedule</b> .....	<b>45</b>
<b>Appendix B- Arboricultural Survey information &amp; Key</b> .....	<b>45</b>
<b>Appendix C: Caveats and Limitations</b> .....	<b>47</b>
<b>Appendix D: Author’s Qualifications and experience</b> .....	<b>48</b>
<b>Appendix D: British Standard BS 5837:2012 Table 1 Cascade chart for Tree Quality Assessment:</b> .....	<b>49</b>

## 2 Introduction

- 2.1.1 Wanye Bennett engaged Selwyn Trees to carry out an Arboricultural Impact Assessment for a site on Land at Pear Tree Farm, Brierley, Barnsley S72 9JR.
- 2.1.2 The purpose of this Arboricultural Impact Assessment report was to advise on any Arboricultural issues which relate to a proposed development. An initial Arboricultural Survey site visit was carried out on the 18<sup>th</sup> June 2024. The survey was carried out in accordance with BS5837: 2012- 'Trees in relation to Design, Demolition and Construction.
- 2.1.3 An application is being submitted to Barnsley Metropolitan Borough Council for the demolition of existing dwelling and farm buildings, and the erection of 10 new dwellings, detached, and terraced. The proposal assessed in this Impact Assessment is as shown in the drawing referenced as "4038-03b"
- 2.1.4 The following documents were provided:

*Table 1- Reference documents*

<b>Document</b>	<b>Reference number</b>
Site Plan	4038-01
Topographical survey	BLD461SP
Proposal Plan	4038-03b

## 3 Policy and Guidance

### National Planning Policy Framework (NPPF)

- 3.1.1 The following paragraphs within the NPPF<sup>1</sup> set out policies which guide the planning policy and decision-making process of Local Planning Authorities in relation to trees. These are:
- 3.1.2 **Paragraph 136:** “Trees make an important contribution to the character and quality of urban environments and can also help mitigate and adapt to climate change. Planning policies and decisions should ensure that new streets are tree-lined, that opportunities are taken to incorporate trees elsewhere in developments (such as parks and community orchards), that appropriate measures are in place to secure the long-term maintenance of newly-planted trees, and that existing trees are retained wherever possible. Applicants and local planning authorities should work with highways officers and tree officers to ensure that the right trees are planted in the right places, and solutions are found that are compatible with highways standards and the needs of different users.”
- 3.1.3 **Paragraph 187:** “Planning policies and decisions should contribute to and enhance the natural and local environment by:
- 3.1.4 a) protecting and enhancing valued landscapes, sites of biodiversity or geological value and soils (in a manner commensurate with their statutory status or identified quality in the development plan);
- 3.1.5 b) recognising the intrinsic character and beauty of the countryside, and the wider benefits from natural capital and ecosystem services – including the economic and other benefits of the best and most versatile agricultural land, and of trees and woodland;
- 3.1.6 d) minimising impacts on and providing net gains for biodiversity, including by establishing coherent ecological networks that are more resilient to current and future pressures and incorporating features which support priority or threatened species such as swifts, bats and hedgehogs;
- 3.1.7 e) preventing new and existing development from contributing to, being put at unacceptable risk from, or being adversely affected by, unacceptable levels of soil, air, water or noise pollution or land instability. Development should, wherever possible, help to improve local environmental conditions such as air and water quality, taking into account relevant information such as river basin management plans;
- 3.1.8 **Paragraph 188:** “Plans should: distinguish between the hierarchy of international, national and locally designated sites; allocate land with the least environmental or amenity value, where consistent with other policies in this Framework<sup>65</sup>; take a strategic approach to maintaining and enhancing networks of habitats and green infrastructure; and plan for the enhancement of natural capital at a catchment or landscape scale across local authority boundaries
- 3.1.9 **Paragraph 192:** To protect and enhance biodiversity and geodiversity, plans should:

---

<sup>1</sup> [https://assets.publishing.service.gov.uk/media/65a11af7e8f5ec000f1f8c46/NPPF\\_December\\_2023.pdf](https://assets.publishing.service.gov.uk/media/65a11af7e8f5ec000f1f8c46/NPPF_December_2023.pdf)

- 3.1.10 b) promote the conservation, restoration and enhancement of priority habitats, ecological networks and the protection and recovery of priority species; and identify and pursue opportunities for securing measurable net gains for biodiversity.
- 3.1.11 **Paragraph 193:** When determining planning applications, local planning authorities should apply the following principles:
- 3.1.12 a) if significant harm to biodiversity resulting from a development cannot be avoided (through locating on an alternative site with less harmful impacts), adequately mitigated, or, as a last resort, compensated for, then planning permission should be refused;
- 3.1.13 c) development resulting in the loss or deterioration of irreplaceable habitats (such as ancient woodland and ancient or veteran trees) should be refused, unless there are wholly exceptional reasons and a suitable compensation strategy exists; and
- 3.1.14 d) development whose primary objective is to conserve or enhance biodiversity should be supported; while opportunities to improve biodiversity in and around developments should be integrated as part of their design, especially where this can secure measurable net gains for biodiversity or enhance public access to nature where this is appropriate.

## Guidance Documents

- 3.1.15 This AIA had been written making reference to, and in accordance with, the following guidance documents:
- 3.1.16 BS5837:2012 'Trees in relation to design, demolition and construction – recommendations'
- 3.1.17 BS3998:2010 Tree work – recommendations
- 3.1.18 NJUG 4 – National Joint Utilities Group "Guidelines for the planning, installation and maintenance of utility apparatus in proximity to trees. Volume 4, issue 2. London: NJUG 2007" To include Operatives Hand-out Guidance
- 3.1.19 BGS Open Source Soil Data <http://www.bgs.ac.uk/nercsoilportal/maps.html>
- 3.1.20 Cranfield University Soilscales LandIS Land Information: <http://www.landis.org.uk/services/soilscales.cfm>
- 3.1.21 'Guidance Note 12: The Use of Cellular Confinement Systems Near Trees: A Guide to Good Practice', by the Arboricultural Association (2020).
- 3.1.22 Ground Protection Practice Note GPPN8/21, Tree Root Protection using Temporary Access Trackways, By M J Oliver, Product Development Manager, GroundGuards.

## 4 Desk-based Study

### Statutory Tree Protection and Designation

#### TPO (Tree Preservation Order) and Conservation Area Status

- 4.1.1 According to the interactive map on the Barnsley Metropolitan Borough Council Website, the site is within the Brierley Conservation Area. there are no TPO's (Tree Preservation Orders) present on the site but TPO's are present on the surrounding land as shown below.

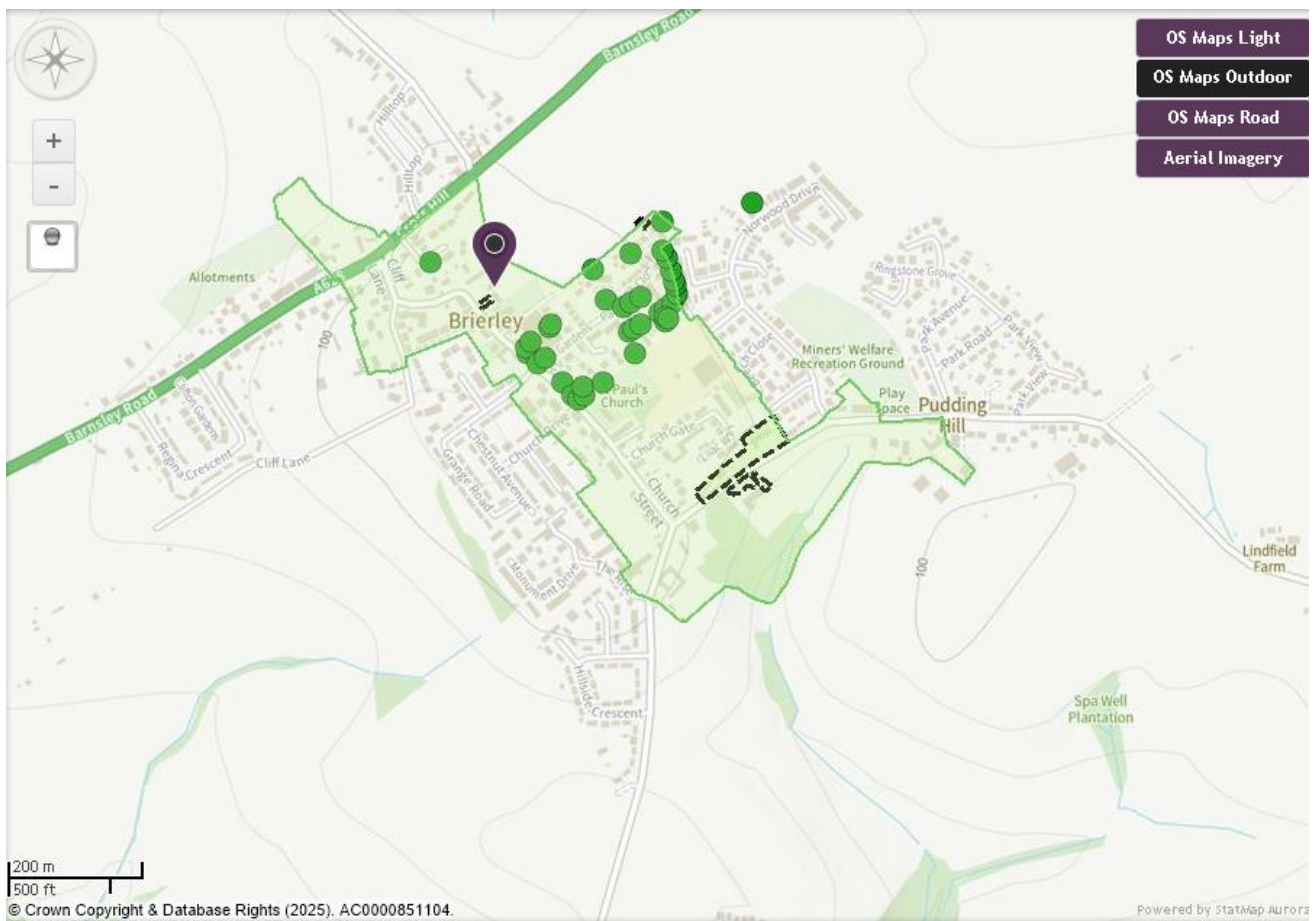

Figure 1: Excerpt from interactive map on Barnsley Metropolitan Borough Council website showing Brierley Conservation Area

#### 4.1.2 Physical Site Information

4.1.3 The site surveyed is land at Pear Tree Farm Brierley Barnsley S75 9JR. The site is an operational farm with produce being grown in the surrounding fields to the Northeast.



*Figure 2- An aerial view of the site. The red outlined area is the section of the site assessed within this Impact Assessment from Google Maps ©.*

4.1.4 The site currently consists of various farm buildings, a residential dwelling, an access driveway to the residential dwelling, and front garden. The agricultural fields to the Northeast belong to the site but are not included within this proposal.

4.1.5 The road, Church Street, lies to the Southwest of the site and is the main access way into the site. Residential dwellings border the site to the Northwest. Brierley Methodist Church borders to the site to the East/ Southeast. Agricultural fields border the site to the Northeast.

4.1.6 According to the LANDIS Soilscales application from the Cranfield Soil and Agrifood Institute (2025) the soil type in the area of the site is: **“Freely draining slightly acid loamy soils”**.

4.1.7 The Bedrock geology of the site is “Brierley Rock - Sandstone. Sedimentary bedrock formed between 315.2 and 309.5 million years ago during the Carboniferous period. [BGS Geology Viewer - British Geological Survey](#)





4.1.8 Flood Risk and Flood Zone: 1

4.1.9 According to the Flood Map for Planning service, the site is within Flood Zone 1. As defined by the UK's Environment Agency, "Flood Zone 1" signifies areas with the lowest probability of flooding. This zone is classified as having less than a 0.1% annual probability of river or sea flooding, equating to less than 1 in 1000 chance. <https://flood-map-for-planning.service.gov.uk/map?cz=453690.1,402675.7,18.890493>

## 5 BS5837 Tree Survey & Tree Schedule



### Survey Summary





- 5.1.1 An initial Arboricultural Survey site visit was carried out by Selwyn Trees on the 18<sup>th</sup> June 2025. The data was collected and report compiled by Rachel Selwyn, BSc (Hons) in Arboriculture and Urban Forestry, who has 10 years of experience working for Selwyn Trees and is a professional member of the Arboricultural Association.
- 5.1.2 The survey was carried out and the information provided in this report has been compiled in accordance with the relevant British Standard- BS5837:2012- 'Trees in relation to design demolition and construction recommendations. The purpose of this Impact Assessment report is to advise on any Arboricultural issues which relate to a proposed development.
- 5.1.3 The West of the site consists of Semi-mature trees which are visible from the road to the West. These trees provide some amenity value for the local area. Off-site trees are present to the East within the ground of Brierley Methodist Church Hedges are present on the site bordering Church Street to the West. Southwest and to the North and Northeast.
- 5.1.4 The BS5837:2012 Arboricultural Survey with Schedule is shown on the following pages:

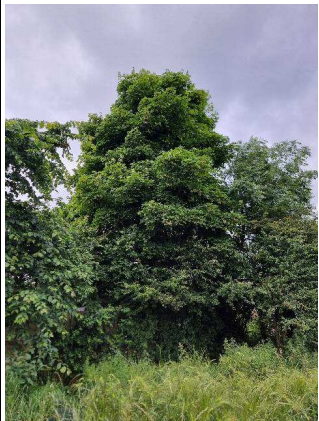



RETENTION CATEGORY		SUB CATEGORY		SURVEY LIMITATIONS		SURVEY DETAILS	
	A - High Quality (40 years remaining contribution)	1- Mainly Arboricultural Qualities	- This tree survey is to be limited to planning purposes only.	- This tree survey is to be limited to planning purposes only. - This tree survey is not a tree risk assessment. - This survey was undertaken from ground level using visual assessment. - Where access was restricted attributes and dimensions were estimated. - The weather condition on the day of the survey was: <b>Mostly dry with light showers</b>		DATE OF SURVEY- 18.06.2024	
	B - Moderate Quality (20 years remaining contribution)	2- Mainly Landscape Qualities	- This tree survey is not a tree risk assessment.			CLIENT- Building Link Design Ltd.	
	C - Low Quality (10 years remaining contribution)	3- Mainly Cultural Qualities	- This survey was undertaken from ground level using visual assessment.			SITE- Land at Pear Tree Farm, Brielerly, Barnsley	
	U - Unsuitable for retention	RPA = Root Protection Area	- Where access was restricted attributes and dimensions were estimated.			S72 9LR	
						REFERENCE- 515- Tree Data Table- A	
						SURVEYOR- Rachel Selwyn	

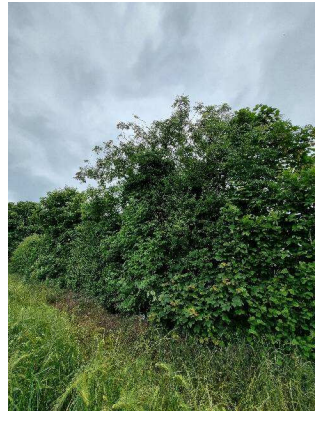







**BS5837:2012 - Tree Data Table**





Tree No.	Tree Species Common & Latin Name	Photo	Tree Height	Crown Spread				Height of Crown Clearance	Height of First Significant Branch & Direction of Growth	Age Class	Comments- Tree Location/Condition/ Landscape Significance	Initial Recommendations	Tree Trunk Diameter at 1.5m (Estimated Yes or No)	RPA Radius (m)	RPA (m <sup>2</sup> )	Estimated remaining Contribution	BS5837 Retention Category
				N	E	S	W										
T264	COMMON PEAR <i>Pyrus communis</i>		7.5m	5m	5m	3m	4m	1.8m	2m.South West.2m	Mature (M)	A mature tree situated within the field. Various broken stubs present especially on the east side at 2m. Physiological condition is good. 2 x areas of exposed wood present on the main stem on the north at 1.5m. It is likely that decay is present within the main stem in this area. The tree is surrounded by understorey vegetation which limited inspection of the main stem	No preliminary work recommended	550mm (No)	6.60	137	20-40 Years	B1
T2	SYCAMORE <i>Acer pseudoplatanus</i>		14m	5m	5m	5m	5m	4m	2.5m.South.5m	Semi-Mature (SM)	Tree is situated offsite and access was restricted to inspect. Physiological condition appears good. Tree is situated on raised ground.	No preliminary work recommended	550mm (Yes)	6.60	137	20-40 Years	B2
T3	SYCAMORE <i>Acer pseudoplatanus</i>		12m	3m	3.5m	4m	3.5m	0.5m	2m.South.2m	Mature (M)	Tree is situated on lower ground level than the site directly adjacent to road. It is multi stemmed below 1.5m and all are significantly ivy clad. Approximately five stems at present. The diameters were estimated. Epicormics are present around the main stem and tree is merging into hedge.	Recommendations: sever ivy and inspect unions	671mm (Yes)	8.10	204	20-40 Years	B2

RETENTION CATEGORY		SUB CATEGORY		SURVEY LIMITATIONS		SURVEY DETAILS											
 <p>ARBORICULTURAL CONSULTANTS</p>		<p><b>A</b> - High Quality (40 years remaining contribution)</p> <p><b>B</b> - Moderate Quality (20 years remaining contribution)</p> <p><b>C</b> - Low Quality (10 years remaining contribution)</p> <p><b>U</b> - Unsuitable for retention</p>	<p>1- Mainly Arboricultural Qualities</p> <p>2- Mainly Landscape Qualities</p> <p>3- Mainly Cultural Qualities</p> <p><b>RPA = Root Protection Area</b></p>	<p>- This tree survey is to be limited to planning purposes only.</p> <p>- This tree survey is not a tree risk assessment.</p> <p>- This survey was undertaken from ground level using visual assessment.</p> <p>- Where access was restricted attributes and dimensions were estimated.</p> <p>- The weather condition on the day of the survey was: <b>Mostly dry with light showers</b></p>	<p><b>DATE OF SURVEY-</b> 18.06.2024</p> <p><b>CLIENT-</b> Building Link Design Ltd.</p> <p><b>SITE-</b> Land at Pear Tree Farm, Brielerly, Barnsley</p> <p><b>S72 9LR</b></p> <p><b>REFERENCE-</b> 515- Tree Data Table- A</p> <p><b>SURVEYOR-</b> Rachel Selwyn</p>												
T4	SYCAMORE <i>Acer pseudoplatanus</i>		10m	3m	3m	3m	3m	0.5m	1m.South.1m	Semi-Mature (SM)	Tree is situated directly adjacent to the road within a hedgerow. It has 2 main stems joined at the base but appears to have had a break out or stem removed historically. Tree is heavily ivy clad limiting inspection. All measurements estimated. Physiological condition appears good	Recommendations: sever ivy and inspect unions	390mm (Yes)	4.80	72	10-20 Years	C2
T5	COMMON ASH <i>Fraxinus excelsior</i>		8m	3.5m	4.5m	2.5m	4m	1m	1m.South.1m	Semi-Mature (SM)	Tree is situated adjacent to the road and is situated on the edge of a banking. The tree is heavily ivy clad limiting inspection. Minor dieback is present in the crown and ivy is smothering the tree. Physiological condition is fair. recommendation sever ivy and reinspect unions.	Recommendation: sever ivy and reinspect unions	400mm (Yes)	4.80	72	10-20 Years	C2
T6	UNKNOWN		10m	3m	3m	3m	3m	2m	1m.South West.2m	Dead (D)	Tree is situated directly adjacent to the road. It is dead and is leaning towards the road. recommendation remove tree	Recommendation: Remove tree	300mm ( )	3.60	41	<10 Years	U



RETENTION CATEGORY		SUB CATEGORY		SURVEY LIMITATIONS		SURVEY DETAILS											
 <p>ARBORICULTURAL CONSULTANTS</p>		<p><b>A</b> - High Quality (40 years remaining contribution)</p> <p><b>B</b> - Moderate Quality (20 years remaining contribution)</p> <p><b>C</b> - Low Quality (10 years remaining contribution)</p> <p><b>U</b> - Unsuitable for retention</p>	<p>1- Mainly Arboricultural Qualities</p> <p>2- Mainly Landscape Qualities</p> <p>3- Mainly Cultural Qualities</p> <p>RPA = Root Protection Area</p>	<p>- This tree survey is to be limited to planning purposes only.</p> <p>- This tree survey is not a tree risk assessment.</p> <p>- This survey was undertaken from ground level using visual assessment.</p> <p>- Where access was restricted attributes and dimensions were estimated.</p> <p>- The weather condition on the day of the survey was: <b>Mostly dry with light showers</b></p>	<p>DATE OF SURVEY- 18.06.2024</p> <p>CLIENT- Building Link Design Ltd.</p> <p>SITE- Land at Pear Tree Farm, Brielerly, Barnsley</p> <p>S72 9LR</p> <p>REFERENCE- 515- Tree Data Table- A</p> <p>SURVEYOR- Rachel Selwyn</p>												
T7	COMMON ASH Fraxinus excelsior		19.2m	11m	8m	11m	11m	3.5m	5m.North.9m	Mature (M)	Tree is situated adjacent to public footpath and adjacent to offsite neighbouring properties. This is a very large mature tree. Tree has multiple pruning wounds on the east side and has been pruned away from neighbouring dwellings. Moderate deadwood is present throughout and some dieback present at the tips. This could be indicative of early Ash dieback disease. Some significant burrs are present on the main stem on all sides. Numerous cavities are present within the crown likely from old pruning wounds. Tree has high ecological value and arboricultural value due to its size and ages	No preliminary work recommended	1130mm (No)	13.50	573	40+ Years	<b>A1</b>
T8	COMMON ASH Fraxinus excelsior		18m	6m	10m	8m	4.5m	2m	7m.North West.7m	Mature (M)	A large spreading tree situated adjacent to public footpath. A large area of exposed wood is present on the main stem on southeast side at approx 1.1m. The tree has multiple broken stubs and Inonotus hispidus fungi is present on one of the stubs on the southwest side at 6m. Physiological condition overall appears quite good. Minor deadwood and dieback is present on the north side but overall not significant. Ash dieback disease could be present however. A hanging branch is present on the west side at 6m. Inspection was limited due to understory Hawthorn surrounding the stem. Tree has high ecological value and arboricultural value due to its size and ages	No preliminary work recommended	670mm (Yes)	8.10	206	40+ Years	<b>A1</b>
T9	PENDUNCULATE OAK Quercus robur l.		13m	7m		6m	5m	3m	2m.North East.5m	Semi-Mature (SM)	Tree is situated adjacent to the public footpath. It is surrounded by Holly and other vegetation therefore diameter was estimated. Physiological condition is good. Significant future growth can be expected of this tree. Tree has high future contribution potential.	No preliminary work recommended	500mm (Yes)	6.00	113	40+ Years	<b>A2</b>



		RETENTION CATEGORY					SUB CATEGORY			SURVEY LIMITATIONS			SURVEY DETAILS				
 ARBORICULTURAL CONSULTANTS		<span style="color: green;">■</span> A - High Quality (40 years remaining contribution)	1- Mainly Arboricultural Qualities		- This tree survey is to be limited to planning purposes only.			DATE OF SURVEY- 18.06.2024 CLIENT- Building Link Design Ltd. SITE- Land at Pear Tree Farm, Brierley, Barnsley S72 9LR REFERENCE- 515- Tree Data Table- A SURVEYOR- Rachel Selwyn									
		<span style="color: blue;">■</span> B - Moderate Quality (20 years remaining contribution)	2- Mainly Landscape Qualities		- This tree survey is not a tree risk assessment.												
		<span style="color: grey;">■</span> C - Low Quality (10 years remaining contribution)	3- Mainly Cultural Qualities		- This survey was undertaken from ground level using visual assessment.												
		<span style="color: red;">■</span> U - Unsuitable for retention	RPA = Root Protection Area		- Where access was restricted attributes and dimensions were estimated.												
					- The weather condition on the day of the survey was: <b>Mostly dry with light showers</b>												
T10	COMMON BEECH <i>Fagus sylvatica</i>		16m	11m	10m	9m	11m	2.5m	3m.North East.5m	Mature (M)	A large mature tree situated adjacent to public footpath. Numerous broken stubs are present with cavities within the crown. Physiological condition good. Tree is very prominent within the skyline of the local area and has high arboricultural value	0	1150mm (No)	13.80	598	40+ Years	A1
T11	SYCAMORE <i>Acer pseudoplatanus</i>		11m	3.5m	4.5m	5m	3.5m	2m	2.5m.South.4m	Semi-Mature (SM)	Tree is growing on an edge of a group of trees which are situated in the offsite church grounds. The tree is onsite. Future growth can be expected of this tree. Physiological condition is good.	No preliminary work recommended	400mm (Yes)	4.80	72	20-40 years Years	B2
T12	SYCAMORE <i>Acer pseudoplatanus</i>		12m	5m	3m	3m	3m	3m	2.5m.North.3m	Semi-Mature (SM)	Tree is situated towards frontage of site and branches overhang main road. Physiological condition is good. Epicormics are present around base hindering inspection.Future growth can be expected of this tree.	No preliminary work recommended	450mm (Yes)	5.40	92	20-40 Years	B2



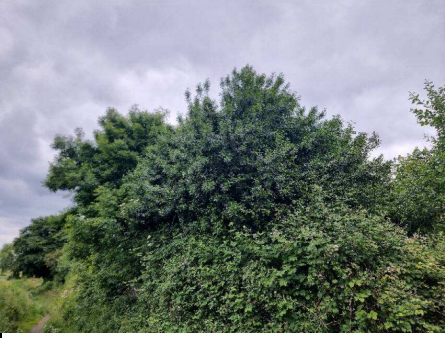

RETENTION CATEGORY		SUB CATEGORY		SURVEY LIMITATIONS		SURVEY DETAILS										
 <p>ARBORICULTURAL CONSULTANTS</p>		<p><b>A</b> - High Quality (40 years remaining contribution)</p> <p><b>B</b> - Moderate Quality (20 years remaining contribution)</p> <p><b>C</b> - Low Quality (10 years remaining contribution)</p> <p><b>U</b> - Unsuitable for retention</p>	<p>1- Mainly Arboricultural Qualities</p> <p>2- Mainly Landscape Qualities</p> <p>3- Mainly Cultural Qualities</p> <p><b>RPA = Root Protection Area</b></p>	<p>- This tree survey is to be limited to planning purposes only.</p> <p>- This tree survey is not a tree risk assessment.</p> <p>- This survey was undertaken from ground level using visual assessment.</p> <p>- Where access was restricted attributes and dimensions were estimated.</p> <p>- The weather condition on the day of the survey was: <b>Mostly dry with light showers</b></p>	<p><b>DATE OF SURVEY</b>- 18.06.2024</p> <p><b>CLIENT</b>- Building Link Design Ltd.</p> <p><b>SITE</b>- Land at Pear Tree Farm, Brielerly, Barnsley</p> <p><b>S72 9LR</b></p> <p><b>REFERENCE</b>- 515- Tree Data Table- A</p> <p><b>SURVEYOR</b>- Rachel Selwyn</p>											
T13	SYCAMORE <i>Acer pseudoplatanus</i> 	14m	5m	4m	6m	5m	2m	2.5m.West.3m	Semi-Mature (SM)	Tree is growing as part of a group of trees and is affected by group pressure. Physiological condition is good. Epicormics are present around base limiting inspection and measurement. Access was restricted to inspect tree and all measurements were estimated	No preliminary work recommended	550mm (Yes)	6.60	137	20-40 Years	B2
T14	COMMON LIME <i>Tilia x europaea</i> 	15m	5m	5m	3m	5m	0.3m	2m.North.5m	Semi-Mature (SM)	Tree is growing as part of a group of trees and is the end tree of the group. Access was restricted to inspect. Tree appears to be in good physiological condition and has good positive amenity value as part of a group	No preliminary work recommended	550mm (Yes)	6.60	137	40+ Years	A2
										End of Tree data						

RETENTION CATEGORY		SUB CATEGORY		SURVEY LIMITATIONS		SURVEY DETAILS	
	A - High Quality (40 years remaining contribution)	1- Mainly Arboricultural Qualities	- This tree survey is to be limited to planning purposes only.	- This tree survey is to be limited to planning purposes only. - This tree survey is not a tree risk assessment. - This survey was undertaken from ground level using visual assessment. - Where access was restricted attributes and dimensions were estimated. - The weather condition on the day of the survey was: <b>Mostly dry with light showers</b>		DATE OF SURVEY- 18.06.2024	
	B - Moderate Quality (20 years remaining contribution)	2- Mainly Landscape Qualities				CLIENT- Building Link Design Ltd.	
	C - Low Quality (10 years remaining contribution)	3- Mainly Cultural Qualities				SITE- Land at Pear Tree Farm, Brierley, Barnsley	
	U - Unsuitable for retention	RPA = Root Protection Area				S72 9LR	
SELWYNTREES ARBORICULTURAL CONSULTANTS						REFERENCE- 515- Tree Data Table- A	
						SURVEYOR- Rachel Selwyn	





### BS5837:2012 Group Data Table - See Associated Tree Constraints Plan for Group Crown Spread & RPA Calculations



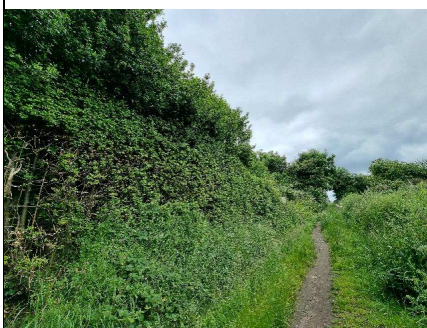

Group No.	Tree Species Common & Latin Name	Landscape Photos of Tree Group	Min Height	Max height	Age Class	Comments- Tree location/Condition/ Landscape Significance	Initial Recommendations	Tree Trunk Diameter at 1.5m Average	Height of Crown Clearance (m)	Estimated Remaining Contribution	BS5837 Retention Category
G1	A mixed group of offsite trees consisting of Sycamore ( <i>Acer pseudoplatanus</i> ), Ash ( <i>Fraxinus excelsior</i> ) and Hawthorn ( <i>Crataegus monogyna</i> ).		4m	11m	Semi-mature	A mixed group of offsite trees consisting of sycamore ash hawthorn. Maximum diameter 200mm. Branches overhang the public footpath and boundary by around 5m. Physiological condition appears good. Ivy appears prevalent throughout. Inspection was limited to inspect	No preliminary work recommended	200mm	1m	20-40 Years	B2
G2	A Group of offsite trees situated in neighbouring church grounds. Species consist of Cherry ( <i>Prunus avium</i> ), Ash ( <i>Fraxinus excelsior</i> ) and Sycamore ( <i>Acer pseudoplatanus</i> )		3m	14m	Semi-mature to mature	A Group of offsite trees situated in neighbouring church grounds. Species consist of Cherry ( <i>Prunus avium</i> ), Ash ( <i>Fraxinus excelsior</i> ) and Sycamore ( <i>Acer pseudoplatanus</i> ). The group borders the site and sections overhang the site. Size is variable. The maximum stem diameter was estimated as 400mm. Physiological condition appears good and groups provides good amenity and screening value within the local area.	No preliminary work recommended	400mm	1m	20-40 Years	B2
G3	A group of three Apple <i>Malus</i> spp. trees		4m	5m	Mature	A group of three trees. maximum 5. minimum height 4.average diameter 250mm. physiological condition good	No preliminary work recommended	250mm (average)	1.4m	10-20 Years	C2

RETENTION CATEGORY		SUB CATEGORY		SURVEY LIMITATIONS				SURVEY DETAILS				
 <p>ARBORICULTURAL CONSULTANTS</p>		<p><b>A</b> - High Quality (40 years remaining contribution)</p> <p><b>B</b> - Moderate Quality (20 years remaining contribution)</p> <p><b>C</b> - Low Quality (10 years remaining contribution)</p> <p><b>U</b> - Unsuitable for retention</p>	<p>1- Mainly Arboricultural Qualities</p> <p>2- Mainly Landscape Qualities</p> <p>3- Mainly Cultural Qualities</p> <p><b>RPA = Root Protection Area</b></p>		<p>- This tree survey is to be limited to planning purposes only.</p> <p>- This tree survey is not a tree risk assessment.</p> <p>- This survey was undertaken from ground level using visual assessment.</p> <p>- Where access was restricted attributes and dimensions were estimated.</p> <p>- The weather condition on the day of the survey was: <b>Mostly dry with light showers</b></p>				<p><b>DATE OF SURVEY</b>- 18.06.2024</p> <p><b>CLIENT</b>- Building Link Design Ltd.</p> <p><b>SITE</b>- Land at Pear Tree Farm, Brielerly, Barnsley</p> <p><b>S72 9LR</b></p> <p><b>REFERENCE</b>- 515- Tree Data Table- A</p> <p><b>SURVEYOR</b>- Rachel Selwyn</p>			
G4	A group of approximately three trees consisting of one pine and two leylandii		6.5m	7.5m	young to semi-mature	A group of approximately three trees consisting of one pine and two leylandii. Minimum height. 6.5m. maximum height 7.5m. All are relatively young. Currently, physiological condition is good. Future growth can be expected of all. diameter of pine estimated as 300mm.	No preliminary work recommended	300mm	0.3m	20-40 Years	B2	
0						End of Group Data						
0												

RETENTION CATEGORY		SUB CATEGORY		SURVEY LIMITATIONS		SURVEY DETAILS	
	A - High Quality (40 years remaining contribution)	1- Mainly Arboricultural Qualities	- This tree survey is to be limited to planning purposes only.	- This tree survey is to be limited to planning purposes only. - This tree survey is not a tree risk assessment. - This survey was undertaken from ground level using visual assessment. - Where access was restricted attributes and dimensions were estimated. - The weather condition on the day of the survey was: <b>Mostly dry with light showers</b>		<b>DATE OF SURVEY-</b> 18.06.2024 <b>CLIENT-</b> Building Link Design Ltd. <b>SITE-</b> Land at Pear Tree Farm, Brierley, Barnsley <b>S72 9LR</b> <b>REFERENCE-</b> 515- Tree Data Table- A <b>SURVEYOR-</b> Rachel Selwyn	
	B - Moderate Quality (20 years remaining contribution)	2- Mainly Landscape Qualities					
	C - Low Quality (10 years remaining contribution)	3- Mainly Cultural Qualities					
	U - Unsuitable for retention	RPA = Root Protection Area					
 ARBORICULTURAL CONSULTANTS							

## BS5837:2012 Hedgerow Data Table - See Associated Tree Constraints Plan for Hedgerow Crown Spread & RPA Calculations

Hedge No.	Photo of Hedgerow	Tree Species Common & Latin Name	Percentage	Min Height	Max Height	Width	Age Class	Comments- Tree location/Condition/ Landscape Significance	Initial Recommendations	Tree Trunk Diameter at 1.5m Minimum & Maximum	Estimated Remaining Contribution	BS5837 Retention Category
H1		HAWTHORN <i>Crataegus monogyna</i>	70%	3m	8m	2m	Semi-mature	A hedgerow , which runs down the boundary of the field. Larger Sycamore and ash trees are present emedded within the hedge. Physiological condition good. Hedge has screening and wildlife value	No preliminary work recommended.	100mm	20-40 Years	B2
		COMMON ASH <i>Fraxinus excelsior</i>	10%									
		ELM - WYCH ELM <i>Ulmus glabra</i>	10%									
		00:00:00	0									
		00:00:00	0									
H2		PENDUNCULATE OAK <i>Quercus robur</i> l.	30%	1.5m	2.5m	2m	Semi- mature	A hedgerow which runs through the site which appears to have been maintained historically. The hedge varies in height and consists mostly of these species . The hedgerow is broken and gaps are present in places. Hedge has screening and wildlife value	No preliminary work recommended.	150mm	10-20 Years	C2
		SYCAMORE <i>Acer pseudoplatanus</i>	40%									
		HAWTHORN <i>Crataegus monogyna</i>	30%									
		0	0									
		0	0									
H3		HAWTHORN <i>Crataegus monogyna</i>	50%	2m	7m	4m	Semi-mature	A broken hedgerow extending down the boundary, consisting mostly of Hawthorn Holly. Lower sections have been maintained and cut back from public footpath. Physiological condition appears generally good d	No preliminary work recommended.	90mm	20-40 Years	B2
		HOLLY <i>Ilex aquifolium</i>	50%									
		0	0									
		0	0									
		0	0									
H4		HAWTHORN <i>Crataegus monogyna</i>	0.5	1.6m	2.5m	2m	Semi- Mature	A hedgerow consisting mostly of Hawthorn and Sycamore with brambles present. Other ground vegetation also presnet. Hedge has some screening and wildlife value.	No preliminary work recommended.	90mm	20-40 Years	B2
		SYCAMORE <i>Acer pseudoplatanus</i>	0.5									
		0	0									
		0	0									
		0	0									

RETENTION CATEGORY		SUB CATEGORY		SURVEY LIMITATIONS				SURVEY DETAILS													
								DATE OF SURVEY- 18.06.2024	CLIENT- Building Link Design Ltd.	SITE- Land at Pear Tree Farm, Brielerly, Barnsley S72 9LR	REFERENCE- 515- Tree Data Table- A	SURVEYOR- Rachel Selwyn									
 <p>ARBORICULTURAL CONSULTANTS</p>		<p><b>A</b> - High Quality (40 years remaining contribution)</p> <p><b>B</b> - Moderate Quality (20 years remaining contribution)</p> <p><b>C</b> - Low Quality (10 years remaining contribution)</p> <p><b>U</b> - Unsuitable for retention</p>	<p>1- Mainly Arboricultural Qualities</p> <p>2- Mainly Landscape Qualities</p> <p>3- Mainly Cultural Qualities</p> <p>RPA = Root Protection Area</p>	<p>- This tree survey is to be limited to planning purposes only.</p> <p>- This tree survey is not a tree risk assessment.</p> <p>- This survey was undertaken from ground level using visual assessment.</p> <p>- Where access was restricted attributes and dimensions were estimated.</p> <p>- The weather condition on the day of the survey was: <b>Mostly dry with light showers</b></p>																	
H5		<table border="1"> <tr><td>HAWTHORN Crataegus monogyna</td><td>0.9</td></tr> <tr><td>SYCAMORE Acer pseudoplatanus</td><td>0.05</td></tr> <tr><td>HOLLY Ilex aquifolium</td><td>0.05</td></tr> <tr><td>0</td><td>0</td></tr> <tr><td>0</td><td>0</td></tr> </table>	HAWTHORN Crataegus monogyna	0.9	SYCAMORE Acer pseudoplatanus	0.05	HOLLY Ilex aquifolium	0.05	0	0	0	0	1.7m	6m	3.5m	Semi-mature and mature	A double staggered hedgerow, consisting mostly of Hawthorn, which run either side of a public footpath. Some Holly also present within the hedgerow. Good physiological condition and hedge has some screening and wildlife value.	No preliminary work recommended at time of survey.	100mm	20-40 Years	B2
HAWTHORN Crataegus monogyna	0.9																				
SYCAMORE Acer pseudoplatanus	0.05																				
HOLLY Ilex aquifolium	0.05																				
0	0																				
0	0																				
H6		<table border="1"> <tr><td>HOLLY Ilex aquifolium</td><td>70%</td></tr> <tr><td>HAWTHORN Crataegus monogyna</td><td>20%</td></tr> <tr><td>ELDER Sambucus nigra</td><td>10%</td></tr> <tr><td>0</td><td>0</td></tr> <tr><td>0</td><td>0</td></tr> </table>	HOLLY Ilex aquifolium	70%	HAWTHORN Crataegus monogyna	20%	ELDER Sambucus nigra	10%	0	0	0	0	2.5m	5m	4m	Semi mature	A mixed hedgerow consisting mostly of Holly, extending down the boundary. Hawthorn, Elder and Brambles also present. Good physiological condition and hedge has some screening and wildlife value.	No preliminary work recommended at time of survey.	90mm	20-40 Years	B2
HOLLY Ilex aquifolium	70%																				
HAWTHORN Crataegus monogyna	20%																				
ELDER Sambucus nigra	10%																				
0	0																				
0	0																				
H7		<table border="1"> <tr><td>HAWTHORN Crataegus monogyna</td><td></td></tr> <tr><td>0</td><td>0</td></tr> <tr><td>0</td><td>0</td></tr> <tr><td>0</td><td>0</td></tr> <tr><td>0</td><td>0</td></tr> </table>	HAWTHORN Crataegus monogyna		0	0	0	0	0	0	0	0	2.4m	2.6m	0.6m	Semi-mature to mature	A well maintained Hawthorn hedgerow, with ivy, extending along the frontage of the site. Hedge provides valuable screening and amenity valye between the road and the site	No preliminary work recommended at time of survey.	50mm	20-40 Years	B2
HAWTHORN Crataegus monogyna																					
0	0																				
0	0																				
0	0																				
0	0																				
							End of Hedge Data														

## Landscape context images.



*Photo 1; Looking North towards G4 and hedge H7*



*Photo 2: Looking Northeast towards Hedge H7, with trees T12, T13 and T14 to the right, and group G4 to the left*



*Photo 3: Looking North towards trees T12, T13 and T14.*



Photo 4: Looking Southeast

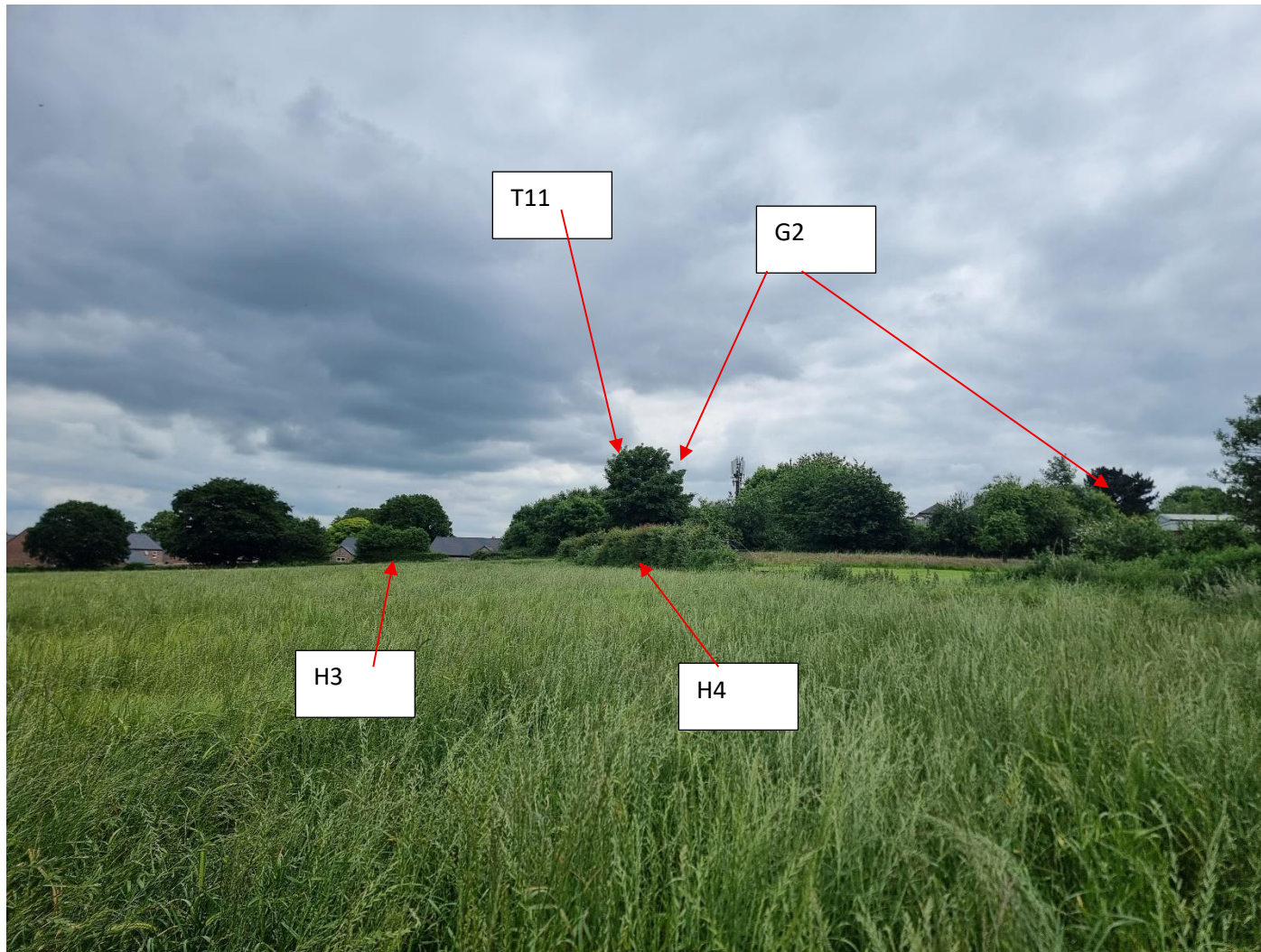

*Photo 5: Looking Southeast from agricultural field.*



*Photo 6: Looking Southeast from agricultural fields*

H6



*Photo 7: Looking South towards H6*

## 6 Tree Constraints Plan:

According to the LANDIS Soilscape interactive soils map (Cranfield Soil and Agrifood Institute 2024), the soil type in the area of the site is "Freely draining slightly acid loamy soils"

"Slowly permeable seasonally wet acid loamy and clayey soils" are present in the northwest of the adjacent field to Pera Tree Farm. (Cranfield Soil and Agrifood Institute 2024)

According to the Interactive Map on the Barnsley Metropolitan Borough Council website, trees T12, T13 and T14 are protected by a group TPO, (TPO reference number 12: G1.)

Pear Tree Farm is within a Conservation Area

Trees are referenced as T(n)  
Groups are referenced as G(n)  
Hedges are referenced as H(n)

RPAs (Root Protection Areas) are illustrated by grey hatched polygon areas

For groups the illustrated RPAs were approximated.  
Crown spreads are illustrated by green, blue, grey or red outlines depending on the retention category of the tree, group or hedgerow.

**SELWYNTREES**  
TRAINED. QUALIFIED. TRUSTED.

30 Tickhill Road Doncaster  
South Yorkshire DN4 8QE  
01302 816850  
info@selwyntrees.co.uk

**Tree Constraints Plan 1:400, Land at Pear Tree Farm, Brierley, Barnsley S72 9JR**

SCALE : 1 : 400	@ A3	DATE : 05/07/2024	
MAP FILENAME : TCP 1:400 A3- Land at Pear Tree Farm Brierley, Barnsley			

Map data shown may contain Ordnance Survey © products supplied by Pear Technology Services Ltd; Email: info@peartechology.co.uk  
© Crown Copyright and database rights from date shown above  
Ordnance Survey © licence number 100023148

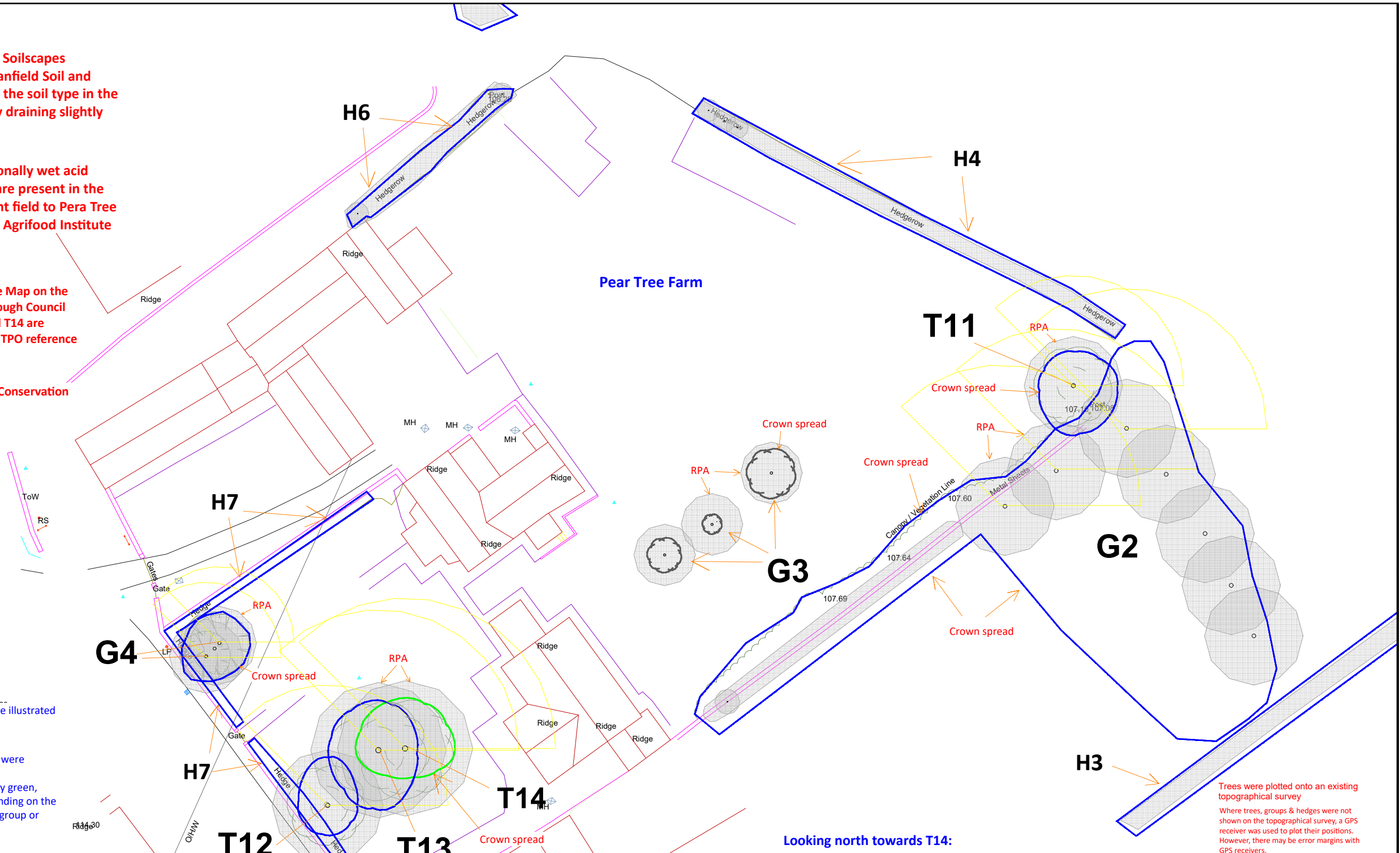

Within RPAs of trees there must be no excavation, no soil piling, no storage of materials, no spillage of construction waste and no spoil thrown out on or near RPAs. The soil within RPAs must not be compacted.

The default position as outlined in BS5837:2012 is that all new development should be located outside of RPAs, and crown spreads of trees to be retained.

All new utilities and service runs need to be located outside of RPAs of retained trees.

Looking north towards T14:



Trees were plotted onto an existing topographical survey  
Where trees, groups & hedges were not shown on the topographical survey, a GPS receiver was used to plot their positions. However, there may be error margins with GPS receivers.  
Do not scale from these drawings. All measurements should be checked on site. If in doubt, ask.

Tree Number  
Shading Arc  
Root Protection Area  
Crown Spread

Category 'A' Category 'B' Category 'C' Category 'U'

0 20m

## 7 Arboricultural Impacts Plan:

## Summary of Arboricultural Impacts

Trees to be removed to accommodate proposal:

- G3 = 3 x trees
- 9.5m + 34.7m of Hedge H7
- 7m of H4- for access road for Phase 2

Pruning:  
G4= Tip reduction pruning on North/Northwest side by up to 1.5m to accommodate scaffolding access.

### Encroachment into RPAs by new pavements, access road:

- T12: 9.2m<sup>2</sup> = 10% of Total RPA
- T13: 14.8m<sup>2</sup> = 10.8% of Total RPA
- T14: 0.64m<sup>2</sup> = 0.5% of Total RPA

G1:  
Total RPA of each tree within G1 (Based on stem diameter per tree of 300mm) = 41m<sup>2</sup>  
Southwestern tree in G1= 10.7m<sup>2</sup> = 26.1%  
Middle tree within G4: 8.8m<sup>2</sup> = 21.5%  
Northeastern tree of G4: 5.7m<sup>2</sup> = 13.9%

Dropped kerbs:  
Two sections of dropped kerbs would require excavating in order to remove existing pavements to create the widened access way. These are within the RPAs of T12 and one tree within G4

The encroachments of these dropped kerbs into the RPAs is relatively minor:  
T12= 1.8m<sup>2</sup> = 2% of total RPA  
0.5m<sup>2</sup> = 1.2% of the Southwestern tree within G4.

Plot 1 would be 0.4m from the RPA of T14  
Plot 2 would be 0.5m from the RPA of G4  
Some overspill encroachment may occur into these RPAs as a result of excavation for traditional strip footing foundations. This may result in root severing/ damage occurring.

To lessen the likelihood of root damage occurring, Air excavation should be used to excavate for these sections of foundations closest to the RPAs of T14 and G4.

### Access within RPAs:

Access would be required within the RPAs of T14 and G4, in order to excavate for the foundations and accommodate scaffolding

Temporary ground protection is required in these areas. This will minimise compaction damage to the soil within RPAs, by spreading the loading of traffic on the soil.

### Potential Pressure to Prune/ Remove conflicts:

- T11 and Plot 6
- G2 and plots 6, 7, 8, 9 and 10
- T14 and Plot 1
- G4 and Plot 2

Trees were plotted onto an existing topographical survey  
Where trees, groups & hedges were not shown on the topographical survey, a GPS receiver was used to plot their positions. However, there may be error margins with GPS receivers.

Do not scale from these drawings. All measurements should be checked on site, if in doubt, ask.

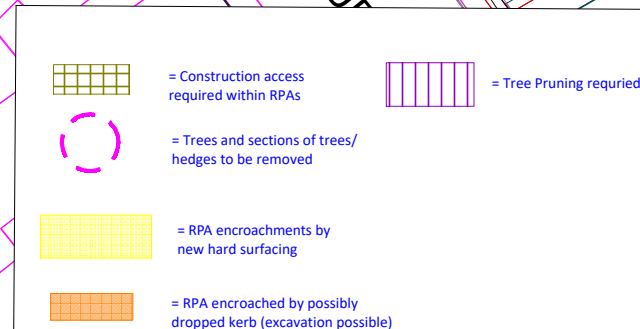
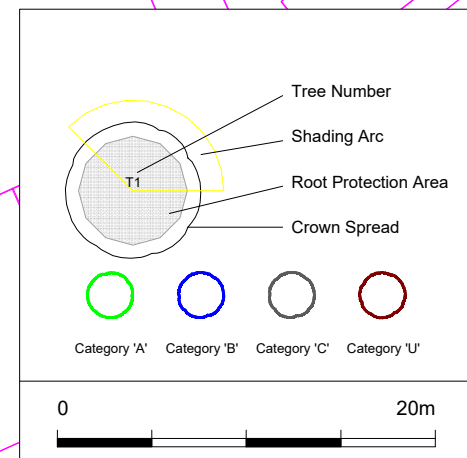

Trees are referenced as T(n)  
Groups are referenced as G(n)  
Hedges are referenced as H (n)

RPAs (Root Protection Areas) are illustrated by grey hatched polygon areas  
For groups the illustrated RPAs were approximated.  
Crown spreads are illustrated by green, blue, grey or red outlines depending on the retention category of the tree, group or hedgerow.

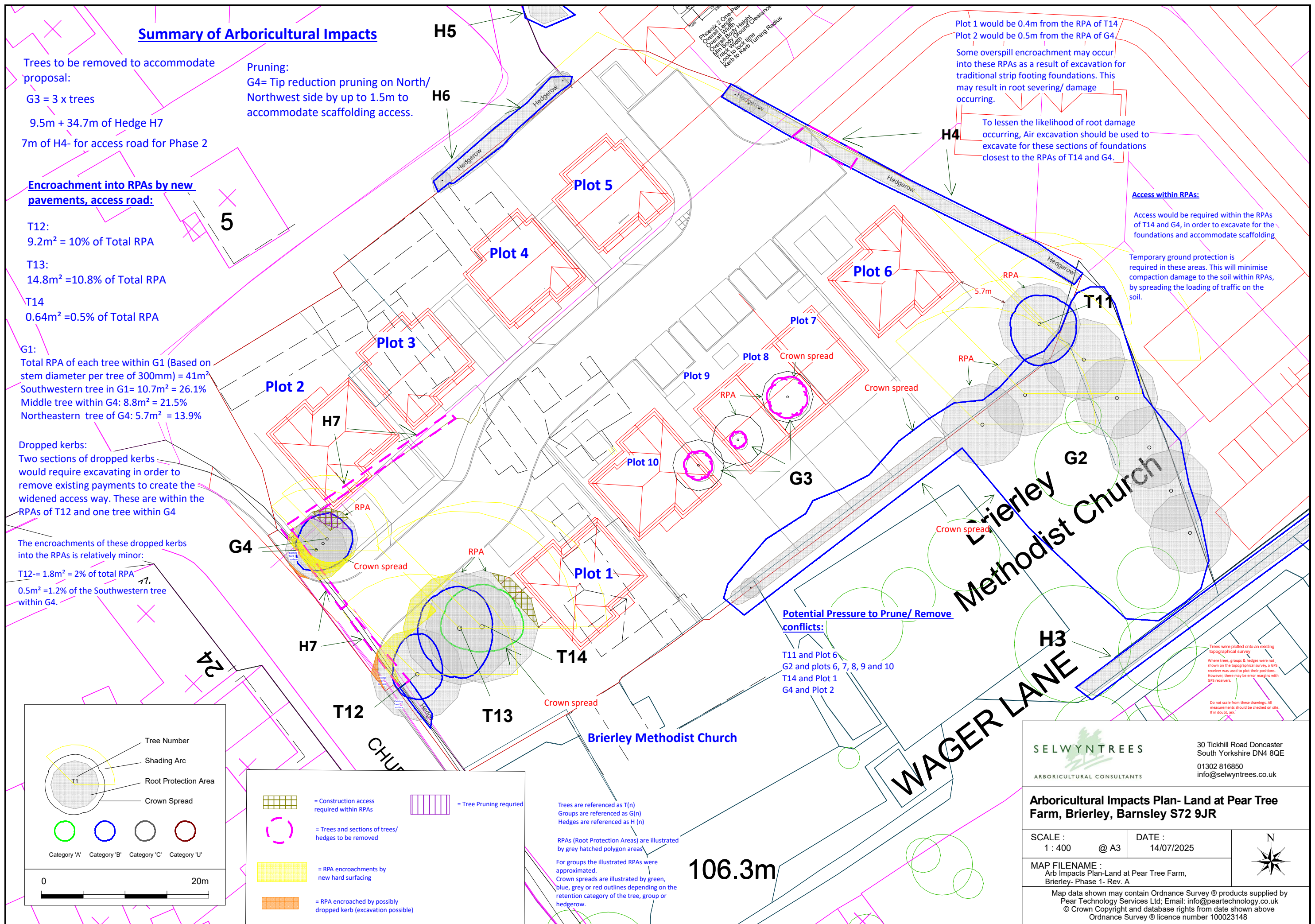

**SELWYNTREES**  
ARBORICULTURAL CONSULTANTS

30 Tickhill Road Doncaster  
South Yorkshire DN4 8QE  
01302 816850  
info@selwyntrees.co.uk

**Arboricultural Impacts Plan- Land at Pear Tree Farm, Brierley, Barnsley S72 9JR**

SCALE : 1 : 400 @ A3      DATE : 14/07/2025

MAP FILENAME : Arb Impacts Plan-Land at Pear Tree Farm, Brierley- Phase 1- Rev. A

Map data shown may contain Ordnance Survey © products supplied by Pear Technology Services Ltd; Email: info@peartechology.co.uk  
© Crown Copyright and database rights from date shown above  
Ordnance Survey © licence number 100023148

## 8 Outline Tree Protection Plan:

Figure 1: Tree Protection Fencing to be used, as per BS5837:2012:

Example of Rigid Style Heras fencing:

Default specification for protective barrier as per British Standard BS 5837:2012 - Trees in relation to Design, Demolition and Construction

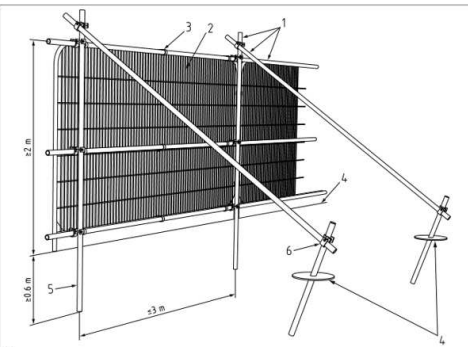

- Key
- 1 Standard scaffold poles
  - 2 Heavy gauge 2 m tall galvanized tube and welded mesh infill panels
  - 3 Panels secured to uprights and cross-members with wire ties
  - 4 Ground level
  - 5 Uprights driven into the ground until secure (minimum depth 0.6 m)
  - 6 Standard scaffold clamps

**Excavation for Foundations Close to RPAs:**

To lessen the likelihood of root damage occurring, Air excavation should be used to excavate for these sections of foundations closest to the RPAs of T14 and G4.

Figure 2: Photo of Air excavation in action @ Selwyn Trees:



**Dropped kerbs:**  
Two sections of dropped kerbs would require excavating in order to remove existing payments to create the widened access way. These are within the RPAs of T12 and one tree within G4

**Site Logistics**

Construction worker parking shall be onsite, likely accessed via Church Street.

Material storage shall be onsite, outside of tree protection fencing. Materials shall not be stored within RPAs on site.

Any skips shall likely be located towards the front of the site

A welfare unit shall be located on site situated outside of all tree protection fencing.

Table 1: Specification for Temporary Ground Protection Boards (Ground Guards) based on load requirements:

Traffic	Gross weight	Ground Protection Boards	Layers of boards	Compression layer	Membrane
Pedestrians only		GroundGuards MultiTrack	1	100mm woodchip	Geotextile
Pedestrian plant	Up to 2 t	GroundGuards MultiTrack	1	150mm woodchip	Geotextile
Vehicular plant	2 - 10 t	GroundGuards MultiTrack	2	150mm woodchip	Geotextile
Vehicular plant	10 - 20t	GroundGuards MaxiTrack	2	150mm woodchip	Geotextile
Vehicular plant	Over 20 t	GroundGuards XtremeMats	1	150mm woodchip	Geotextile

Figure 3: Example of Temporary Ground Protection Boards (GroundGuards) with membrane and woodchip layer:



**CEZ= Construction Exclusion Zone**

Within The CEZ, the following is PROHIBITED:

- Access by pedestrians,
- Access by construction plant
- Access by vehicles
- Storage of construction materials
- Storage of Demolition Debris
- Construction Worker Parking
- Mixing, refuelling, spoil being tipped within it.

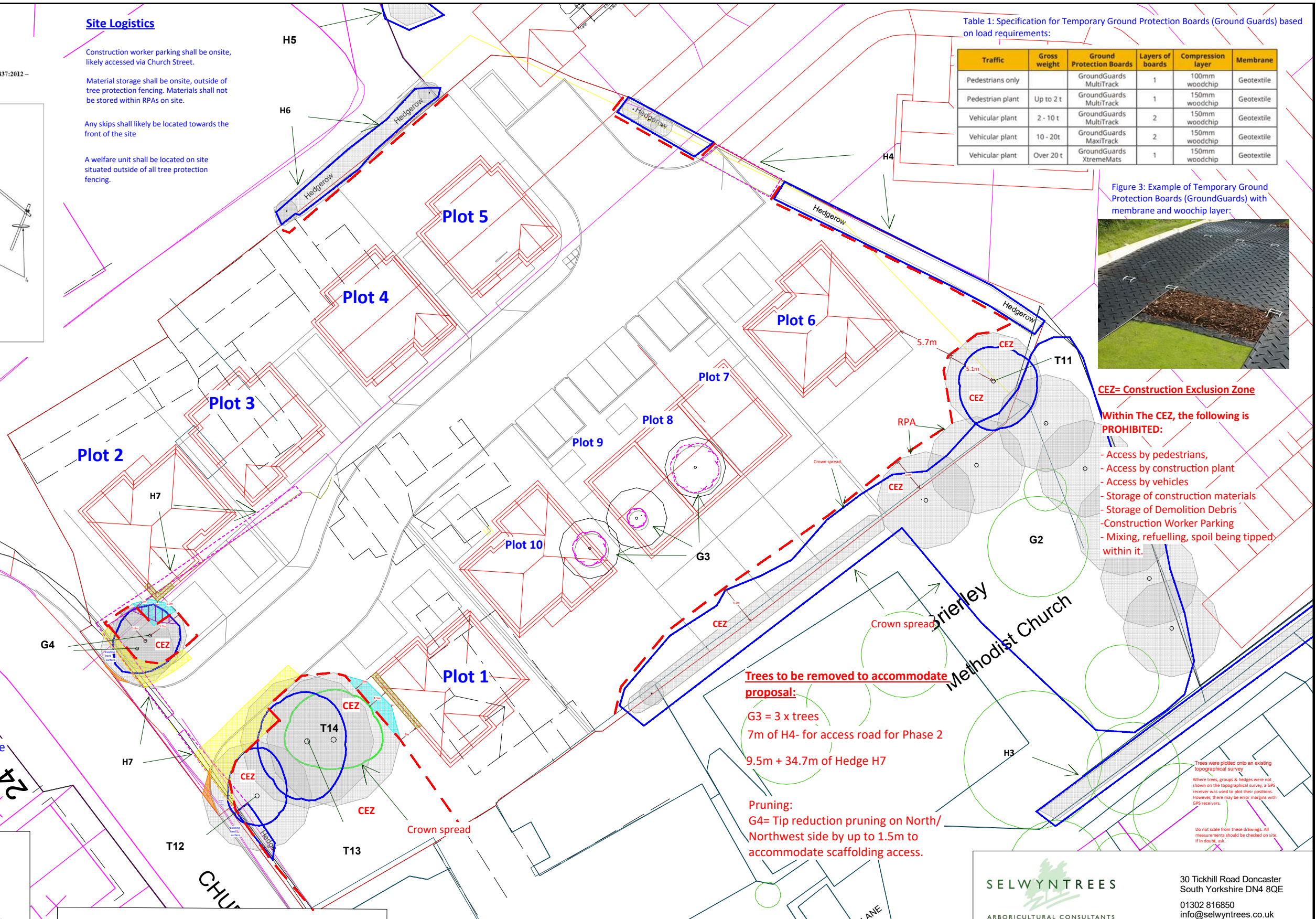

**Trees to be removed to accommodate proposal:**  
G3 = 3 x trees  
7m of H4- for access road for Phase 2  
9.5m + 34.7m of Hedge H7

**Pruning:**  
G4= Tip reduction pruning on North/Northwest side by up to 1.5m to accommodate scaffolding access.

Figure 4: Indicative Cellweb TRP system with overfill:

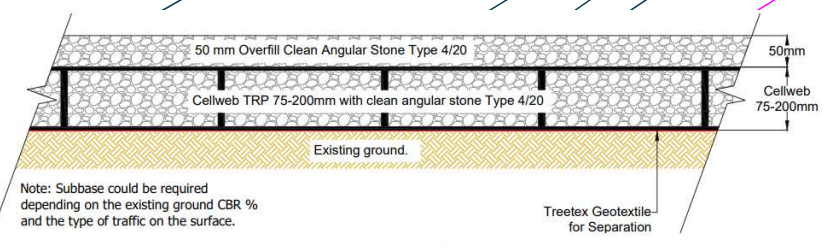

Note: Subbase could be required depending on the existing ground CBR % and the type of traffic on the surface.

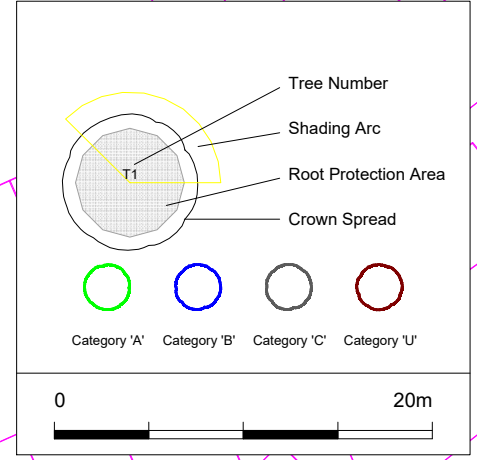

- [Grid pattern] = Sections of Foundations to be excavated using Air Excavation to minimise overspill into RPAs:
- [Dashed circle] = Trees and sections of trees/hedges to be removed
- [Yellow grid] = No-dig Load-bearing porous cellular confinement system (Eg Cellweb TRP)
- [Orange grid] = RPA encroached by possible dropped kerb (excavation possible)
- [Vertical lines] = Tree Pruning required
- [Blue grid] = Temporary Ground Protection
- [Red dashed line] = Tree Protection fencing

Trees are referenced as T(n)  
Groups are referenced as G(n)  
Hedges are referenced as H (n)

RPAs (Root Protection Areas) are illustrated by grey hatched polygon areas

For groups the illustrated RPAs were approximated.  
Crown spreads are illustrated by green, blue, grey or red outlines depending on the retention category of the tree, group or hedgerow.

Trees were plotted onto an existing topographical survey  
Where trees, groups & hedges were not shown on the topographical survey, a GPS receiver was used to plot their positions. However, there may be error margins with GPS receivers.  
Do not scale from these drawings. All measurements should be checked on site, if in doubt, ask.

**SELWYN TREES**  
ARBORICULTURAL CONSULTANTS

30 Tickhill Road Doncaster  
South Yorkshire DN4 8QE  
01302 816850  
info@selwyntrees.co.uk

**Outline Tree Protection Plan -Pear Tree Farm, Brierley, Barnsley S72 9JR**

SCALE: 1 : 400 @ A3  
DATE: 16/07/2025

MAP FILENAME: Outline TPP-Land at Pear Tree Farm, Brierley- Phase 1- Rev. A

Map data shown may contain Ordnance Survey © products supplied by Pear Technology Services Ltd; Email: info@peartechology.co.uk  
© Crown Copyright and database rights from date shown above  
Ordnance Survey © licence number 100023148

## 9 Arboricultural Impact Assessment

9.1.1 The proposal is for the demolition of the existing dwelling and farm buildings on the site and to construct 10 new dwellings. The proposal includes creating a new access way into the site from Church Street, with new dropped kerbs. The proposal assessed in this Impact Assessment is as shown in the drawing referenced as “4038-03b”.

### Direct conflicts and Impacts

Tree removals and pruning for development:

Table 2- Tree Work required to accommodate and facilitate proposed development

Tree	Category	Work required pre – commencement of proposal	Work required during development	Work required post development
G3	C2	Remove three trees within this group including stumps	N/A	N/A
H7	B2	Remove 9.5m and 34.7m of this hedge including stumps	N/A	None
H4	B2	Remove a 7m Section of this hedge including stumps	None	None
G4	B2	Tip reduction pruning on North/ Northwest side by up to 1.5m to accommodate scaffolding access.	None	None
T264	B1	None	None	None
T2	B2	None	None	None
T3	B2	None	None	
T4	C2	None	None	None
T5	C2	None	None	None
T6	U	None	None	None
T7	A1	None	None	None
T8	A1	None	None	None
T9	A2	None	None	None
T10	A1	None	None	None
T11	B2	None	None	None
T12	B2	None	None	None
T13	B2	None	None	None
T14	A2	None	None	None
G1	B2	None	None	None
G2	B2	None	None	None
H1	B2	None	None	None
H2	C2	None	None	None
H3	B2	None	None	None
H5	B2	None	None	None
H6	B2	None	None	None

- 9.1.2 Three trees within group G3 require removing to accommodate this proposal.
- 9.1.3 These are Apple trees, assigned retention Category C. They are not particularly prominent or visible from local area, therefore their removal is unlikely to detrimentally affect the amenity value of the local area.
- 9.1.4 A large section of Hedge H7 is to be removed to accommodate the new access road into the site from Church Street. The hedge currently does provide some amenity value for the road Church Street. The loss of a large section of this hedge will impact the green amenity value of the site and Church Street. However, trees within group G4 and T12, T13 and T14 are to be retained. These trees will maintain amenity and skyline value of the local area.
- 9.1.5 A section of hedge H4 is to be removed, to accommodate the access road to the Northeast. This hedge has wildlife and some green amenity value. Removing a small section is unlikely to be significantly detrimentally affect the amenity of the local area.

#### **Future pressure to prune or remove trees**

##### **T11**

- 9.1.6 Tree T11 is a semi mature Sycamore tree and the RPA would be around 5.7m from the corner of a proposed dwelling. The tree T11 would be around 10.6m from the corner of the nearest proposed dwelling, measured from the main stem.
- 9.1.7 This tree can be expected to grow larger in height and in spread. Sycamore trees are known to drop sap and debris such as leaves and seeds. They also can create heavy shade which impacts the ability to grow lawn and amenity plants beneath them. Hence, occupiers often have conflict with Sycamore trees. The distance between the tree T11 and the corner of the proposed dwelling is currently adequate (10.6m) but there may be a pressure to prune/ remove the tree by the future occupiers as it grows larger and extends over the garden and towards the dwelling.
- 9.1.8 The canopy spread of T11 Sycamore is around 3.5m on the Northwest side. This can be expected to reach 8m in maturity. Pruning would help maintain the tree at its current size. However, this would be a long term repeated fiscal expense for the future occupiers.

##### **G2**

- 9.1.9 G2 consists of an offsite group of trees mostly consisting of Cherry, Ash and Sycamore. The group is mature and branches overhang into the site by up to 4m currently. Some future pruning may be desired by the future occupiers of plots 6, 7, 8, 9 and 10, to maximise the usability of their garden.
- 9.1.10 Garden plants including grass can struggle to establish underneath the canopies of trees due to the shade cast by them. Its possible such pruning on the Northwest sides may result in trees within G2 appearing unbalanced.

- 9.1.11 G2 would cast shade over the rear gardens of plots 6, 7, 8, 9 and 10. This may result in conflict between the future occupiers of the proposed and the owners of these trees, Brierley Methodist Church. In order to use the rear gardens, the future occupiers may desire and request that the trees be reduced or removed in order to allow more light into the gardens, and to prevent debris such as leaves, collecting in the gardens.
- 9.1.12 Ideally the dwellings on plots 6-10 would have greater distance between them and trees within G2 and T11, to reduce potential long term future conflicts as they continue to grow larger. This would also reduce the potential fiscal costs of pruning to manage overhang for the future occupiers. Pruning in the future will realistically be required as the trees continue to grow over the gardens. Using gutter guards may help reduce some nuisance conflict by reducing the regularity of tree debris blocking the gutters.

#### **T14**

- 9.1.13 The crown of tree T14, Category A, (Lime) would be around 2m from the proposed dwelling on plot 1. Future growth can be expected of this tree and it can be expected to form a large tree in maturity. If is prominent as part of a group with trees T12 and T13.
- 9.1.14 Pruning would likely be required in the future to manage the clearance between the branches of this tree and the dwelling. This would likely result in future repeated fiscal maintenance costs for the future occupiers. Another potential impact may be a desire to remove the tree due to the nuisance and expense of the proximity of this tree to the property, as it grows larger.
- 9.1.15 This tree can be expected to ultimately reach a height of 20m+. At around 6.9m from the dwelling on plot 1, it is possible future occupiers will have high anxiety regarding this tree at this distance from the property, and desire to remove it as a result.

#### **G4**

- 9.1.16 This group consists of 1 x Pine and 2 x Leylandii. Significant future growth can be expected of all. The Leylandii are the closest trees to the proposed dwelling on plot 2. These can be expected to form large trees if not reduced and maintained.
- 9.1.17 As a group, these trees provide some green skyline value for the area. As individuals, the Leylandii do not have particularly high Arboricultural value. Pruning and reducing the trees is unlikely to significantly reduce the Arboricultural or amenity value of the local area. Pruning is required to accommodate access to construct the proposed dwelling on Plot 1, and future pruning would be required to maintain. This would result in a repeated fiscal maintenance cost for the future occupiers of Plot 2.
- 9.1.18 There is likely to be a pressure to prune/ remove conflict between this tree and the occupiers of Plot 1 in the future when this tree reaches maturity. The current canopy spread of T14 Northeast is around 4.7m. The crown spread of Lime trees can reach up to 10m in maturity. Ideally there would be greater distance between Plot 1 and tree T14 to allow the canopy of the tree to grow unimpeded into maturity, without needing to prune for clearance from the dwelling and to lessen the likelihood of the future occupiers desiring to prune or remove the tree. It is recommended that gutter guards are installed on the dwelling to reduce the regularity of tree debris blocking the gutters.

9.1.19 Trees naturally drop leaves, twigs, seeds, sap, and small branches as part of their life cycles. This debris however can be nuisance to occupiers when trees are in close proximity to structures. This is due to the debris blocking guttering and falling on roofs, increasing the cleaning and maintenance costs. Some occupiers report that tree debris falling onto roofs results in increased moss growing on roof tiles, which over time, increases the likelihood of damp forming and leakages.

### Root Protection Area (RPA) encroachments

Table 3: Encroachments into Root Protection Areas (RPAs) by proposed hard surfacing

Tree	Category	RPA encroached by new proposed hard surfacing?	RPA encroached by new dropped kerb (likely resulting in root severing and removal)	RPA encroached by proposed foundations?	Total potential direct RPA encroachment:
T12	B	Yes = 9.2m <sup>2</sup> = 10% of Total RPA	Yes = 1.8m <sup>2</sup> = 2%	No	11m <sup>2</sup> = 12% of Total RPA
T13	B	Yes = 14.8m <sup>2</sup> = 10.8% of Total RPA	No	No	14.8m <sup>2</sup> = 10.8% of Total RPA
T14	A	Yes = 0.64m <sup>2</sup> = 0.5% of Total RPA	No	No	0.64m <sup>2</sup> = 0.5% of Total RPA
G4 (Southwestern tree)	B	Yes = 10.7m <sup>2</sup> = 26.1%	Yes = 0.5m <sup>2</sup> = 1.2%	No	11.2m <sup>2</sup> = 27.3% of Total RPA
G4 (middle tree)	B	Yes = 8.8m <sup>2</sup> = 21.5%	No	No	8.8m <sup>2</sup> = 21.5% of Total RPA
G4 (Northeastern tree)	B	Yes = 5.7m <sup>2</sup> = 13.9%	No	No	5.7m <sup>2</sup> = 13.9% of Total RPA

Note: The stem diameters of G4 were estimated as 300mm each, giving a total RPA of 41m<sup>2</sup> for each tree within G4

9.1.20 Trees in G4 and T12, T13 and T14 would have their RPAs encroached to varying extents by the proposed access road and pavement.

9.1.21 Excavation would not be acceptable for the construction of the expanded driveway and the removal and renovation of the existing area, as this would risk severing tree roots.

9.1.22 Therefore, a no-dig, permeable, load bearing, cellular confinement system will be required to construct the access road and pavement.

9.1.23 This is to prevent severing of tree roots and to minimise compaction of the soil within and around the trees RPA. Both of these can lead to tree decline and death, and hence this is important to mitigate the impacts of the access road and pavement.

9.1.24 An example is the Cellweb TRP system

9.1.25 A 'No-Dig Construction' ground protection system incorporates the following main components:

- A **geotextile separation layer (e.g. Treetex Geotextile)** laid onto top of the existing ground and top soil, separating the system above from the soil and rooting environment below.
- A **synthetic 3D cellular confinement grid (e.g. Cellweb TRP)** laid onto of the geotextile separation layer. This is a load spreading material that is designed as a grid/web to support driveways and roads by distributing load.
- The **3D synthetic cellular confinement grid (eg. Cellweb TRP)** infilled with a 4-20mm clean angular stone. The confined angular stone locks together to produce a rigid stone mattress, while maintaining air pockets for continuous water permeation and gas exchange. A **porous** surface can then be laid on top. A 'No-Dig Construction' ground protection system, **MUST** be permeable to allow water and oxygen to diffuse to the soil below. This includes having a porous surface. All surfaces in Root Protection Areas must be porous. Surfaces can include **porous block paving, porous asphalt, loose gravel, grass and gravel retention systems (e.g Golpla), and resin bound gravel.**

9.1.26

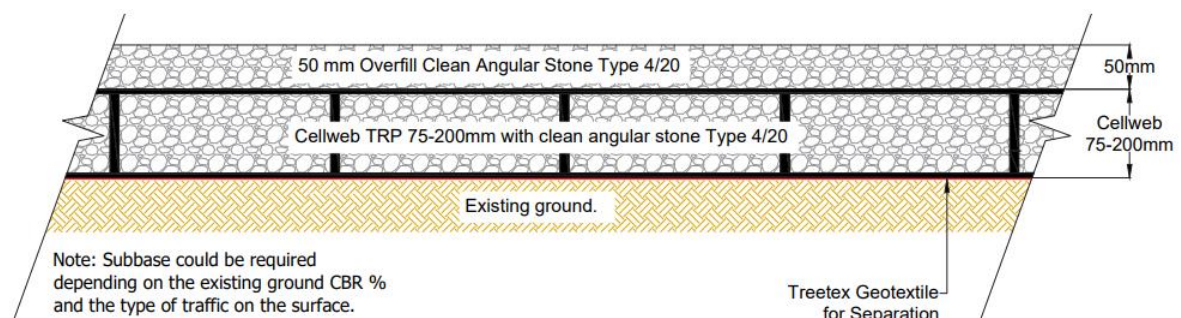

Figure 2: Indicative specification for Cellweb TRP No dig system for new hard surfacing within RPAs with a porous structure.

Table 4: Showing depths of Cellweb TRP for load requirements, from Geosynthetics Ltd.

Which depth of Cellweb®TRP do I need?

Depth of Cellweb®TRP	Unit	Gross Vehicle Weight (GVW)	Application
200 mm	Kg	< 60,000	HGV & Unusual - Crane / piling rig
200 mm	Kg	< 50,000	Heavy Construction Traffic
150-200 mm	Kg	< 30,000	Standard Construction Traffic & Refuse vehicle
150 mm	Kg	< 16,000	Emergency Access & Tractors
100-150 mm	Kg	< 9,000	Delivery Vans
100-150 mm	Kg	< 6,000	Car Park: Cars & Light van
100mm	Kg	< 3,000	Domestic Traffics: Cars
75mm	Kg	< 1,000	Pedestrians (with cyclist) path

9.1.27 The depth of the system is dependent on the load requirements. For heavy construction traffic entering the site, a 200mm depth would be required.

9.1.28 The total hard surfacing for all trees would be less than 30%. The Southwestern tree in G4 (Pine) would have the largest potential encroachment at around 27.3%. However, with the use of a cellular confinement system, which is porous and load bearing, the trees should be able to still access adequate oxygen and water through the system.

**New dropped kerbs**

9.1.29 Two sections of dropped kerbs would require excavating in order to remove existing payments to create the widened access way. These are within the RPAs of T12 and one tree within G4.

9.1.30 It is possible there could be tree roots of present underneath the pavement, and excavation to create a dropped kerb/ lower the pavement to match the road may result in severing of some of these tree roots.

9.1.31 The encroachments of these dropped kerbs into the RPAs is relatively minor:

- T12= 1.8m<sup>2</sup> = 2% of total RPA

And

- 0.5m<sup>2</sup> =1.2% of the Southwestern tree within G4.

9.1.32 If carried out sensitively using hand tools and with Arboricultural Supervision it is possible that root disturbance and severing can be minimised so as to not cause detrimental impact to the health and stability of the trees.

9.1.33 Any tree roots discovered shall be cut cleanly.

### **RPAs and foundations**

- 9.1.34 The proposed dwellings do not encroach directly into the RPAs of any trees.
- 9.1.35 The RPA of Tree T14 would be in close proximity, 0.4m, from the dwelling on Plot 1.
- 9.1.36 The RPA of the Northeast tree of G4 would be around 0.5m from the dwelling on Plot 2.
- 9.1.37 Some overspill encroachment may occur into these RPAs as a result of excavation for traditional strip footing foundation. This may result in root severing/ damage occurring.
- 9.1.38 Air excavation shall be used to excavate the section of foundations that are in close proximity to the RPAs of T14 and G4, to minimise overspill into these RPAs, that can occur through excavation using diggers. This will minimise excavation damage if there are roots in these areas.
- 9.1.39 This shall be overseen by an Arboriculturist. Any roots discovered shall be wrapped in damp hessian until they are re-covered with soil.

### **Soil Compaction within RPAs (Root Protection Areas) by construction traffic during development**

- 9.1.40 Soil compaction reduces pore spaces which are necessary for water and oxygen availability for tree roots. Construction traffic including foot traffic can reduce these pore spaces, which can reduce the health of trees.
- 9.1.41 Access would be required within the RPAs of T14 and G4, in order to excavate for the foundations and accommodate scaffolding.
- 9.1.42 Temporary ground protection is required in these areas. This will minimise compaction damage to the soil within RPAs, by spreading the loading of traffic on the soil.
- 9.1.43 The temporary ground protection will consist of ground protection boards (i.e. GroundGuards system) plus a depth of woodchip and a membrane (or similar).
- 9.1.44 Underneath the ground protection boards, a woodchip layer shall be laid. The woodchip shall act as a compressible layer, absorbing the loads on it by construction traffic, and spreading the weight, minimising compaction to the soil beneath. Below this, a membrane is laid. The membrane shall prevent the woodchip from being forced into the soil under loading, allowing it to remain as a compressible layer that will spread the load of Plant, machinery and pedestrians within RPAs

- 9.1.45 The expected weight & loading from plant, machinery and pedestrians needs to be confirmed at the pre-commencement meeting before development begins, to confirm the specifications for the temporary ground protection and depth of the woodchip to be used.
- 9.1.46 This information including the table below, is for the GroundGuards system and outlines the specifications to support the load requirements.



Figure 3: example of GroundGuards © temporary ground protection

Table 5: Credit to: <https://www.ground-guards.co.uk/wp-content/uploads/2022/01/Tree-Root-Protection-GroundGuards-White-Paper.pdf> : Ground Protection Practice Note GPPN8/21, Tree Root Protection using Temporary Access Trackways, By M J Oliver, Product Development Manager, GroundGuards

Traffic	Gross weight	Ground Protection Boards	Layers of boards	Compression layer	Membrane
Pedestrians only		GroundGuards MultiTrack	1	100mm woodchip	Geotextile
Pedestrian plant	Up to 2 t	GroundGuards MultiTrack	1	150mm woodchip	Geotextile
Vehicular plant	2 - 10 t	GroundGuards MultiTrack	2	150mm woodchip	Geotextile
Vehicular plant	10 - 20t	GroundGuards MaxiTrack	2	150mm woodchip	Geotextile
Vehicular plant	Over 20 t	GroundGuards XtremeMats	1	150mm woodchip	Geotextile

## Further Indirect conflicts and Impacts

### Preventing access within RPAs and preventing accidental mechanical damage to crowns of trees during Development

- 9.1.47 Construction machinery, plant and vehicles may cause physical damage to trees during construction. Such plant may also cause compaction to the rooting areas of trees in the surrounding areas. Compaction reduces pore spaces in the soil, suffocating tree roots, which can lead to root death and the decline of trees.

9.1.48 Tree Protection Fencing shall be installed to prevent access within the RPAs of retained trees. Protective fencing will be strong enough to withstand accidental strikes by machinery, plant or booms to prevent mechanical damage or compaction damage to trees to be retained. No materials or construction debris shall be stored within the protective fencing around the RPAs of any retained trees on site.

9.1.49 The areas within the Tree Protection fencing shall be known as the Construction Exclusion Zone. CEZ= Construction Exclusion Zone

9.1.50 Within The CEZ, the following is PROHIBITED:

- Access by pedestrians,
- Access by construction plant
- Access by vehicles
- Storage of construction materials
- Storage of Demolition Debris
- Construction Worker Parking
- Mixing, refuelling, spoil being tipped within it.

9.1.51 The type of tree protection fencing that shall be used is shown below:

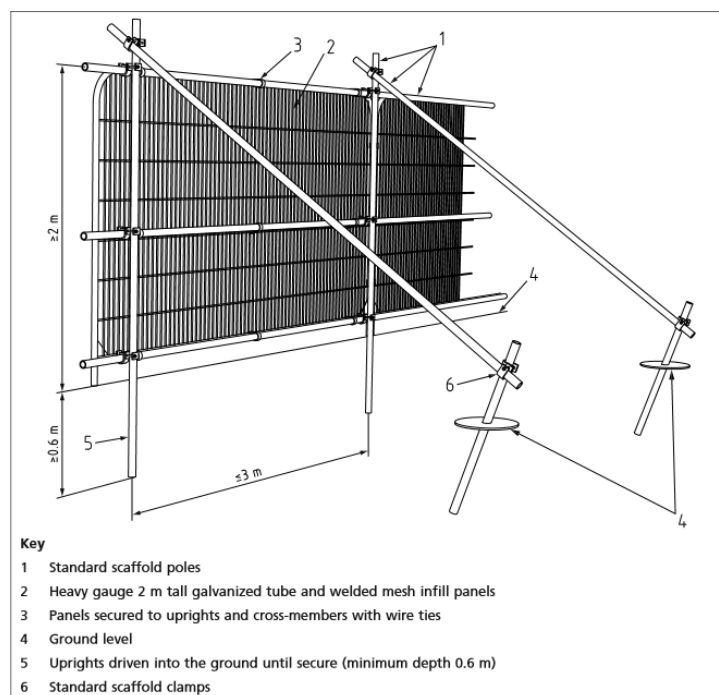

Figure 2- The type of protective fencing to be used is shown above taken from BS5837:2012 'Trees in relation to Design, Demolition and Construction- recommendations'



Figure 4- Tree Protection Signs attached to tree protection fencing

- 9.1.52 Fixed to the outside of the fencing will be words such as 'TREE PROTECTION AREA – NO ACCESS OR WORKING WITHIN THIS AREA'. These notices will be fixed to the fencing using suitable fixings such as tie wires and should be at least A3 in size and laminated.
- 9.1.53 Tree Protection fencing and temporary ground protection shall be installed before development commences and before any machinery or materials are brought onto site
- 9.1.54 These shall only be removed once development has been completed and all machinery and materials have been removed from the site.

#### **Storage of materials, car parking and welfare areas**

- 9.1.55 Construction worker parking shall be onsite, likely accessed via Church Street.
- 9.1.56 A welfare unit shall be located on site situated outside of all tree protection fencing.
- 9.1.57 Material storage shall be onsite, outside of tree protection fencing. Materials shall not be stored within RPAs on site.
- 9.1.58 Any skips shall likely be located towards the front of the site accessed via the existing access driveway from the south from Church Street.

### **Construction Access ways**

- 9.1.59 The existing access driveway from Church Street shall likely be used for the construction access way into the site until the new access way is constructed.
- 9.1.60 Materials shall not be stored within RPAs of any trees on site, unless as agreed by the project arboriculturist and LPA Tree Officer with suitable mitigation measures.

### **Potential Indirect Impact - Soil contamination within RPAs**

- 9.1.61 Spoil from mixing, fuel for machinery and other liquid contaminants could run, if spilt, into the RPAs of the trees. Such spoilage could affect the pH value, nutrient availability and other features in the soil in which roots grow, which can negatively affect the health of the trees.

### **Mitigation:**

- 9.1.62 Mixing will only take place in a designated area on the site. If refuelling of machinery and vehicles with fuel is required during development, this will either be carried out outside of the site or if machinery is on site, this will be carried out with the aid of absorbent material to prevent any spills from leaching into the soil.
- 9.1.63 Mixing will take place on tarpaulin or other impermeable sheeting/surface, to prevent any fuel spillage from leaching into the ground. Spill kits shall be present on site for all mixing, and for when concrete is delivered to the site.
- 9.1.64 Any spills of fuel, concrete mixing, spoil or other contaminants, on the soil, will be cleaned up immediately, using a spill kit.
- 9.1.65 Spoil will not be thrown away on-site; spoil will be thrown away into a skip.

### **New Landscaping**

- 9.1.66 It is recommended tree planting and soft landscaping is proposed on this site especially towards the frontage to promote the Arboricultural and amenity value of the site as viewed from Church Street and the surrounding areas.

## **Onsite consultation and Supervision**

9.1.67 An onsite meeting will be held with all relevant parties; including the developer, appointed Arboricultural supervisor and Local Planning Authority (LPA) representative to outline the methods of **construction**.

Report compiled by:

Rachel Selwyn

Signed.....  ..... Date 16 July 2025

*The following appendices give some further general information including tree categorisation, protective fencing and ground root protection for trees within RPAs*

## Appendix A- Tree Works Schedule

Table 6 Tree Work required to accommodate and facilitate proposed development

Tree	Category	Work required pre – commencement of proposal	Work required during development	Work required post development
G3	C2	Remove three trees within this group including stumps	N/A	N/A
H7	B2	Remove 9.5m and 34.7m of this hedge including stumps	N/A	None
H4	B2	Remove a 7m Section of this hedge including stumps	None	None
G4	B2	Tip reduction pruning on North/ Northwest side by up to 1.5m to accommodate scaffolding access.	None	None
T264	B1	None	None	None
T2	B2	None	None	None
T3	B2	None	None	
T4	C2	None	None	None
T5	C2	None	None	None
T6	U	None	None	None
T7	A1	None	None	None
T8	A1	None	None	None
T9	A2	None	None	None
T10	A1	None	None	None
T11	B2	None	None	None
T12	B2	None	None	None
T13	B2	None	None	None
T14	A2	None	None	None
G1	B2	None	None	None
G2	B2	None	None	None
H1	B2	None	None	None
H2	C2	None	None	None
H3	B2	None	None	None
H5	B2	None	None	None
H6	B2	None	None	None

## Appendix B- Arboricultural Survey information & Key

This report takes into account the findings from this visit. Quantitative data is provided on tree species, height, diameter, age class, crown spread, British Standard category, crown clearance, and a brief assessment of tree condition and future potential. Trees found to be structurally dangerous or in poor condition are identified.

The location of the trees with their calculated Root Protection Area (RPA) is shown in the tree constraints plan in the next chapter.

All data for each tree is presented in table format. The survey includes the information below:

### Tree Survey Table Key:

**Survey Reference number-** Trees were tagged.

**Species-** Species identification is based on visual observation with the common English name given first and the botanical name given in italics. If the species was not identified it is marked as Unidentified.

**Tree Heights** - These were measured in metres using laser technology. Where access was limited or there was little visibility due to overcrowding, heights were estimated.

**Stem no.** – Number of stems

**Ø (mm)= Stem diameter** measured at 1.5m above ground level - Measured using diameter tape in mm at 1.5m above ground level. In the case of grouped trees, the largest diameter was recorded.

**Stem Diameters** -

**Crown Spread** - The crown spread was measured in metres in the North, South, East, and West directions. Where access was limited crown spread was estimated.

**Crown Clearance** - the height of the first significant branch was measured. Where access or visibility is limited, this was estimated.

**Age class** - trees were recorded as young, semi-mature, early mature, mature, and over-mature as prescribed in BS 5837:2012.

**RP** - Root Protection

- **A (m<sup>2</sup>)**= Area
- **R (m)**= radius

**Condition** – tree condition was recorded particularly concerning structural and/or physiological conditions (eg. The presence of decay, physical defects, and/or preliminary management recommendations)

Where trees are grouped or in the case of woodlands, the condition stated will be typical of the feature. Groups of trees and woodlands are represented and the RPA will be included in the total area shown. The RPA will be calculated by taking an average measurement of stem diameter.

**Deadwood** -

Minor deadwood- less than 25mm in diameter

Moderate deadwood- 25-50mm in diameter

Major deadwood – Greater than 50mm in diameter

**P = Physiological condition**

**S = Structural Condition**

Those trees marked 'Good' can generally be classed as having good overall structural and physiological condition. They usually contribute significantly to the local or site amenity.

Those trees marked 'Fair' can generally be classed as having reasonable structural and physiological condition. They may contain smaller areas of included bark within either major or minor fork junctions. They may be subject to single or multiple fungal invasions, bacteria or viruses. They may be subject to minor crown dieback, unusually pale or smaller foliage or have been subjected to outside influences such as restriction of rooting spread, vandalism or mechanical damage, but should be viewed as in generally good overall condition.

Those trees marked 'Poor' can generally be classed as having poor overall structural or physiological condition. They may contain large areas of included bark either within major fork junctions. They may be subject to single or multiple fungal invasions, bacteria or viruses. They may contain splits or cracks throughout the branching structure. They may be subject to significant crown dieback or exhibit unusually pale or small foliage. They may be subject to outside influences such as restriction of rooting spread, vandalism or mechanical damage and are costly to retain.

**Estimated Remaining Contribution/ Life Expectancy** – estimated (eg. Less than 10 years, 10-20 years, 20 – 40 years, 40+ years).

## RPA

An RPA is a calculation which estimates the area of soil around a tree needed to ensure the survival of retained trees.

By considering the RPAs and existing site features (including natural and man-made topography) and by adopting construction and tree protection techniques that minimise root disturbance, successful construction projects can be achieved

### Root Protection Area (RPA) Calculations

All trees in retention categories A, B, C and U have their RPA calculated and the RPA figure given represents the radial distance, from the tree's trunk, at which barriers should be erected. The calculation for the RPA is as per section 4.6 of BS 5837:2012.

For single-stem trees, the RPA should be calculated as an area equivalent to a circle with a radius 12 times the stem diameter. For trees with more than one stem, one of the two calculation methods below should be used. In all cases, the stem diameter(s) should be measured in accordance with Annex C, and the RPA should be determined from Annex D. The calculated RPA for each tree should be capped at 707 m<sup>2</sup>.

- a) For trees with two to five stems, the combined stem diameter should be calculated as follows:

$$\sqrt{(\text{Stem diameter } 1)^2 + (\text{Stem diameter } 2)^2 \dots + (\text{Stem diameter } 5)^2}$$

- b) For trees with more than five stems (not illustrated in Annex C), the combined stem diameter should be calculated as follows:

$$\sqrt{(\text{mean stem diameter})^2 \times \text{number of stems}}$$

*N.B. Where all stem diameters were not accessible, this averaging formula has been adopted.*

The RPA for each tree should initially be plotted as a circle centred on the base of the stem. Modifications to the shape of the RPA should reflect a soundly based Arboricultural assessment of likely root distribution.

Any deviation in the RPA from the original circular plot should take account of the following factors whilst still providing adequate protection for the root system: a) the morphology and disposition of the roots, when influenced by past or existing site conditions (e.g. the presence of roads, structures and underground apparatus); b) topography and drainage; c) the soil type and structure; d) the likely tolerance of the tree to root disturbance or damage, based on factors such as species, age, condition and past management.

### Appendix C: Caveats and Limitations

This survey has been undertaken in compliance with BS5837:2012; it is not intended to be a tree safety survey. Tree inspection was carried out from ground level using the Visual Tree Assessment methodology. The survey did not include any climbing or investigation beyond what was visible from access points. Digital Scanning Software and other decay detection methods were not available to detect internal decay. No soil samples were taken. Any structural defects present may not be visible, for example being masked by vegetation, whether the tree's foliage, plants growing around the base of the tree, or climbing plants growing on the stem and into the crown.

This report includes an evaluation of the tree(s) on the day the site visits were made. Where access was limited, measurements were estimated. This report takes into account findings from these visits. Where similar trees are growing in large groups, their height and diameter may be estimated. Trees were surveyed if they affected the site and if their diameters at 1.5m exceeded 150mm in a woodland setting (75mm for individual trees).

This Arboricultural survey is valid only for typical weather conditions. Healthy trees, or parts of healthy trees, may fail at any time. Structural failures occur when the stresses due to the forces acting on a tree exceed the strength of the tree structure or the tree–soil connection supporting the tree. Even a structurally strong tree, free of defects, will fail when a load is applied that exceeds the load-carrying capacity of one or more of its parts. Most tree structural failures involve a combination of structural defects or conditions, such as the presence of decay or poor structure and an unusual or extreme loading event, such as strong wind. Every effort has been made to identify defects or hazards but no guarantee can be given for their safety. Healthy trees may fail in unusually high or unpredictable winds or violent storms and as the consequences of such weather phenomena are unforeseeable, Selwyn Trees cannot be held liable for any such failures.

Unless otherwise stated, the survey data should be considered time-limited for planning purposes to a maximum of 1 year.

Any legal descriptions stated or given by the consultant are understood to be accurate. Selwyn Trees will not assume responsibility for legal matters that arise from this survey, and will not be required to act as a legal witness to give testimony or attend court unless agreed arrangements are subsequently made.

Land managers are responsible for any work on surveyed trees or for carrying out any recommendations.

#### Appendix D: Author's Qualifications and experience

**Rachel Selwyn** BSc (Hons) Arboriculture and Urban Forestry, MArborA, QTRA registered.

Rachel is a consultant at Selwyn Trees and has 10 years of experience working in the role. She has a BSc Hons degree in Arboriculture & Urban Forestry from the University of Central Lancashire. She is a professional member of the Arboricultural Association and is a registered user of the Quantified Tree Risk Assessment methodology. Her work ranges from detailed tree assessment using specialist technology to producing a range of tree reports for development projects and providing tree protection solutions to BS5837 standards.

## Appendix D: British Standard BS 5837:2012 Table 1 Cascade chart for Tree Quality Assessment:

<b>Trees for Removal</b>			
<b>Category and definition</b>	<b>Criteria</b>		
<p><b>Category U</b> Those in such a condition that cannot realistically be retained as living trees in the context of the current land use for longer than 10 years</p>	<p>Trees that have a serious, irremediable, structural defect, such that their early loss is expected due to collapse, including those that will become unviable after removal or other U category trees (e.g where, for whatever reason, the loss of companion shelter cannot be mitigated by pruning)</p> <p>Trees that are dead or are showing signs of significant, immediate, and irreversible overall decline.</p> <p>Trees infected with pathogens of significance to the health and /or safety of other trees nearby, or very low quality trees suppressing adjacent trees of better quality.</p> <p><i>NOTE Category U trees can have existing or potential conservation value which it might be desirable to preserve</i></p>		
<b>Trees to be considered for retention</b>			
<b>Category and definition</b>	<b>Criteria- sub categories</b>		
	<b>1 Mainly Arboricultural Values</b>	<b>2 Mainly landscape values</b>	<b>3 Mainly Cultural values</b>
<p><b>Category A</b> Trees of high quality with an estimated remaining life expectancy of at least 40 years</p>	<p>Trees that are particularly good examples of their species, especially if rare or unusual, or those that area essential components of groups, or of formal or semi-formal Arboricultural features (e.g. the dominant and/ or principle trees within an avenue)</p>	<p>Trees, groups or woodlands of particular visual importance and /or landscape features</p>	<p>Trees, groups or woodlands of significant conservation, historical, commemorative or other value (eg. Veteran trees or woodland pasture)</p>
<p><b>Category B</b> Trees of moderate quality with an estimated remaining life contribution of at least 20 years</p>	<p>Trees that might be included in the high category but are downgraded because off impaired condition (e.g. presence of remedial defects including unsympathetic management and storm damage), such that they are unlikely to be beyond retention for beyond 40 years; or trees lacking the special quality necessary to merit the Category A designation</p>	<p>Trees present in numbers usually growing as groups or woodlands, such that they attract a higher collective rating than they might as individuals; or trees occurring as collectives but situated so as to make little visual contribution to the wider locality</p>	<p>Trees with material conservation or other cultural benefits</p>
<p><b>Category C</b> Those of low quality and value with an estimated remaining life expectancy of at least 10 years, or young trees with a stem diameter below 150mm</p>	<p>Unremarkable trees of very limited merit or such impaired condition that they do not qualify in higher categories</p>	<p>Trees present in groups or woodlands but without this conferring on them significantly greater landscape value, and/or trees offering low or only temporary screening benefit</p>	<p>Trees with no material conservation or other cultural benefits</p>

