

DO NOT SCALE THIS DRAWING. IF IN DOUBT ASK

NOTES AO

1. **EARTHWORKS:**  
 ALL EARTHWORKS ARE TO BE UNDERTAKEN IN ACCORDANCE WITH THE CURRENT EDITION OF THE DOT SPECIFICATION FOR HIGHWAY WORKS WITH CLARIFICATIONS SET OUT IN SECTION 020 OF THE ENGINEER'S SPECIFICATION AND AS SET OUT BELOW.  
 THE UPPER SURFACE OF THE SITE SHOULD BE STRIPPED OF ALL WEATHERED MATERIAL AND THE SPARSE VEGETATION ACROSS THE AREA AND A NOMINAL DEPTH OF 150mm SHOULD BE ALLOWED FOR.  
 EXPOSED FORMATION SHOULD BE ROLLED PRIOR TO THE PLACEMENT OF FILL OR SUB-BASE.  
 FILLING TO FORMATION USING SUITABLE EXCAVATED COLLIERY WASTE FROM CUT AREAS SHOULD BE COMPACTED IN LAYERS NOT EXCEEDING 200mm IN THICKNESS, INCLUDING ANY LOCALISED EMBANKMENTS AROUND THE PERIMETER OF THE HARDSTANDING.  
 EXCAVATED SPILL WILL GENERALLY BE DISPOSED OF ON SITE AS NOTED ON THE DRAWINGS.
2. **CONCRETE SURFACING:**  
 THE DESIGN OF THE SLAB, THE JOINTS AND THE REINFORCEMENT SHALL BE UNDERTAKEN BY THE SPECIALIST SUB-CONTRACTOR APPOINTED BY THE MAIN CONTRACTOR, SUBJECT TO THE MINIMUM REQUIREMENTS SET OUT BELOW.  
 (i) 200mm THICKNESS OF GRADE RC40 AIR-ENTRAINED CONCRETE OR EQUIVALENT.  
 (ii) A193 CENTRAL MESH REINFORCEMENT.  
 (iii) JOINTS GENERALLY TO BE DOWNLEGGED AND SEALED WITH AN APPROVED MATERIAL.  
 (iv) CONCRETE SURFACE TO HAVE A LIGHT BRUSHED FINISH WITH TROWELLED MANGING TO MATCH THE EXISTING CONCRETE HARDSTANDINGS ON SITE.  
 AN APPROVED CURING AGENT AND SURFACE HARDENER SHALL BE APPLIED AFTER CONCRETING AND FINISHING.  
 (v) 1200 GAUGE SLIP MEMBRANE WITH TAPED AND LAPPED JOINTS INSTALLED BELOW THE SLAB.  
 (vi) SUB-BASE TO BE DOT TYPE 1 COMPACTED MATERIAL BLINDED WITH FINES WITH 150mm THICKNESS.

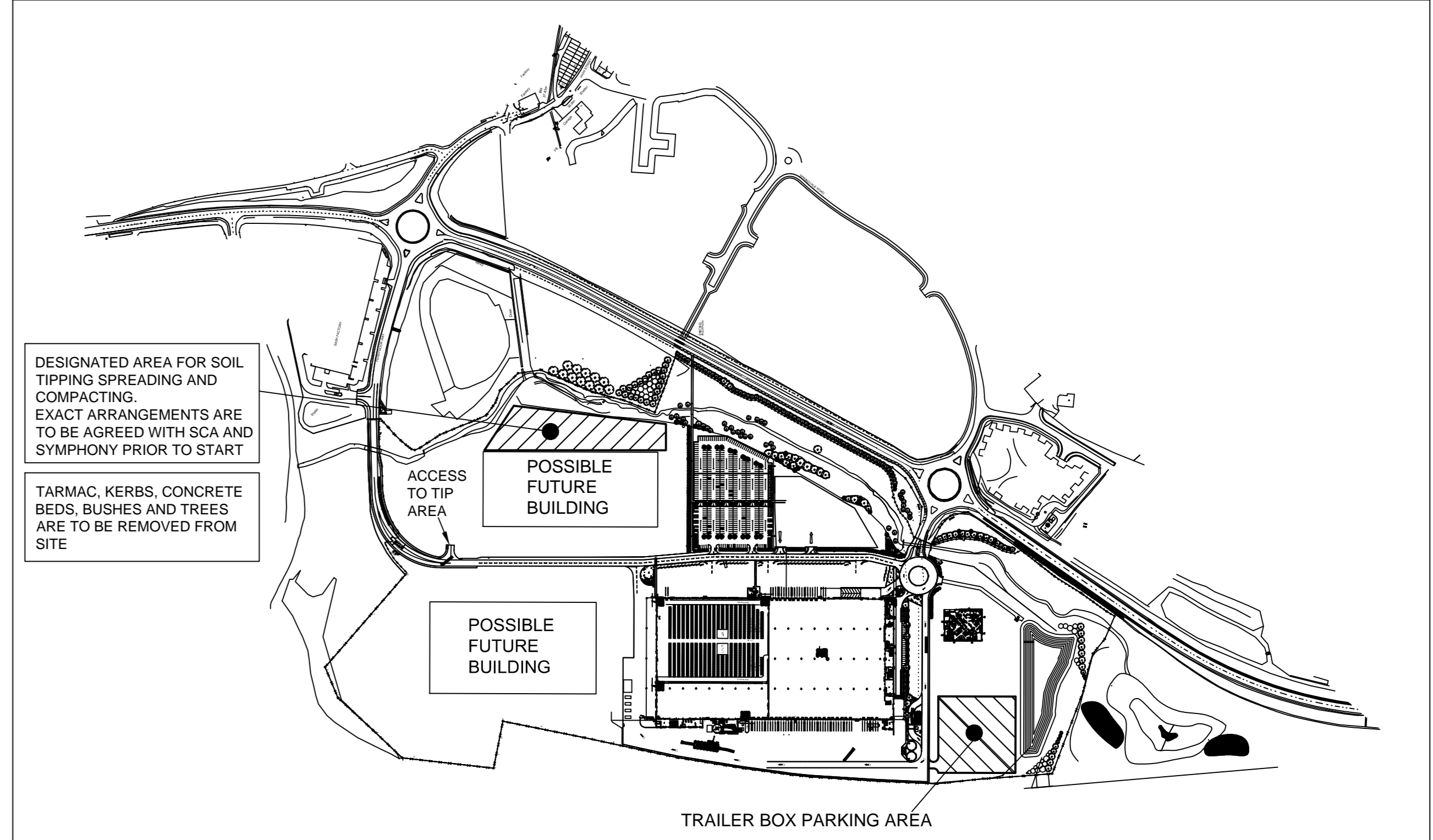
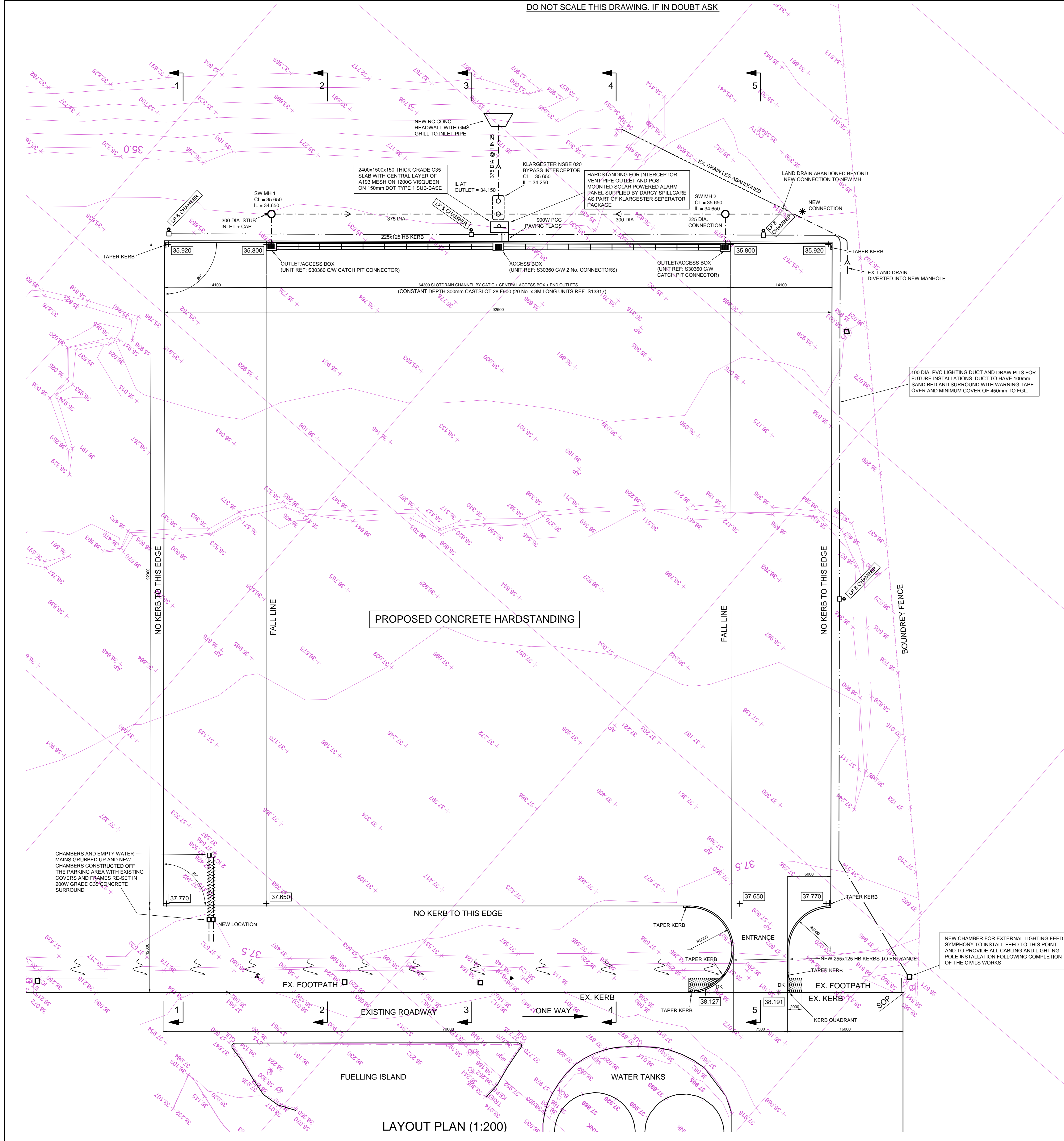

SITE LAYOUT PLAN (1:5000)

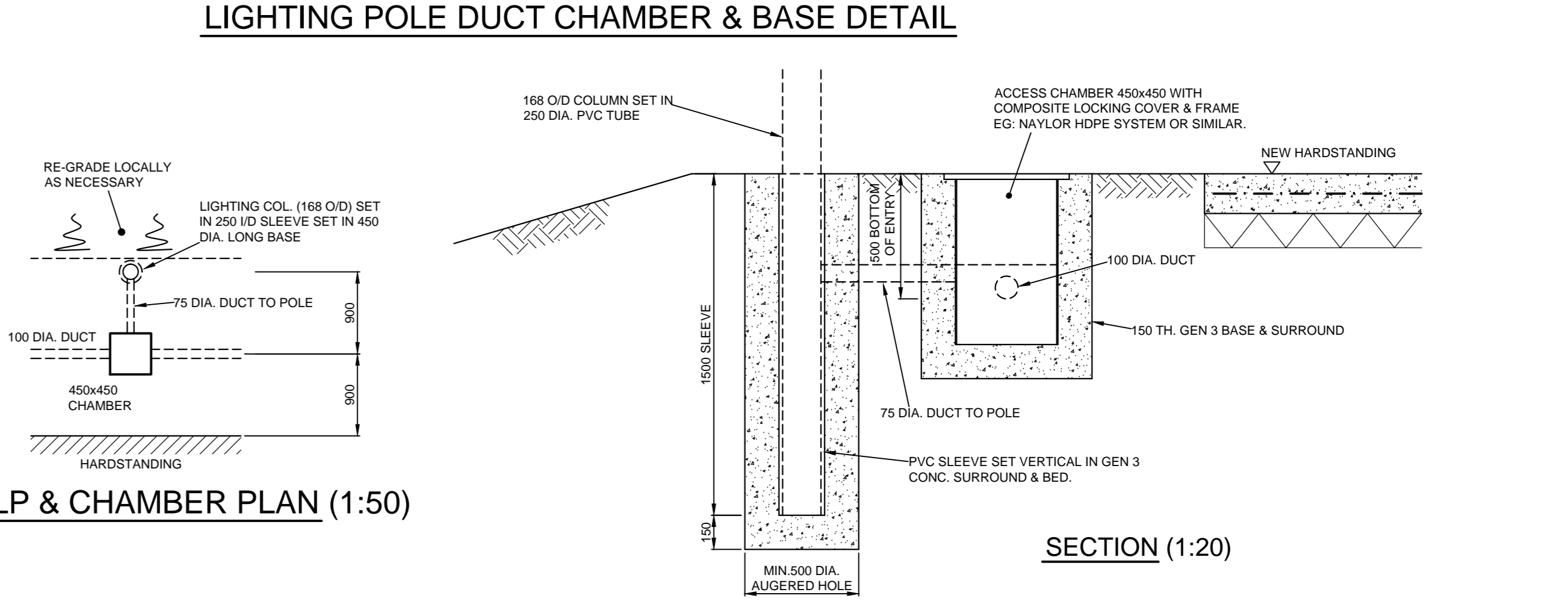

LIGHTING POLE DUCT CHAMBER & BASE DETAIL  
 LP & CHAMBER PLAN (1:50)  
 SECTION (1:20)

TENDER ISSUE

Rev	Description	By	App	Date
1	SYMPHONY GROUP, PARK SPRING ROAD, BARNESLEY ST2 7EZ. TRAILER BOX PARKING. PROPOSED LAYOUT PLAN.			

Stevenson Calam Associates  
 CONSULTING ENGINEERS  
 102 STATION PARADE  
 HARROGATE HG1 1HQ  
 Telephone (01423) 520069  
 Facsimile (01423) 520028  
 Email: stevenson.calam@bcconnect.com

SCA

Drawn	Checkd	Scale	Drawn No.	Revision
NC	MARCH 2015	1:200	1484-1/1	DGC

SEE DRAWING No. 1484-1/2 FOR SITE SECTIONS 1-1 TO 5-5