

Infocus Communication Hub

HUB DETAIL

The rise in mobile phone use has corresponded with the decline in the use of the traditional public payphone. The role of the public phone box also needs to adapt to modern life and the needs of the public to stay connected when out of home. The JCDecaux Hub unit redefines the role and function of the traditional payphone to a multipurpose communication Hub that provides the means for people to engage with each other and public bodies.

The Hub offers a range of services that include free ultrafast Wi-Fi, free phone calls to landlines and charities, defibrillator, wayfinding, device charging, rapid connection to emergency services, public messaging capabilities, and a platform for other technologies such as environmental conditions, CCTV and key data. These innovations are implemented against the backdrop of energy savings to comply with the climate emergency, with all units powered by green electricity and lit using high-capacity batteries, powered by solar energy.

Currently under development is voice activation, which will be particularly helpful for those with disabilities but also, in a post Covid 19 World, will ultimately enable calls to be made and browsers to be opened by voice command and without touching a screen or the use of a handset.



Each unit will stand at 2.6m in height and 1.3m wide, equal to the standard 6 sheet size unit, and occupy a site area of less than 0.50m<sup>2</sup>. The unit has undergone rigorous testing in extreme conditions and can boast 13.5mm thick antivandal toughened safety laminated glass on all glazed surfaces. The other external elements have been treated with a nanotech surface treatment to enable easy removal of stickers and/or sprayed paint to the external surfaces.

JCDecaux

# Communication Hub

## Digital 86" Smart City Unit



**IEMA** Transforming the world to sustainability

**IEMA Sustainability Impact Awards 2020**

Inspiration | Innovation | Transformation

**SHORTLISTED**



## Key Features

### Colour



An integrated touch screen designed for public phone use, and a range of other android compatible functions to enable users to access the internet and Council webpages and wayfinding around the City

The unit can also incorporate a range of sensors for the Smart City to monitor and report on environmental conditions and other key data

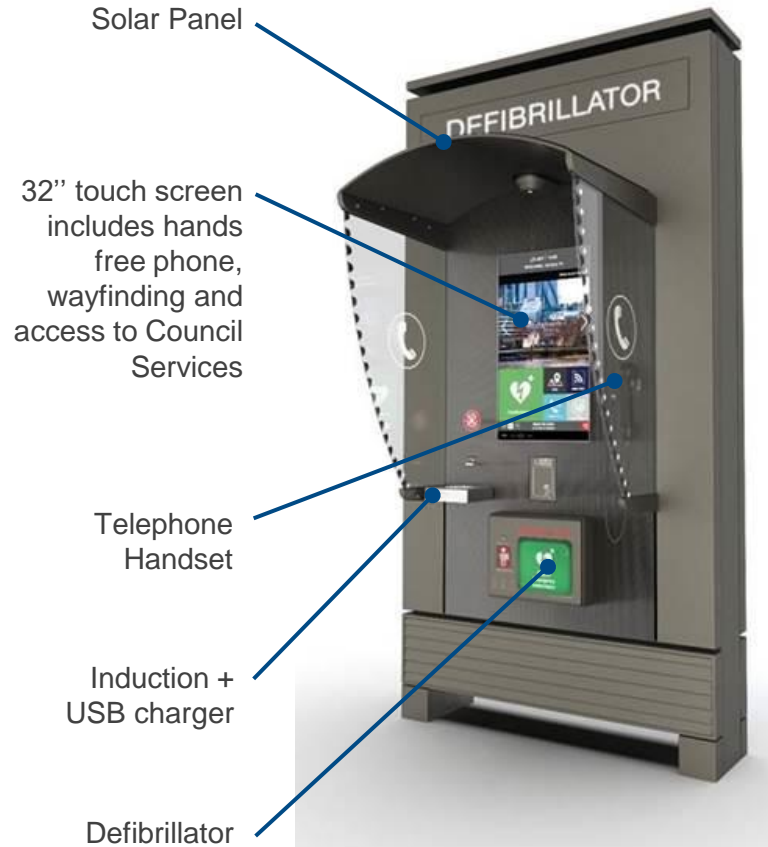

Front Façade  
Phone and Live Touch



Rear Façade  
Advertised Side

### INTERACTIVITY

Interactive touchscreen with localised services and applications



### PLACES

Location based services



### LIVE FEED

Events, news, transport and weather



### SOCIAL

City recommendations including cultural, retailing and on the best restaurants in the area



### TRANSPORT

Information including maps of the local area and beyond, bus timetables and transport and safety updates



### ENHANCING THE SMART CITY EXPERIENCE

- ◆ JCDecaux LiveTouch screens connect the city with residents and visitors providing localised updated and information
- ◆ The public can access a wide range of information about their area that included real time updates on transport, the latest news items, weather forecasts and other recommendations on places to visit
- ◆ The system runs on an android operating system, LiveTouch can support an unlimited number of applications making the possibilities endless

The unit will feature on one side an 86" screen and on the other a 32" touchscreen. The size of the screen is uniform and will be used for commercial and community messaging. When not in use the 32" screen will default to the City map to enable people to find their way around the City and shortcuts to the most often used apps and links to local services

## Use of the Hub Services

The Hub is intended as a free to use facility, however, in line with the advice of the Police Service, some units will have a more restricted use policy in known problem areas, whereby free calls will be prohibition other than emergency help lines. By applying more stringent controls in problem areas it is anticipated that the potential for these units to be misused will be minimalized or eliminated entirely.

Further management measures are also possible and are flexible enough to adapt to changing circumstances and on the advice of local Agencies The Company is committed to proper management of the service the Hub units provide and will constantly review and adopt best practice to design out the potential and opportunity for crime. The display screen on the reverse of the Hub unit is intended to be a platform for a range of messages, not solely commercial advertising. All screens will be available for public announcement, alerts, available helplines and provide a point where assistance is at hand.

# Communication Hub

## Managing Use



## Optional Functions and Sensory Parameters



Defibrillator



Climate: UV / Pressure / Temperature



Environment: Air Quality / Noise



Pedestrian Flow and Volume



NFC Static / Dynamic



Beacons



Wifi and Small Cell



Presence Detection



Voice Recognition \*



Collision Detection



Security Camera



Built in Speaker \*

\* Currently under development

## Operational Limits



### Operating conditions

Temperature: -15 to 45°C  
Humidity: 10% / 90%



### Digital screens

Technology : LCD  
Touch technology of the 32" Capacitive  
Aspect ratio 16:9  
Orientation Portrait

### 32" Specifications

Resolution Full HD (1920x1080 pixels)  
Light technology Edge LED  
Brightness Max 2000\* Cd/m<sup>2</sup>

### 86" Specifications

Resolution Ultra HD (3840x2160 pixels)  
Light technology Direct LED matrix  
Brightness Max 2000\* Cd/m<sup>2</sup>

\*Daytime limit level 2000Cd/m<sup>2</sup> and night time limit level 600Cd/m<sup>2</sup> as per ILP recommendations. Automatically adjustable according to ambient light.

### Dimensions

Visible area:  
• 86": 2,02m<sup>2</sup> (1065mm x 1895mm)  
• 32": 0.27m<sup>2</sup> (392mm x 698mm)

### Global:

• 1338mm (W) 2630mm (H) 317mm (D) (600mm canopy)



### Electricity

Input Voltage: AC 240 V 50/60hz  
Max Power: 3,94 kW  
Average consumption : 28,1 kWh/day (based on 24h/24 working hours)



### Connections

PC included  
Data: ADSL/4G/5G  
A secure solution to ensure full control of the content broadcast



### Certifications : CE



### Comments :

Selected best in class screens in term of visibility in full sunshine. It includes state-of-the-art features to lower TCO :

- Improved reliability and life through expert thermal and solar management design.
- Modular design.
- Replaceable external 4-4-2 (9.2mm) front glass
- Extensive monitoring capability through Digital Image verification that gives immediate feedback about display performance.

Premium product for reliability, monitoring and maintenance features



## Overview – Digital Screens

A payphone kiosk and interactive communication apparatus contained within a 32" display screen, which includes an outdoor advertising panel measuring 86". The Hub unit is designed and developed by JCDecaux

## Characteristics

Structural outer casing fixed to 2 structural legs clad with metal skirts.

- Touch Screen - An integrated space with metal housing set within the face of the unit.
- Display Screen - A 86 inch LCD screen housed behind a protected glazed face also forming an integral part of the unit.

The 86" screen features an Ultra HD resolution at 3840 x 2160 pixels displaying static contents that can be automatically and remotely changed. 32" touch screen features a Full HD resolution at 1920 x 1080 pixels.

The technology used to display the images screen is designed to be visible outdoor in direct sunlight. The unit also features an auto-dim function so adjust the screen luminance to harmonise with surroundings.

## Visible Area

LCD 16/9 Portrait screens

- 86": 2,02m<sup>2</sup> (1065mm x 1895mm)
- 32": 0,27m<sup>2</sup> (392mm x 698mm)

## Telecom Equipment and Touch Screen

Public Phone

Customized Council home page - an Android based application with an interactive screen for dialling numbers. Secure Android applications featuring location-based services. A touch pad is available under the screen to users with mobility impairment.

## Accessibility

Furniture easily acknowledged by blind and partially sighted pedestrians. Height of phone equipment from ground level enables access by wheel chair users. No sharp edges or profiles are present in the structures design.

## Pad touch 5,7"

Touch screen in compliance with accessibility standards thanks to the pad below the screen at 900mm from ground

## USB and wireless charger

Mobile phone charge points via USB and Qi wireless charging.

## Defibrillator

Automated External Defibrillator with optional theft protection, automated emergency service communication, remote monitoring and geo-locating.

## Solar panel

Solar panel on canopy roof.

# Communication Hub

## Technical Specification

### Foundation and groundwork

Furniture installed on to a concrete base with concealed fixing points.  
Separate underground ducting for power, data and earth protection via an earth mat.  
All calculated in relation to local requirements

### Standards and certification

CE certified and RoHS compliant.  
R&D and manufacturing to ISO 9001 and ISO 14001 standards.

### Reliability

Internal temperature maintenance control for both hot and cold seasons : ventilation is achieved via a filtered air cooling system that manages the internal temperature of the ad case and increases the life expectancy of components.

- Waterproof (power-hose from any angle)
- Dust resistant
- Rust resistant
- Sun fading resistance

Life expectancy is 5 years with normal usage (24/7) for the touchscreen and 10 years for the 86".

## **Environmental Considerations**

Automatic adjustment of the light intensity according to the location and the ambient light to rationalize as far as possible the energy required to operate the screen. Use of a powder coating without any Volatile Organic Compounds (VOC). Electrical and electronic equipment recycled according to WEEE regulations. Unit mainly manufactured from sustainable and recyclable materials

## **Brightness**

Maximum daytime brightness level 2000Cd/m<sup>2</sup>, night time maximum is 600Cd/m<sup>2</sup> as per ILP recommendations. Excellent visibility in all conditions, even under direct sunlight. Brightness levels to respond and adjust to ambient lighting :

- No glare risk
- Minimizing power consumption

## **Digital Management Software**

### *Web Interface*

Management of the display from a specific software platform available on any computer connected to the internet with access rights. Panels are collectively or individually programmable in advance.

Intuitive, efficient and easy to use programming interface developed by JCDecaux. Automatic update with no need for human intervention on the computer workstations.

# Communication Hub

## Technical Specification

## **Contents Scheduling**

Creation of messages and message loops  
Setting of the duration and order of messages  
Instant transmission between messages being entered and being received by the panel  
Consultation in real time of broadcast messages  
Possibility of broadcasting a loop to all the panels, to a group of panels or to individual panels

## **Contents Storage**

Periodic local update and storage of the contents (128Gb capacity) to feed the display loop avoiding any rupture of the broadcast in case of connection failure  
Display of a neutral message in case of dysfunction

Material	Treatment against corrosion	Defined	Main parts
Steel	Hot dipped galvanizing Centrifugal galvanizing		Foot structure Anchoring rods
Stainless Steel	Passivation		Screwing
Alluminium	Chromate conversion*	80µm powder paint	Casing – Door – Skirts
Tempered glass 6mm		Silk Screen Printing	32" screen glass
Laminated glass 4-4-2 (9.2mm)		Silk Screen Printing Anti-glare treatment	86" screen glass
Concrete			Foundation

\* Environmentally friendly treatment free from hexavalent chromium

### Resistance to Vandalism

- Skirts with smooth surfaces for easy cleaning and removal of any illegal stickers
- Protection rating against impacts > IK10 (corresponding to a 2-kg mass dropped from a height of one metre)
- Front face made of a patterned stainless steel non-scratch material
- Electrical circuitry inaccessible to the public
- 86" screen protected by a front face in 4-4-2 (9.2mm) thick anti-vandalism hardened laminated glass
- Secured casing opening for access to the PC and other equipment by a double locking system (Special keys plus Van Lock).
- No exposed screws
- Unit made from non-flammable materials
- All painted metal surfaces are coated with a high performance paint that is highly resistant to graffiti cleaning products
- Data transfers are protected by Firewall and password

### Remote monitoring

Unit fitted with sensors to check its operating status at all times.  
Errors are sent automatically over the network to the monitoring centre in the event of a malfunction

### Data Transmission

Set of secure connections:

- from the transmitter to the data server by means of a broadband link
- from the data server to the different communication devices by an ADSL or fiber link with a 3G/4G/5G backup

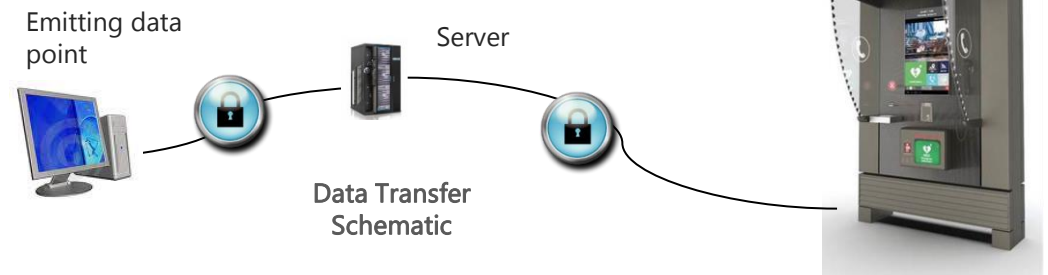

## Unit Elevations

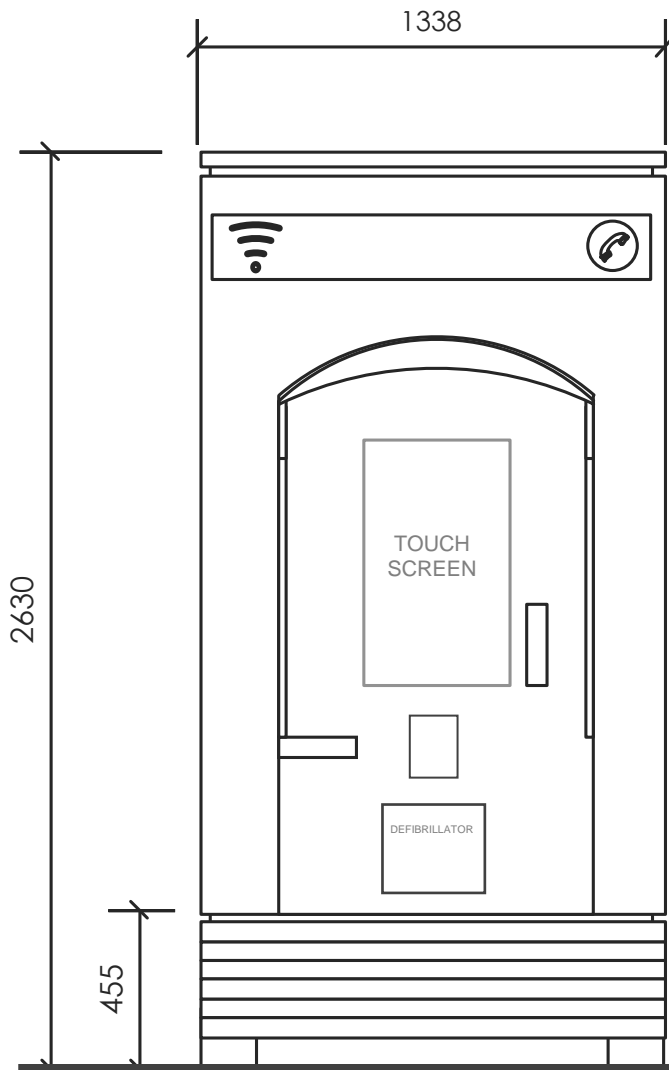

Unit Front

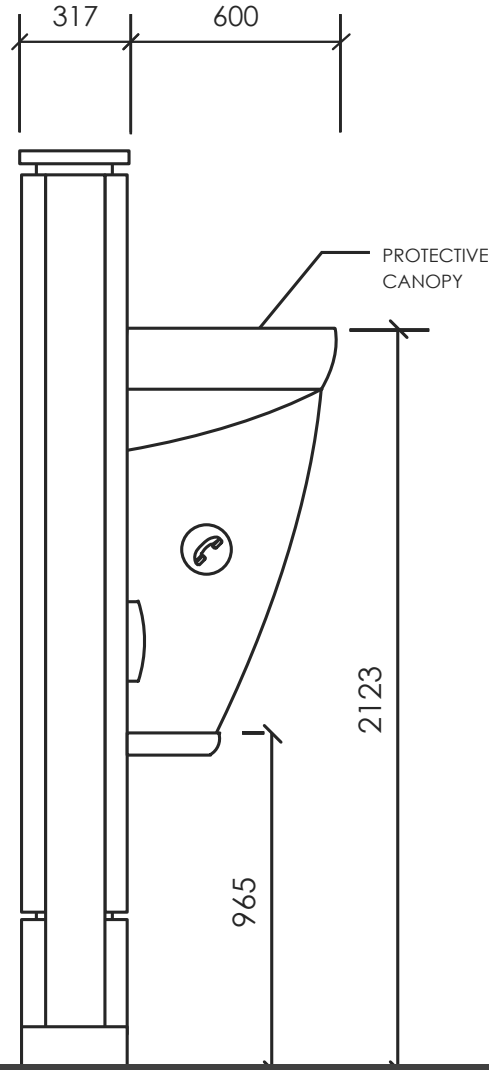

Side

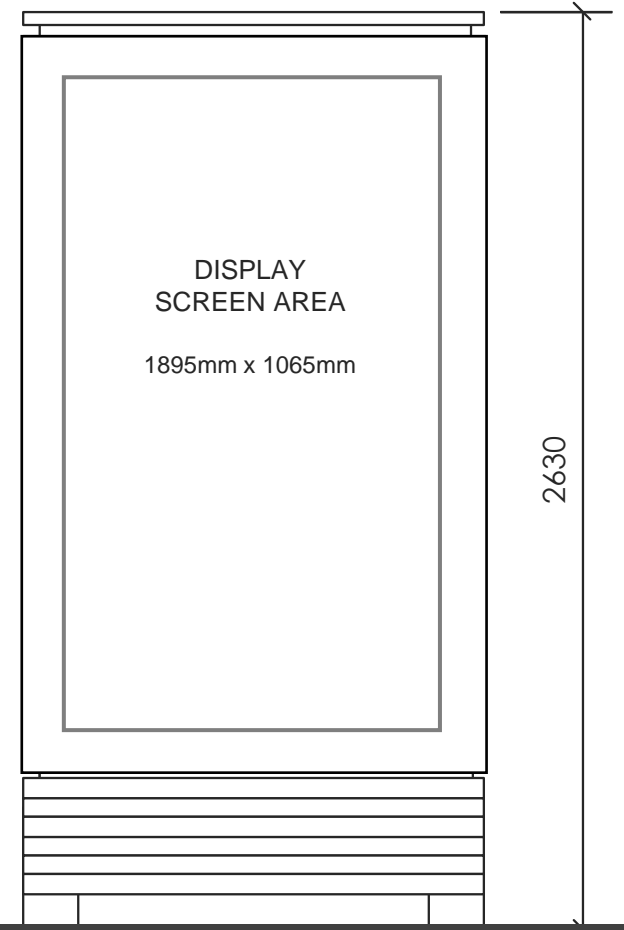

Unit Rear

JCDecaux

# Communication Hub

## Visual Imagery

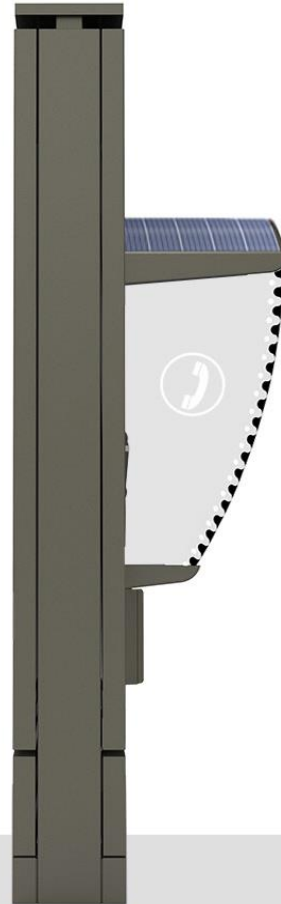
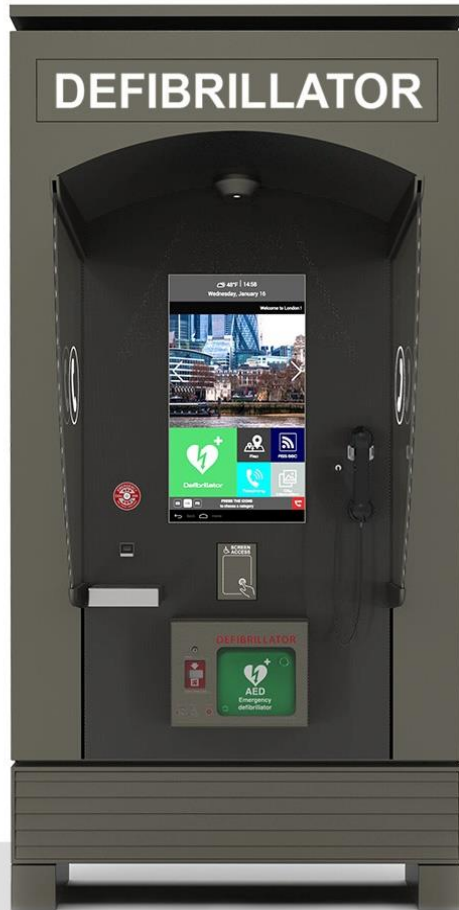

JCDecaux

# Communication Hub

## Installed Units





JCDecaux

# Communication Hub

## Installed Units

