

300 mm
200
100
50
10 mm
0

Refuse vehicle reversing into bin storage area.

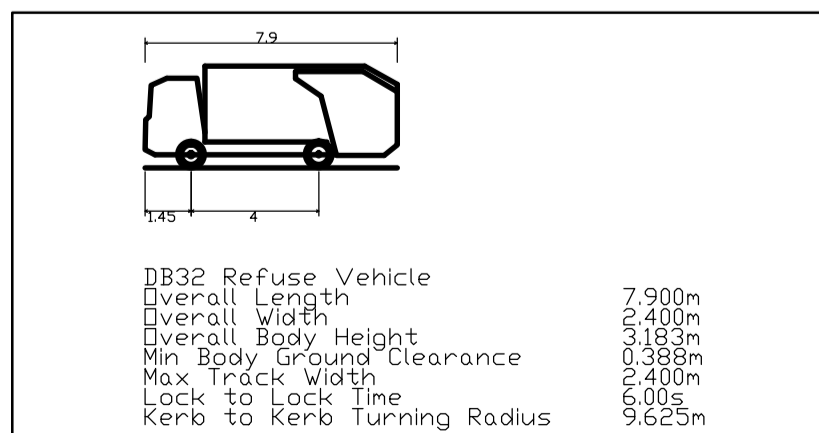

Revision	Amendment	Approved	Revision Date
R1	Updated Architects Plan	M.C	28/11/2014



Designed	Approved	Approved Date
S.Riddell	M.Cleggett	21/01/2015
Drawn	Scales	
S.Riddell	1:400 [A3]	

Project		Sheet No.	Revision
knight Frank LLP Mixed Use Scheme, The Kendray Birk Avenue, Barnsley		05	R1
Sheet			
Geometric Accessibility Swept Path Analysis			
Project No.			
J-B0746/05			

1:1 @ A1
1:2 @ A3
0 10 20 30 40 50 60 70 80 90 100 mm